



**WINDSOR
UTILITIES
COMMISSION**

**WINDSOR UTILITIES COMMISSION
WATER DIVISION
CITY OF WINDSOR**

DESIGN GUIDELINES AND SPECIFICATIONS

FOR

**WATER MAIN AND WATER SERVICE
INSTALLATION**

DECEMBER 2024



**WINDSOR
UTILITIES
COMMISSION**

**WINDSOR UTILITIES COMMISSION
WATER DIVISION
CITY OF WINDSOR**

**DESIGN GUIDELINES AND SPECIFICATIONS
FOR
THE INSTALLATION OF
WATER MAINS AND SERVICES**

Part 10	General
Part 20	Design Guidelines
Part 30	Specifications for Installation
Part 40	Approved Material Listings
Part 50	Standard Drawings

**REVISIONS TO BE NOTED ON THE TITLE PAGE OF EACH
SECTION**



WINDSOR
UTILITIES
COMMISSION

**WINDSOR UTILITIES COMMISSION
WATER DIVISION
CITY OF WINDSOR**

**DESIGN GUIDELINES AND SPECIFICATIONS
FOR
THE INSTALLATION OF WATER MAINS AND
SERVICES**

**PART 10
GENERAL**

Revisions

January 2015 – Revised Part 10
November 2015 – Revised Part 10
May 2019 – Added 10.04.02 NSF Compliance



10.01 GENERAL

10.01.01 INTRODUCTION

Many engineering consultants and construction contractors work within the City of Windsor and surrounding areas. One of the common industry comments was that the design guidelines and contract specifications differ among the various area municipalities. As such, the Specification Review Committee and Material Approval Committee were established to develop, review, and update the design guidelines and specifications for water main and water service installation for the Windsor Utilities Commission (WUC).

10.01.02 SCOPE

The purpose and benefit of creating a set of design guidelines and contract specifications are to facilitate the design and construction of water mains and services by consultants and contractors who work in more than one municipality.

Although this document is often referred to as specifications, the design portion (Part 20) should be considered as guidelines. This document provides the Windsor Utilities Commission's design preferences under normal circumstances. The Engineer however, should use their best judgment to find innovative solutions when abnormal design conditions are encountered. The Director, Water Engineering, must approve any design modifications made by the Engineer outside of this document.

10.01.03 MUNICIPAL SERVICES CONSIDERED

The municipal services currently considered are:

- Water mains and water services

For all other municipal services, the user must refer to the City of Windsor specifications. The water design guidelines and specifications apply to distribution of water only and do not apply to supply and/or treatment of water. Feeder mains may use additional special specifications.

10.02 DEFINITIONS

City Of Windsor: Refers to the municipality having jurisdiction over the works.

Enwin Utilities: The Operating Authority who is in charge of all public water mains and services in the City of Windsor, who supplies and distributes water to all customers in the City of Windsor.

Owner: Means the Windsor Utilities Commission, Water Division.

VP Operations: Responsible for all WUC operations.

Director, Water Engineering: That individual within the Windsor Utilities Commission having responsibility for the specification of design, construction and materials. All approvals, design alterations or other instructions must be issued in writing by the Director, Water Engineering or their authorized designate, before being considered valid.



Supervisor, Water Construction: The individual within the Windsor Utilities Commission who is in charge of all inspection work related to water mains and services.

Engineer: An individual licensed by the Professional Engineers of Ontario (PEO) who is responsible for the design of the works. May also be referred to as the Design Engineer.

Consultant: An individual Engineer or Consulting Engineering firm licensed by the Professional Engineers of Ontario (PEO) and retained by, or on behalf of the Developer or WUC.

Inspector:

The agent appointed or approved by the Director, Water Engineering to assist in the inspection of all material and labour. The Inspector will keep the Construction Supervisor informed as to progress of the work and the manner in which it is being done. The Inspector has authority to reject defective and improper materials and to suspend any work that is being improperly done, all in accordance with these standards, subject to the final decision of the Director, Water Engineering.

Developer: The owner of land upon which water services will be located. (Ultimately a part may be owned by the Municipality).

Contractor: The individual or firm responsible for the construction of the water main works.

Substantial Completion: This can be either the Initiation of the Maintenance Guarantee Period for subdivision servicing or the Substantial Completion of the Contract for other work. This is typically when the WUC assumes ownership of the works, subject to the warranty period.

Warranty Period: During this period of time, the Contractor is responsible for all costs related to repairing any defects in materials or workmanship. WUC will specify the length of the warranty period.

Water Distribution Report: This report is prepared by the designer to document the analysis completed to determine the layout and sizing of a water main or water distribution system.

10.03 DOCUMENT

10.03.01 DOCUMENT STRUCTURE

The document is structured in the following manner:

- Part 10: General
- Part 20: Design Guidelines
- Part 30: Specifications for Installation of Water mains and Services
- Part 40: Approved Materials Listings
- Part 50: Standard Drawings

10.03.02 IMPLEMENTATION

The Windsor Utilities Design Guidelines and Specifications for Water Mains and Services is a stand alone document (i.e. not bound into contract documents), that will be referenced in engineering agreements and contract documents. The Windsor Utilities



Commission however, may issue specific instructions or modifications to the specifications as part of a Special Conditions or Special Provisions section within construction contracts. Similarly, modifications may also be made to address project specific requirements; however, the Windsor Utilities Commission, under whose jurisdiction the work is undertaken, must agree to any such modifications.

Check with the Windsor Utilities Commission for additional standards or requirements. These specifications will be used on all municipal water mains and service additions and alterations including:

- Subdivisions
- Site Plans (Condominiums / Commercial / Industrial Lands)
- Reconstruction
- Improvements and augmentations
- Operations and maintenance

10.03.03 PRECEDENCE OF STANDARDS

The WUC Design Guidelines and Specifications are supplemental to the City of Windsor Specifications, Ontario Provincial Standards (OPS) and Ministry of Environment (MOE) Guidelines, thus taking precedence over the related specifications.

10.03.04 ONTARIO BUILDING CODE AND NFPA CODES

The WUC Guidelines and Specifications apply to municipally owned water mains and services. The installation of privately held services is governed by the Ontario Building Code, NFPA codes, City of Windsor Specifications and associated specifications which may include WUC Design Guidelines and Specifications. Where the OBC or NFPA are silent, WUC specifications govern.

10.03.05 AVAILABILITY OF SPECIFICATIONS

The current specifications are available free of charge via the Windsor Utilities Commission's website.

10.03.06 UPDATES / NOTIFICATIONS

On a regular basis, the Specification Review Committee and Material Approval Committee will review the specifications in light of comments received and the introduction of new materials and procedures. For manufacturers and suppliers who wish to have their products reviewed, please contact The Director, Water Engineering.

Comments are encouraged and may be forwarded to:

Chris Manzoni P. Eng.

Director, Water Engineering

Enwin Utilities

4545 Rhodes Dr. P.O. Box 1625, Stn. "A" Windsor ON N9A 5T7

Tel: (519) 251-7300 x295

Fax: (519) 251-7316

email: cmanzon@enwin.com



10.04 ENVIRONMENT

10.04.01 GENERAL

It is the aim of WUC to be environmentally responsible during all phases of the design, construction and operation of all water mains and services. The users of these guidelines and specifications must be familiar with the environmental protection standards by the various area municipalities, federal and provincial legislation.

10.04.02 NSF COMPLIANCE

All approved materials in The WUC Guidelines and Specifications shall conform to NSF/ANSI 61 and 372 where applicable.



WINDSOR
UTILITIES
COMMISSION

**WINDSOR UTILITIES COMMISSION
WATER DIVISION
CITY OF WINDSOR**

**DESIGN GUIDELINES AND SPECIFICATIONS
FOR
THE INSTALLATION OF WATER MAINS AND
SERVICES**

**PART 20
DESIGN GUIDELINES**

Revisions

April 2017 – Revised 20.05
October 2018 – Revised 20.04.04
May 2019 – Revised 20.05.02
November 2022 – Revised 20.05.01, 20.05.03, 20.05.08, 20.05.09
20.07, 20.02.08, 20.02
December 2023 – Revised 20.05, 20.05.01, 20.05.02, 20.05.03, 20.05.08
December 2024 - Revised 20.03.03



DESIGN GUIDELINES TABLE OF CONTENTS

20.01	INTRODUCTION	1
20.01.01	Geotechnical Investigation	1
20.01.02	General Specifications	2
20.02	WATERMAINS - GENERAL	2
20.02.01	Sizing	2
20.02.02	Classification	3
20.02.03	Water Demands	3
20.02.04	Locations	4
20.02.05	Depth	4
20.02.06	Crossings	4
20.02.07	Dead-End Mains	5
20.02.08	Abandonments	5
20.02.09	Easements	5
20.02.10	Casings	6
20.02.11	Construction In Fill Areas	6
20.03	MAIN LINE VALVES	6
20.03.01	Sizing	6
20.03.02	Number and Location	6
20.03.03	Valve Boxes	7
20.03.04	Valve Box Protection	7
20.04	HYDRANTS	7
20.04.01	Spacing	7
20.04.02	Branch Valve and Boxes	8
20.04.03	Locations	8
20.04.04	Depth of Bury	8
20.04.05	Air Valves	9
20.05	WATER SERVICES	9
20.05.01	Service Sizing	9
20.05.02	Service Location	10
20.05.03	Service Abandonments	10
20.05.04	Depth	11
20.05.05	Restraints	11
20.05.06	Mainstops	11
20.05.07	Curb Stops and Boxes	11
20.05.08	Metering	11
20.05.09	Backflow Prevention	12
20.05.10	Electrical Grounding	12
20.06	CONNECTION PROTOCOL	12
20.07	CORROSION PROTECTION	13



DESIGN GUIDELINES

20.01 INTRODUCTION

The design of municipal services in the City of Windsor is to be based upon the current WUC Design Guidelines and Specifications for Water Main and Water Service Installation. All plans are to be reviewed and approved by the WUC prior to the construction of services. Such review shall not relieve the engineer from primary responsibility for the design to meet all Federal, Provincial, and Municipal requirements.

Where watermains are to be used for fire protection purposes on private property they must satisfy the requirements of the Underwriters Laboratories of Canada in addition to the City of Windsor plumbing department, Ontario Building Code, and WUC Design guidelines and Specifications. Where these conflict, clarification is to be received from the Water Engineering Department.

The WUC strives to maintain a minimum operating pressure of 40 psi and a maximum operating pressure of 80 psi. Under no circumstance shall the minimal residual pressure be less than 140kPa (20 psi) at any location in the water distribution system.

20.01.01 GEOTECHNICAL INVESTIGATION

The consultant shall determine the need for soils investigation. However, if Water Engineering requests a soils investigation and analysis, the Consultant is obligated to supply one. Water Engineering may also request a Soil Characterization Report per O. Reg 406/19 at the sole expense of the developer.

The purpose of an investigation would be to determine the soil's composition, bearing strength, and type, and to verify that no contamination is present; which would be determined by the consultant. The consultant shall recommend the appropriate bedding requirements based on the findings of the Geotechnical Investigation and state them on the drawings.

Boreholes shall be taken to a minimum depth of one (1) metre below the anticipated depth of the watermain invert or the deepest utility.



20.01.02 GENERAL SPECIFICATIONS

All water distribution system components and lubricants are to be as stated on the WUC's list of approved products for watermains and must meet applicable AWWA Standards, NSF/ANSI 60 and 61 Standards, or other appropriate standards for approved materials, coatings or linings for distribution system components or chemicals that come into contact with potable water.

20.02 WATERMAINS – GENERAL

Where non-metallic pipe (e.g., PVC, concrete pressure pipe) is installed, a 12 gauge AWG copper clad steel, blue coloured HDPE coated tracer wire must be installed with and along the pipe and brought to the surface at each hydrant. Tracer wire to be attached to an approved access box and secured to the hydrant flange. See Standard Drawing 50.04.01 and 50.04.02.

All fittings shall be restrained per Standard Drawing 50.06.01.

An anode shall be installed on all metallic fittings and valves. Zinc anode caps to be installed on all bolts and nuts.

20.02.01 SIZING

Sizing and looping of watermains will be discussed at the preliminary stage of the project. For major projects, consult with the WUC's current hydraulic model. The following are the minimum pipe sizes required. Unless otherwise required, all watermains within the right-of-way shall be designed for 1,000 kPa (150 psi) test pressure.

250mm diameter is no longer considered a standard size in R.O.W.. A 300mm diameter watermain shall be used in lieu of any 250mm diameter watermain.



Residential Areas

- 150mm minimum diameter for mainlines; 50mm diameter will be allowed in cul-de-sac bulbs after the last hydrant right before the cul-de-sac.
- 300mm minimum diameter mainline servicing high density residential areas.

Commercial/Industrial Areas

- 300mm minimum diameter for mainlines.

20.02.02 CLASSIFICATION

Transmission Mains

Larger diameter pipes dedicated to transfer water between pressure zones, from downstream pumping stations to upstream reservoirs. These should be routed as determined through the Environmental Assessment process.

Feeder mains

Large diameter pipes greater than 400mm used to distribute water throughout the city.

Distribution Mains

Pipes 400mm and smaller, used to supply the majority of the connections to customers.

See 20.06 for connection protocol.

20.02.03 WATER DEMANDS

Water demands are to be calculated by the Design Engineer. Custom demands for larger volume consumers or those with exceptional peak demands like ICI (Industrial, Commercial, and Institutional) projects require special considerations regarding flow calculations.

For projects that require fire protection; the fire flow requirements shall be determined in accordance with the current issue of “Water Supply for Public Fire Protection”, Fire Underwriters Survey. A fire flow test will be required by the developer on hydrants surrounding the project to determine if adequate water is available.



20.02.04 LOCATIONS

Watermains shall be located in accordance with the local municipality's standard locations. A minimum horizontal separation of 2.5m (edge to edge) and a minimum vertical separation of 0.5m (bottom of pipe to top of pipe) if sewers are above the watermain and 0.15m (bottom of pipe to top of pipe) if sewers are below the watermain as per MECP design criteria. For watermain crossing a sanitary sewer, watermain joints are to be offset a minimum of 2.5m horizontally from the centerline of the sanitary sewer. See Standard Drawing 50.01.03. All non-standard watermain locations will require individual approval from the Director of Engineering. Any joint deflection shall be 50 percent of the manufacturer's specifications. Pipe barrel deflection is prohibited when using PVC pipe.

20.02.05 DEPTH

Paved Roads

The top of the watermain shall be constructed a minimum of 1.5m below the finished grade.

Open Ditch and Unpaved Roads

The minimum cover over the top of watermains shall be 2.1m below the existing centerline of the road, or 1.5m below the bottom of the ditch or 1.5m below grade if there is no ditch, whichever is greater. Where watermains within a ditch are crossed by driveways, the minimum depth of 1.5m shall apply.

Where the above mentioned requirements cannot be satisfied, refer to Standard Drawing 50.01.02 for insulation requirements.

20.02.06 CROSSINGS

Where watermains cross under a creek, the minimum cover over the watermain below the creek bottom shall be as per Conservation Authorities (ERCA) requirements but no less than 1 meter.



20.02.07 DEAD-END MAINS

Dead-end watermains are to be avoided wherever possible. Where dead-ends cannot be avoided, the maximum length of a permanent watermain is 200m unless reducing the watermain down to 50mm after the last hydrant to service the remaining lots up to an additional 50m from the hydrant. Where there is a cul-de-sac the watermain will reduce to 50mm after the hydrant just before the cul-de-sac.

20.02.08 ABANDONMENTS

Watermains to be abandoned shall be capped or removed as decided by Water Engineering. Abandonments of watermains larger than 300mm shall be filled with grout per Water Engineering instructions.

20.02.09 EASEMENTS

The minimum easement width shall be:

- 4.5m wide for all watermains up to and including 400mm
- 6.0m wide for all watermains greater than 400mm

Easements may be wider based on watermain depth. The width of an easement is to be decided by Director, Water Engineering.

The Engineer shall also consider the soil conditions, constructability and future maintenance when selecting the easement width. In addition, if more than one utility is installed in the easement, the easement width should be increased by the separation distance of the utilities.

WUC will need unencumbered access to the watermain easement. No permanent structures like sheds, swimming pools or trees exclusive of driveways shall be placed on the lands granted for easements. The WUC shall not be responsible for restoration or replacement of any structure located on easements, except for driveways.



20.02.10 CASINGS

When installing watermains within steel casings, the following shall apply:

- All casing spacers are to be per Approved Material Listing 40.26.02;
- Positioning of spacers along the watermain is to be as per the manufacturer's specifications;
- Position of pipe within the casing to be centered;
- The watermain shall be restrained laterally for the entire length of the casing;
- Casing to be sealed as per Approved Material Listing 40.26.03.

20.02.11 CONSTRUCTION IN FILL AREAS

The following notes are to be included on all drawings where watermain construction will take place in fill:

"No watermain shall be laid on fill until the density test reports have been submitted to and approved by the consultant or WUC. Fill shall be placed to 0.6m minimum above the top of the watermain grades and compacted to the minimum of 100% Standard Proctor Maximum Dry Density (SPMDD) in 0.3m lifts. Tests shall be taken along the centerline of the proposed watermain. All fittings and branch valves in fill areas shall be restrained.

20.03 MAIN LINE VALVES

20.03.01 SIZING

Main line valves shall be the same size as the watermain.

20.03.02 NUMBER AND LOCATION

Two valves are required to isolate a tee intersection and three valves are required to isolate a cross intersection. These valves are to be located close to the intersecting pipes if possible. Valve required on each side of a railway crossing or at each end where the watermain is installed in a casing.



Main line valves should be spaced so no more than two (2) hydrants are installed in between the valves (approximately 300m) for up to and including 400mm diameter. For watermains larger than 400mm diameter, spacing shall be approved on a per project basis by the Director, Water Engineering.

20.03.03 VALVE BOXES

All valves smaller than 400mm in diameter shall be equipped with valve boxes and restrained. All valves and fittings protected by an anode and zinc anode caps.

All valves 400mm diameter and larger shall be equipped with valve boxes and restrained.

The top of the valve box covers shall be set flush with finished grade and remain accessible at all times.

20.03.04 VALVE BOX PROTECTION

All main line valve boxes and hydrant branch valve boxes are to be protected during construction and during the maintenance period. Valve boxes are to be brought flush with grade prior to final approval.

20.04 HYDRANTS

Hydrants are to adhere to the specifications as described in the WUC's list of approved products.

20.04.01 SPACING

Hydrants are to be installed on 150mm diameter and larger watermains with the following being the maximum allowable spacing measured along the right-of-way:

- 150m in Residential Areas
- 100m in Industrial, Commercial, Institutional, and High Density Residential areas

High Density Residential can be defined as lots 15m and under in width.



The above maximum spacing may be altered at the Fire Department or WUC's request.

Verify adequate fire protection for large buildings (i.e., distance to Siamese connection).

When replacing existing hydrants use the same location if possible. If a new location is required, notify the homeowner in writing prior to engineering approval and provide proof of notification to the WUC. Where an existing hydrant does not meet current spacing standards, the current standard shall apply.

A 12 gauge AWG copper clad steel, blue coloured HDPE coated tracer wire must be installed and brought to the surface of each hydrant. The tracer wire is to be attached to an approved access box and secured to the hydrant flange.

20.04.02 BRANCH VALVES AND BOXES

All hydrants shall have 150mm branch valves and boxes. Hydrant branch tees from watermains made on concrete pressure pipe shall be flanged. All hydrant branches from watermains shall be restrained as per Standard Drawing 50.04.01 and 50.04.02.

20.04.03 LOCATIONS

The location of the hydrants in relation to the street line shall be in accordance with the City of Windsor approved relevant cross-section. Any non-standard location will require individual approval. Install hydrants near all intersections if possible.

Hydrants near driveways shall be located a minimum of 1.2m clear from the projected garage (or edge of driveway, whichever is greater) in residential applications and 2.4m separation in ICI areas. In subdivisions, hydrants are to be located at the Developer's / Builder's expense if the above minimum requirements are not met.

If subsequent changes are made to the property or design during construction (i.e. driveway widening, entrance feature, etc.), all costs associated with the relocation shall be borne by the Developer, Builder or property owner.

20.04.04 DEPTH OF BURY

The depth of bury for the hydrant shall be 1.7m (5.6 feet) unless otherwise stated by the Director, Water Engineering.



The hydrant safety breakaway flange must be located 0mm to 75mm above finished grade and field adjusted if required. Hydrant extension to adjust the length of a hydrant barrel, if necessary, shall be obtained from the manufacturer supplying the hydrant and installed as per manufacturer's directions.

20.04.05 AIR VALVES

For watermains larger than 400mm in diameter, provision for air release valves may be required. Locations to be determined by the Director, Water Engineering.

20.05 WATER SERVICES

All water services shall be single service connections and be supplied as described:

Only one water service shall be connected to the watermain per property unless approved by Water Engineering.

All unutilized water services and utilized services for future re-development shall be abandoned per 20.05.03.

Installation of watermain "stubs" or pre-servicing for future development should be avoided unless confirmation can be made stating that these undeveloped lands will be developed in the near future, complete with an approved site plan.

Note: Where non-metallic service pipe is installed, a 12 gauge AWG copper clad steel, blue coloured HDPE coated tracer wire must be installed with and along the pipe. Tracer wire to run along curb box rod and connect to nut on curb box lid as per Standard Drawings 50.07.01, 50.07.02, 50.07.03, and 50.12.01.

20.05.01 SERVICE SIZING

The minimum nominal service size shall be 25mm (1 inch) from the watermain to the property line. For services 100mm (4 inch) or larger, pressure testing and bacteriological testing is required. For pressure testing of a fire service line systems, must be tested to 1380 kPa (200 psi) and hold the pressure for one hour.



The service shall not exceed the diameter of the watermain without prior approval from Water Engineering. The Director, Water Engineering must approve services sized larger than 300mm or alternate service sizing.

Service size to be determined by The City of Windsor Building Department and Water Engineering.

20.05.02 SERVICE LOCATION

The service location shall be located as detailed on the City of Windsor servicing and/or road crossing section drawing unless otherwise approved. In Subdivisions services should try and be installed near the centre of each lot.

Water services must be installed perpendicular to the road and/or the watermain. Wherever practical the service shall be installed in the center of the lot frontage.

All water services shall have a 2.4m horizontal separation from all sewers and a 1.2m horizontal clearance from structures.

In cases where a fire and domestic service are required one connection from the watermain is made and branched off into two services before the property line.

In situations where a fire service is required and a public hydrant is not at a sufficient location to the Siamese connection a private hydrant may be installed. This hydrant is to be maintained annually per by-law 94.

Any modifications to the properties water service that requires the service to be replaced, enlarged, and/or modified will require the property to follow all current WUC Guidelines and Specifications regarding servicing and metering.

20.05.03 SERVICE ABANDONMENTS

Water services to be abandoned at locations determined by WUC Design Guidelines and Specification Standard drawings 50.10.01A and 50.10.01B. An abandonment permit is required with a deposit amount noted in WUC Schedules and determined by Technical Services and Water Engineering. The abandonment shall be witnessed by a Water Distribution Operator only. After the abandonment is completed the abandonment deposit will be refunded.



20.05.04 DEPTH

All water services to be 1.5m in depth.

Where the above mentioned requirements cannot be satisfied, refer to Standard Drawing 50.01.02 for insulation requirements.

20.05.05 RESTRAINTS

Services 100mm and larger, including valves, joints, and bends, regardless of size shall be fully restrained from the watermain to the property line.

20.05.06 MAINSTOPS

All water services shall have the same size mainstop as the service pipe. Mainstops are not required on water services greater than 50mm diameter.

Any residential services installed on a PVC watermain will require the use of an approved service saddle found in 40.14.01.

Service saddles are required for all services connected to concrete pressure pipe manufactured to the latest edition of AWWA C301 and AWWA C303 specifications for all tap sizes.

20.05.07 CURB STOPS AND BOXES

All services shall have curb stops and boxes installed at the property line, be flush with grade and accessible at all times. Reducing curb stops shall not be used.

For residential applications, all water service curb stops and boxes to be installed in grass areas with a minimum distance of 1m from the edge of the driveway if possible.

20.05.08 METERING

All water services shall be metered. All water meters to be installed by WUC Design Guidelines and Specification Standard drawings only unless otherwise approved by



Water Engineering. All meters shall be accessible at all times. Metering option to be decided by Water Engineering on a case by case basis.

20.05.09 BACKFLOW PREVENTION

A premise isolation backflow preventer is required for all ICI properties. All new developments require an RP type backflow preventer to be installed right at the point of

entry to the building and before any other connections are made to the plumbing system. A DCVA type backflow may be installed on existing ICI buildings if there is a minor threat of cross contamination. The contamination risk to be determined by an approved plumber and Water Engineering. Other backflow preventers on the premise may be required, see Ontario Building Code (OBC) and Canadian Standards Association (CSA) requirements.

20.05.10 ELECTRICAL GROUNDING

On reconstruction or local improvement projects where existing structures will be serviced by a replacement or new water distribution system, the Engineer shall determine if the electrical grounding systems are connected to the water service. If so, appropriate measures must be taken to ensure that electrical grounding systems are not compromised. Possible solutions include using copper services or installing new grounding rods or plates (see the Electrical Safety Code).

20.06 CONNECTION PROTOCOL

See paragraph 20.02.02 if this guideline for definition of Classifications

Transmission

- No connections permitted on feeder mains or water mains
- No service connections allowed

Feeder mains

- Connections with other feeder mains and distribution mains permitted



- No service connections allowed
- Industrial connections may be considered under special circumstances when no other options are presented

Distribution Mains

- All types of service connections permitted

20.07 CORROSION PROTECTION

Non-Metallic Watermain

Non-metallic watermain with metallic fittings and non-metallic service laterals shall install a 10.9Kg. (24lb.) zinc anode to each fitting.

The anode locations shall be clearly shown on the Construction Drawings.

Corrosion Protection for concrete pressure pipe shall be considered on a project by project basis.

Metallic Watermain

As part of the Geotechnical Investigation, the resistivity and corrosiveness of the soil must be determined.

Where metallic watermains are to be installed, an appraisal must be done to determine if corrosion protection is required. This appraisal shall be performed using the 10-point soil evaluation procedure as described in AWWA C105 Appendix. If the 10-point soil evaluation establishes a need for corrosion protection, the necessary anode spacing shall be clearly shown on the Construction Drawings.

Approved methods for corrosion protection of Ductile Iron watermain fittings are:

- Sacrificial anodes
- Petrolatum tape systems
- Hyprotec Coating



WINDSOR
UTILITIES
COMMISSION

WINDSOR UTILITIES COMMISSION WATER DIVISION CITY OF WINDSOR

DESIGN GUIDELINES AND SPECIFICATIONS FOR THE INSTALLATION OF WATER MAINS AND SERVICES

PART 30 SPECIFICATIONS FOR INSTALLATION

Revisions

Nov. 2013 – add 30.15.07 Thermal Butt Fusion

June 2014 – Revise 30.32 and 30.35

August 2015 – add 30.18.09 and 30.22.03

November 2015 – Revise 30.03.06, 30.03.08, 30.03.09, 30.04.01,
30.04.02, 30.04.03, 30.08.01, 30.08.08, 30.14.02,
30.18.03, 30.21.03, 30.22.02, 30.26.01, 30.33.02,
30.35.01, 30.43.02, 30.48, 30.53

August 2016 – Revise City Specification portion

October 2016 – Revise 30.21.01, 30.21.02, 30.21.03, 30.22.01, 30.22.02
30.23.01

November 2022 – Revised 30.21.04

December 2023 – add 30.16.01

December 2024 - Revised 30.19.01



SPECIFICATION FOR INSTALLATION OF NEW WATER MAIN

30.01	GENERAL-----	1
30.02	SITE PREPARATION-----	1
30.03	REMOVALS & ABANDONMENTS-----	1
30.04	PRESERVATION AND PROTECTION OF EXISTING FACILITIES-----	2
30.05	PROTECTION AGAINST FLOATATION-----	2
30.06	COLD WEATHER WORK-----	2
30.07	TRANSPORTING, UNLOADING, AND HANDLING PIPE-----	3
30.08	EXCAVATION FOR MAINS, SERVICES, APPURTENANCES AND TIE INS-----	3
30.09	SUPPORT SYSTEMS (TRENCH BOX, ETC.)-----	5
30.10	DEWATERING-----	5
30.11	PROTECTION SCHEMES-----	5
30.12	PROTECTION OF TEMPORARY WATER MAINS AND SERVICES-----	5
30.13	BACKFILLING AND COMPACTING-----	5
30.14	INSTALLATION OF PIPES-----	6
30.15	JOINTING-----	6
30.16	CUTTING OF PIPE-----	6
30.17	CHANGES IN LINE AND GRADE (GENERAL)-----	6
30.18	INSTALLATION OF WATER MAIN APPURTENANCES-----	6
30.19	CATHODIC PROTECTION OF NEW AND EXISTING WATER MAINS AND FITTINGS-----	8
30.20	EXISTING SITE CONDITIONS FOR NEW WATER SERVICES-----	9
30.21	GENERAL NOTES ON WATER SERVICES-----	9
30.22	INSTALLATION AND/OR REPLACEMENT OF SERVICE FROM MAIN TO PROPERTY LINE-----	10
30.23	SERVICE TRANSFER-----	11
30.24	WATER MANHOLES AND VALVE CHAMBERS-----	11
30.25	METERS AND METER CHAMBERS FOR SERVICES-----	11
30.26	TEMPORARY RESTORATION OF SIDEWALKS AND PAVED AREAS-----	11
30.27	FLUSHING, DISINFECTING WATER MAIN AND SERVICES-----	12
30.28	HYDROSTATIC TESTING-----	12
30.29	CHARGING NEW SERVICES-----	12
30.30	OPERATING WATER VALVES AND HYDRANTS IN ROW-----	12
30.31	OPERATING WATER VALVES AND HYDRANTS IN PRIVATE PROPERTY-----	12
30.32	CONNECTIONS TO EXISTING WATER MAINS IN ROW-----	13
30.33	CONNECTIONS TO NEW WATER MAINS IN ROW-----	15
30.34	CONNECTIONS OR REPAIRS TO EXISTING-----	15
30.35	REPAIRS TO EXISTING WATER MAINS AND SERVICES DAMAGED DURING CONSTRUCTION-----	15
30.36	TEMPORARY WATER MAINS, SERVICES AND HYDRANTS-----	15
30.37	TEMPORARY WATER SERVICES IN SPECIAL CASES-----	15
30.38	CLOSED CIRCUIT TELEVISION INSPECTION OF PIPELINES-----	16
30.39	SEWER PIPE INSTALLATION IN OPEN CUT-----	16
30.40	INSTALLATION OF CULVERTS FOR HYDRANT ACCESS-----	16

30.41	REPAIR AND/OR INSTALLATION OF SEWERS, SEWER CONNECTIONS, CATCH BASIN LEADS AND CULVERTS-----	16
30.42	ADJUSTING OR REBUILDING MAINTENANCE HOLES, CATCH BASINS, DITCH INLETS AND VALVE CHAMBERS-----	16
30.43	RELOCATION OF CATCH BASIN, ETC.-----	16
30.44	CONCRETE WORK-----	16
30.45	ADJUST WATER VALVE BOXES AND CURB BOXES-----	16
30.46	COLD MIX ASPHALT SHALL BE AS PER OPSS-----	16
30.47	UNTREATED GRANULAR, SUB BASE, BASE, SURFACE, SHOULDER AND STOCKPILING-----	17
30.48	GRANULAR MATERIAL-----	17
30.49	RECLAIMED MATERIAL-----	17
30.50	RESTORING UNPAVED ROADWAY SURFACES-----	17
30.51	ASPHALT CURB AND GUTTER SYSTEMS-----	17
30.52	CONCRETE CURB AND GUTTER SYSTEMS-----	17
30.53	HOT MIX ASPHALT PAVEMENT FOR ROADWAYS, DRIVEWAYS, AND SIDEWALKS-----	17
30.54	CONCRETE PAVEMENT AND CONCRETE BASE FOR ROADWAYS, DRIVEWAYS, AND SIDEWALKS-----	17
30.55	INSTALLATION OF INTERLOCKING CONCRETE PAVERS-----	18
30.56	RESTORATION/ REPAIR OF CONCRETE PAVEMENT-----	18
30.57	RESTORATION OF CONCRETE BASE WITH ASPHALT PAVEMENT-----	18
30.58	RESTORATION OF FULL DEPTH ASPHALT PAVEMENT-----	18
30.59	SITE RESTORATION OTHER THAN ROADS AND SIDEWALK-----	18
30.60	CLEANLINESS-----	18
30.61	TRAFFIC CONTROL SIGNING-----	19
30.62	SITE OFFICE-----	19
30.63	TOILET FACILITIES-----	19
30.64	CATHODIC PROTECTION OF EXISTING WATER MAINS-----	19



SPECIFICATIONS FOR THE INSTALLATION OF WATERMANS AND SERVICES

ITEM NO	WUC SPECIFICATION -CONSTRUCTION	WUC STD. DRAWINGS	CITY OF WINDSOR SPECIFICATION	OPSS STANDARD
30.01	GENERAL			
30.01.01	The order in which this Specification applies shall be as follows: 1. WUC Specifications as noted in this column. 2. WUC Standard Drawings. 3. City Of Windsor Specification 4. OPSS & OPSD When WUC or City Specifications are silent on any issues, the OPSS will be applicable.			
30.02	SITE PREPARATION			
30.02.01	General Site preparatory work shall be performed prior to the installation of the water pipelines as follows:			
30.02.02	Removal of Existing Signage		Supplementary Specs. Sec. 29(2008)	543.07.02
30.02.03	Clearing and Grubbing			201.07.01, 201.07.02 , 201.07.03, 201.07.04, 201.07.05, 201.07.06
30.02.04	Shrub and Tree Removal or Relocation The Contractor shall remove all trees and shrubs wherever required. The tender price quoted for the installation of water plant and appurtenances shall provide for salvaging and relocation of the trees or shrubs to locations designated by the Engineer or alternately complete removal and disposal by the Contractor at his expense. No trees or shrubs shall be removed until the Engineer has confirmed that such removal is in order and the owner of such trees or shrubs has been contacted to determine whether the trees or shrubs are to be salvaged.			
30.02.05	Tree Protection and Pruning		SUP SPEC 2	565.07.01, 565.07.02, 565.07.03
30.02.06	Stripping and Stockpiling Topsoil			206.07.03.07, 570.07.01
30.02.07	Removal of Fences and Guide Rails		S-3 Sec 1.14, S-3 Sec. 1.11	503.07.07 510.07.04.01
30.02.08	Management of Excess Material		S-3 Sec 1.10, S-1 SS 3.1.8	180.07.01
30.03	REMOVALS & ABANDONMENTS			
30.03.01	General			510.07.01.02
30.03.02	Salvage Wherever possible, hydrants, valves, manhole covers, meter pit lids that can be salvaged shall be removed and returned to WUC stock.		S-3 Sec 1.11	510.07.01.03
30.03.03	Cutting Pavement, Side Walk etc.		S-1 SS 3.1.4	510.07.06.02
30.03.04	Removal of Concrete Pavement, Curb, Gutters, Driveways, Side Walks		S-1 Sec SS 3.1.4 S-3 Sec 1.14	
30.03.05	Removal of Asphalt Pavement, Driveway etc		S-1 Sec SS 3.1.4	
30.03.06	Removal of Hydrants, Valves, Manholes, Chambers, Meter Pits, etc. Excavate and remove abandoned hydrants, close old valves and remove old valve boxes and manholes. Fill holes with compacted granular material or non shrink fill.			



SPECIFICATIONS FOR THE INSTALLATION OF WATERMANS AND SERVICES

ITEM NO	WUC SPECIFICATION -CONSTRUCTION	WUC STD. DRAWINGS	CITY OF WINDSOR SPECIFICATION	OPSS STANDARD
30.03.07	<p>Removal of Curb Boxes The contractor shall, unless otherwise instructed by the Engineer, remove and dispose of existing curb boxes following the installation of new private services complete with curb box. The cost to remove the old water curb boxes is to be included in the Tender Unit Prices for the Installation of New Water Services. No additional payment will be made for these removals.</p>			
30.03.08	<p>Removal of Pipes or Abandoning pipes Water mains 350mm or greater shall be filled with 4Mpa non shrink grout.</p>			510.07.03.06, 510.07.03.07
30.03.09	<p>Cold Mill Existing Asphalt Surface</p>		S-42	510.07.06.05
30.04	PRESERVATION AND PROTECTION OF EXISTING FACILITIES			
30.04.01	<p>General Locates shall be called in from all utilities before any actual work commences. The relevant railway companies shall be informed in advance if there is any work on railway property or if the work hinders railway operation. Test pits or vacuumed holes shall be dug if necessary to locate the existing utilities before actual work is started. Where the trench crosses sewers, drains, watermains, gas mains or other underground structures, the Contractor shall carry out the work with extreme care so as to avoid damage. If any of these pipes or services are broken or damaged, they shall be repaired by the Contractor at his own expense. All pipes crossing or lying within the trench shall be adequately supported, as required by Cof W specifications and Ministry of Labour, in order that they will not be damaged by their own weight or by the loads resulting from the settlement of the backfill materials. Refer to City of Windsor Specification.</p>		S1-Sec SS1.3 & 1.7 S-39	
30.04.02	<p>Support and Repair Utility Crossing The existing sewers, catch basin leads and drains shall be supported as per City of Windsor and Ministry of Labour Specifications, except as noted below. When the earth has been removed from the top of the pipe, the pipe shall be temporarily suspended from timbers spanning across the trench at ground level to provide adequate support. Suspending cables shall be well tightened to prevent sagging of the pipe. The temporary supports for the pipe shall remain in place until the permanent supports have been completed.</p>		S-1 Sec SS 1.7 AS 312	
30.04.03	<p>Support of Water, Gas main, and Bell cable. Water or gas mains or Bell cables crossing the trench shall be supported by means of timber placed on top of concrete support similar to the support for sewers, as described above. A 50 mm (2 in.) plank of sufficient width shall be placed under the water or gas main and the concrete support poured to the underside of the wooden plank. Concrete shall be as per City of Windsor and Ministry of Labour Specification.</p>			
30.05	PROTECTION AGAINST FLOATATION			441.07.05
30.06	COLD WEATHER WORK			
30.06.01	<p>WUC Engineer may permit or order work to be done in cold weather. The Contractor shall take all precautions to protect the work so that injury or damage to the work will be prevented as per applicable OPSS Standards. The Contractor shall at his entire expense furnish all equipment, material and labour.</p>		SS-1.5	441.07.06 408.07.04 408.07.05



SPECIFICATIONS FOR THE INSTALLATION OF WATERMANS AND SERVICES

ITEM NO	WUC SPECIFICATION -CONSTRUCTION	WUC STD. DRAWINGS	CITY OF WINDSOR SPECIFICATION	OPSS STANDARD
30.07	TRANSPORTING, UNLOADING, STORAGE AND HANDLING PIPE			
30.07.01	Water pipe shall be delivered to the job site with factory-installed end-caps. The Water Engineering department will approve the end-caps and the method of securing the caps to the pipe. A sample of the capped pipe with a clear date stamp shall be delivered to the Director of Engineering's office for pre-approval. The capped pipe sample should be an accurate representation of the product to be delivered to the work site and such will serve as an example which inspectors will base their decision to reject or accept pipe for installation. Upon approval, a letter will be issued to the manufacturer, which will serve as a certificate of approval. Changes made to the end-cap system by the manufacturer will require samples to be resubmitted for approval. Failure to comply with this request may result in the rejection of the pipe.			441.07.07
30.07.02	The possibility exists that the capping system could be damaged or missing before the pipe is installed. If this occurs, WUC inspectors will make a decision along the following guidelines: a) If it appears that the shipment originated from the factory and only a few end-caps and sealing tape is damaged or missing upon arrival, then the inspector may allow the pipe to be used provided the interior of the pipe in question is field cleaned moments before installation. b) If numerous caps are missing, giving the impression that non-approved pipe is being supplied, then all pipes in question shall be rejected. c) If numerous end-caps or sealing tape are of suspect, giving the impression that someone other than the manufacturer installed the caps, then all pipes in question will be rejected.			
30.07.03	Cut pipe lengths shall be allowed for installation provided that the pipe interior is field-cleaned moments before installation. Due to their short length and accessibility for field cleaning, end-caps are not required for fitting and valves. NOTE: Field cleaning is defined as the removal of all material along the entire length of the interior of the pipe by method of swabbing with a 1% hypochlorite solution.			
30.08	EXCAVATION FOR MAINS, SERVICES, APPURTENANCES AND TIE INS			
30.08.01	Safety All excavation work for watermains, water services, and structures shall be carried out in accordance with the current edition of the Occupational Health and Safety Act for Construction Projects and Regulations for the Province of Ontario and all other rules and regulations governing this type of work, in particular, the Contractor shall ensure that his forces comply with the Regulations governing work in excavations and confined spaces, as well as in the proximity of high voltage hydro lines and high pressure gas mains. Contractor shall install a 1.8m fencing around construction area per Ministry of Labour Specifications. Refer to: Occupational Health and Safety Act, R.S.O.1990, C.O.1 as amended Ontario Regulations 213/91 - Regulations for Construction Projects			538.02 Occupational Health and Safety Act, R.S.O.1990, C.O.1 as amended Ontario Regs 213/91 - Regulations for Construction Projects
30.08.02	Depths, Grades and Alignment The trenches shall be excavated to the depths and grades, as shown on the Drawings. The new watermain and water services shall be installed to a depth of 1.68 m (5.5 ft.) +/- 0.30 m (1.0 ft.) to the top of the pipe, unless otherwise ordered by the Engineer. Any additional depth ordered by the Engineer and not specified or shown on the Drawings shall be paid for at a price agreed upon by the Contractor and the Engineer. A deduction will be made for any depth less than the specified depth at the same rate as that paid for additional depth. In calculating additional or reduced excavation, the width of the trench shall be 600 mm (24 in.) greater than the nominal diameter of the pipe but no allowance will be made for slopes or bell holes.			



SPECIFICATIONS FOR THE INSTALLATION OF WATERMANS AND SERVICES

ITEM NO	WUC SPECIFICATION -CONSTRUCTION	WUC STD. DRAWINGS	CITY OF WINDSOR SPECIFICATION	OPSS STANDARD
30.08.03	<p>Trench Width The trench shall be excavated of sufficient width to provide for the proper sheeting, shoring and bracing of the sides of the trench, as specified in Part III of The Occupational Health & Safety Act, 1980 and Regulations for Construction Projects, and the proper laying and jointing of the pipe. Trench walls shall be vertical to 300 mm (12 in.) above the top of the pipe and the width at this location shall not exceed the maximum. Trench width for a single pipe shall be as per WUC Standard Drawings.</p>	50.01.01		
30.08.04	Maximum Length of Open Trench		S-1 Sec SS 3.1.2	
30.08.05	<p>Deviations Due to Unknown Underground Obstructions WUC normally will not relocate any utilities for the construction of watermains. Under unusual situations, any relocation shall be installed as per City of Windsor Specification Prior approval from WUC shall be obtained. (a) The exact location and elevation of existing utilities is to be verified by the Contractor prior to installation of watermain and water services, in order to avoid any conflict with the new watermain installation. The Contractor shall include the cost for this exploratory excavation and backfill work in his tender price for the installation of the watermains, water tie-ins, and water services in appropriate Schedule of Items and Prices. (b) Expose existing utilities by hand digging. (c) Expose existing utilities, as specified, at least 0.5 km (1,600 ft.) ahead of the trenching machine. (d) No mechanical excavation is permitted within 1.0 m (3 ft.) of an existing utility. (e) No adjustment in the price tendered will be made unless the actual measured distance from top of watermain to ground level varies from that shown on the drawing by 0.3m or greater. The Contractor will be asked to change the profile up or down by 300mm in order to avoid conflicts with sewer connections.</p>		SS-1.6	
30.08.06	<p>Excavation for Watermain Tie-Ins, Services and Bore Pits, etc. The excavation to be paid for shall be based on a depth of trench from the surface of the ground or pavement to the bottom of the pipe and a width of trench for a single pipe. For connecting pipes, excavation of 600mm (24 in.) plus nominal diameter of pipe will be paid. Excavation for water services must allow sufficient space to complete all aspects of water service installations (i.e. tapping, punching, tie-ins, etc.). If extra space is required for the carrying out of the work, the excavation shall be made at the expense of the Contractor.</p>			
30.08.07	<p>Excavation For Chambers For concrete chambers, excavation will be paid for a distance of 600 mm (24 in.) outside the footings of the chambers.</p>			516
30.08.08	<p>Directional Boring Where new watermain is to be installed by Directional Bore Trenchless Installation Method of Construction, the Contractor must use a fully restrained PVC watermain piping system designed specifically for "pull in place" application. Directional Boring must be carried out by Contractors/Sub-Contractors who are trained, equipped, and experienced in doing this type of work. As part of the Preliminary Investigation Work, the Contractor will be required to verify the locations and elevations of ALL underground utilities in the path of the bores by vacuum excavation to assure that no conflicts or damages will occur. Directional boring work shall be inclusive of all costs, including all investigation work, work pits, mobilization, demobilization, etc.</p>			450
30.08.09	<p>Conventional Boring Conventional boring will be allowed with WUC approval. Conventional boring operations will be stopped by WUC if line and grade cannot be maintained.</p>			



SPECIFICATIONS FOR THE INSTALLATION OF WATERMANS AND SERVICES

ITEM NO	WUC SPECIFICATION -CONSTRUCTION	WUC STD. DRAWINGS	CITY OF WINDSOR SPECIFICATION	OPSS STANDARD
30.08.10	Jacking and Boring		S1-SS 3.3.3	416.07.02, 416.07.06, 416.07.07, 416.07.08
30.08.11	Installation of Casing In Open Cut may be allowed with prior approval.			
30.09	SUPPORT SYSTEMS (TRENCH BOX, ETC.)			
30.09.01	Occupational Health and Safety Act, R.S.O.1990, C.O.1 as amended Ontario Regulations 213/91 - Regulations for Construction Projects		S-1 Sec 3.1.5	O H & S Act, R.S.O.1990, C.O.1 as amended On Reg 213/91
30.10	DEWATERING			517.07.01
30.10.01	Control of Water from Dewatering Operations			518.07.01
30.11	PROTECTION SCHEMES			441.07.11
30.12	PROTECTION OF TEMPORARY WATERMANS AND SERVICES			441.07.12.07
30.13	BACKFILLING AND COMPACTING			514.07.10
30.13.01	Bedding for Pipes The water main pipe shall be laid on this flat bottom trench with a minimum of 100 mm (4 in.) of compacted granular material under the pipe to give the pipe uniform support. Water service pipe shall be laid with a minimum of 50 mm (2 in.) of compacted granular material under the pipe.			
30.13.02	Cover for Pipes Backfill consisting of coarse sand (granular material) shall be placed in 150 mm (6 in.) layers under and around the underside of the pipe to a minimum of 300 mm (12 in.) above the top of the pipe and shall be thoroughly tamped and consolidated by hand tampers within the pipe zone. The balance of the backfill to the top of the pipe shall be placed in layers not exceeding 100 mm (4 in.) in thickness and thoroughly tamped by power tampers. If the rest of the back fill material is of aggregate size greater than 19mm, then the above coarse sand cover shall extend to a height of 600mm (24") above the pipe.	50.01.01		
30.13.03	Insulation at Shallow Cover	50.01.02		
30.13.04	Backfill Where the trench has been excavated in a roadway, it shall be backfilled above the limit of the granular fill for its full depth with granular material to City of Windsor specification or as specified otherwise. Where the trench has been excavated in boulevards or parkland, the remaining depth of trench shall be backfilled with good clean native material; compacted in 150 mm (6 in.) lifts to 95 per cent Standard Proctor Density and the top 150 mm (6 in.) shall be loam or stone.		Supplementary Specs. Sec 28 (2008) S-1 Sec SS 3.1.10 S-1 Sec 3.1.11 S-1 Sec 3.1.12 AS 310 A, B, C AS 519, AS 536	514.07.10.05 514.07.11
30.13.05	Removing of Sheathing and Sheet Piling		S-1 SS 3.1.12	
30.13.06	Special Bedding for Pipe (Concrete Cradle) as approved by WUC			
30.13.07	Bedding and Cover for Sewer Crossings and Connections.		S-1 Sec.SS 3.2.1	
30.13.08	Water Jetting Water jetting of water main trenches and water service pits are allowed only in areas where native materials are used as back fill. See city specifications for approved procedures.		S-1 Sec.SS 3.1.14	



SPECIFICATIONS FOR THE INSTALLATION OF WATERMANS AND SERVICES

ITEM NO	WUC SPECIFICATION -CONSTRUCTION	WUC STD. DRAWINGS	CITY OF WINDSOR SPECIFICATION	OPSS STANDARD
30.14	INSTALLATION OF PIPES			
30.14.01	<p>Installation of pipes in open cut Pipe shall be laid in a dry trench. Pipe shall be laid within the alignment and grade tolerances specified in the Contract Documents. The barrel of each pipe shall be in contact with the shaped bed throughout its full length. When the Owner raises or lowers the invert of a watermain by up to 300 mm, it will not constitute a Change in the Work and no adjustment will be made to the payment. Where the invert of a watermain is raised or lowered by more than 300 mm, then this shall constitute a Change in the Work for the full extent of the change from the original grade. Pipe shall be kept clean and dry as work progresses. A removable watertight bulkhead shall be installed at the open end of the last pipe laid whenever work is suspended.</p> <p>Price for installation of new watermain shall include the supply and installation of the watermain, trench excavation, granular bedding, granular backfill to grade, couplings, blocking, restraint devices and all other fittings not specified in other tender items.</p>			
30.14.02	<p>Spacing Between Two Pipes New watermain shall not be installed within 1 meter of any existing or proposed pipes including other watermain pipes. Separation from Sewers - In public ROW as per latest version MOE Design guidelines for Drinking Water Systems(Sec. 10.11.2 & 10.11.3 - 2008), Waterman Design Criteria for future alterations authorised under a Drinking Water Works Permit (Sec 15) and In private Property as per Ontario Building Code (Sec 7.3.5.7-2006or latest)</p>			
30.14.03	<p>Installation of Pipes in Casing Using Jack and Bore Pipe shall be installed complete with WUC approved spacers and end seals, installed per manufacturer's specifications</p>			416.07.05
30.14.04	Installation of Pipe by Tunnelling			415.07.04
30.15	JOINTING			441.07.15
30.15.01	General			441.07.15.01
30.15.02	Mechanical Joints for Ductile Iron Pipe and Fittings			441.07.15.02
30.15.03	Bell and Spigot Joints for Concrete Pressure Pipe and fittings			441.07.15.03
30.15.04	Bell and Spigot Polyvinyl Chloride Plastic Pressure Pipe and Fittings			441.07.15.04
30.15.05	Joints for Polyethylene Plastic Pressure Pipe and Fittings			441.07.15.05
30.15.06	<p>Jointing for Service Connection Pipe No joints to be installed between main and curb box.</p>			441.07.15.07
30.15.07	<p>Thermal Butt Fusion Contractor shall provide data log results in PDF or XLS format for all fused joints. Failure to provide data will result in non payment</p>			
30.16	CUTTING OF PIPE			441.07.16
30.16.01	<p>Pipe cutting and chamfering See pipe manufacturer's recommendations</p>			441.07.16
30.17	CHANGE IN LINE AND GRADE (GENERAL)			441.07.17.01
30.17.01	Concrete Pressure Pipe			441.07.17.02
30.17.02	Polyvinyl Chloride Plastic Pressure Pipe (PVC)			441.07.17.03
30.17.03	Polyethylene Plastic Pressure Pipe (PE)			441.07.17.04
30.18	INSTALLATION OF WATERMAIN APPURTENANCES			441.07.18
30.18.01	<p>Valves -General Valve price shall include all costs associated with valve boxes, thrust restraint, concrete support, tracing wire, granular back fill, etc.</p>	50.03.01		441.07.18.01
30.18.02	Air Release and Air/Vacuumed Valves			441.07.18.02



SPECIFICATIONS FOR THE INSTALLATION OF WATERMAINS AND SERVICES

ITEM NO	WUC SPECIFICATION -CONSTRUCTION	WUC STD. DRAWINGS	CITY OF WINDSOR SPECIFICATION	OPSS STANDARD
30.18.03	<p>Fire hydrants Supply and install fire hydrants (externally plugged) including thrust restrainers, tracing wire, concrete support, excavation, granular backfill, couplings, large zinc caps as specified and per WUC detail and Conduct Flow Testing and submit electronic results documentation to WUC and paint the new fire hydrant (barrel and caps) with proper colour coding as determined by the flow test.</p> <p>Installation of Hydrants The pumper connection shall face the centre line of Road for Hydrants in public Right of way. The pumper connection shall face the city approved fire route for hydrants on private property.</p> <p>Hydrant Painting and Flow Testing: The Contractor shall be responsible for flow tests on Hydrants in Subdivisions and private developments to determine full fire flow capacity in accordance to NFPA 291 " Fire Flow Testing and Marking of Fire Hydrants". Colour Code Fire Hydrants as required in accordance with NFPA291 standard. Submit the flow test results and the Fire flow capacity calculation to WUC Engineering for review and approval as per NFPA 291, cl 4.11. Approval must be obtained from WUC Engineering prior to performing any flow tests.</p> <p>Staging for Flow Testing: 1. All new watermain work must be 100% complete including all tie ins, services etc.</p> <p>2. Contractor must call WUC call centre to arrange for WUC representative to be on site to assist during flow testing. 3. Hydrants in the construction area shall not be used during the Flow Testing process. 4. Flow test results to be submitted electronically to Director of WUC engineering for review and approval. 5. Hydrant to be fully painted including barrel and caps. Colour coding is based on flow test results. 6. Private Hydrants do not have to be colour coded.</p> <p>The current list of approved contractors can be found at the following web address. http://www.wuc.on.ca/about/regulatory.bylaw_88.cfm</p>	50.04.01& 50.04.02		441.07.19 1105.010
30.18.03a				
30.18.04	<p>Thrust Restraints Only WUC approved mechanical restrainers will be allowed. On exceptional situations, concrete thrust blocking may be used with WUC approval. The length of watermain to be restrained shall be as per WUC standard drawings. Concrete pipes shall be restrained as per manufacturers recommendation.</p>	50.06.01		441.07.23 1103.01 1103.02
30.18.05	<p>Installation of Swabs Swabs shall be installed on all main lines, branches and hydrant leads. Actual locations shall be approved by the WUC Inspector. NO swabs shall be installed if the watermain has any Butterfly Valves. Must be identified (ie. numbered)</p>			
30.18.06	Blow Off Arrangement - Temporary	50.02.02		
30.18.07	Blow Off Arrangement - Permanent (shall be as per WUC Standard Drawing).	50.02.01		
30.18.08	Chlorine Riser and Sampling Points (shall be as per WUC Standard Drawing). Cost to include installation, excavation, backfill and removal after testing is complete.	50.02.03		



SPECIFICATIONS FOR THE INSTALLATION OF WATERMANS AND SERVICES

ITEM NO	WUC SPECIFICATION -CONSTRUCTION	WUC STD. DRAWINGS	CITY OF WINDSOR SPECIFICATION	OPSS STANDARD
30.18.09	<p>Tracer Wire Installation</p> <p>General: All tracer wire shall be copper clad steel and have HDPE insulation intended for direct bury and shall be blue in colour.</p> <p>Materials:</p> <p>Wire: <u>Open Trench:</u> - Tracer wire shall be #12 AWG Copper Clad Steel, High Strength with minimum 450lb. break load and minimum 30 mil HDPE insulation thickness <u>Directional Drilling:</u> - Tracer wire shall be #12 AWG Copper Clad Steel, extra high strength with minimum 1150lb. break load and minimum 30 mil HDPE insulation thickness <u>Pipe Bursting:</u> - Tracer wire shall be 7x7 Stranded Copper Clad Steel, extreme strength with 4700lb. break load and minimum 50 mil HDPE insulation thickness</p> <p>Connectors: All tracer wire shall be interconnected intersections, at tees and crosses. At tees wires shall be joined using a single 3-way lockable connector. At crosses the four wires shall be joined using two 3-way connectors with a short jumper wire between them shown in Detail A on Standard Drawing 50.12.01</p> <p>Termination / Access Points: <u>Hydrants:</u> - Tracer wire shall terminate at an approved above ground tracer wire access box, properly affixed to the hydrant grade flange at the back of the hydrant. All tracer wire access boxes shall include a manually interruptible conductive / connective link between the terminals for the tracer wire connection and the terminal for the grounding anode wire connections. Grounding anode wire shall be connected to the bottom terminal on all access boxes. See Standard Drawings</p>			
30.18.09 (Cont'd)	<p>50.04.01 & 50.04.02. For termination points at water services see Standard Drawings 50.07.01, 50.07.02, and 50.07.03.</p> <p>Grounding: Tracer wire shall be properly grounded at all deadends, stubs, valves or curb stops for private services, connections to existing watermains, and hydrants. Use minimum 1lb. drive-in magnesium grounding anode rod (unless otherwise stated on Standard Drawings) and connect it to the tracer wire using approved locking connectors. Do not coil excess wire from grounding anode. Trim wire to appropriate length before connecting to tracer wire with locking connector. Where anode wire will be connected to a tracer wire access box, a minimum of 2 feet of slack is required after meeting final elevation.</p> <p>Installation: Tracer wire installation shall be performed in such a manner that allows proper access for connection of line tracing equipment, proper locating of wire without loss or deterioration of low frequency signal. Tracer wire systems shall be installed as a single continuous wire, except where using approved locking connectors. Any damage occurring during installation of the tracer wire shall be immediately repaired by removing the damaged wire, and installing a new section of wire with approved locking connectors. Tracer wire shall be installed along the north or east side of the watermain pipe and taped at least once per pipe segment. All service lateral tracer wires shall be a single wire, connected to the mainline tracer wire using two 3-way locking connectors and a jumper piece shown in Standard Drawing 50.12.01 Detail B.</p> <p>Testing: All new tracer wire installations for watermain replacement and new subdivision watermain installations shall be tested by Enwin prior to acceptance into Maintenance period.</p>			
30.19	CATHODIC PROTECTION OF EXISTING WATERMANS AND FITTINGS			
30.19.01	<p>All iron fittings shall be CAD welded with a 10.9 Kg(24 lb) anode. All bolts and nuts on mechanical joints shall be capped with a sacrificial zinc nut. When an existing watermain is not cathodically protected, anodes shall be installed wherever the existing watermain or associated services are exposed during the course of other work (e.g. another utility installation or watermain break repair). CAD weld on mains and large D.I. or C.I. service pipes. All restrainers on a pipe that is 400mm (16") or larger shall have a 5.4kg (12 lb) anode CAD welded to each restraint device. Use approved connectors and clamps on service pipes. All flanged and mechanical joint systems shall be covered with a petrolatum tape corrosion protection system. Other ferrous metal surfaces shall be covered with a petrolatum tape corrosion protection system where shown on the drawings.</p>			



SPECIFICATIONS FOR THE INSTALLATION OF WATERMANS AND SERVICES

ITEM NO	WUC SPECIFICATION -CONSTRUCTION	WUC STD. DRAWINGS	CITY OF WINDSOR SPECIFICATION	OPSS STANDARD
30.20	EXISTING SITE CONDITIONS FOR NEW WATER SERVICES			
30.20.01	Examination of Site Conditions In most cases the exact location of the water services will be dictated by the existing utilities and/or site conditions as determined in the field.			
30.20.02	Prior to tendering the project, the Contractor must visit the job site and familiarize himself with existing site conditions and choose and size his equipment accordingly in order to do the least amount of damage as possible.			
30.20.03	Site Removals and Repairs The Contractor shall allow in his unit price for Water Service Installations, the cost to remove, relocate, repair, or replace any surface obstruction that interferes with new water service installations (i.e. shrubs, fences, mail boxes, flower beds, edging, decorative stone, etc.). In every case, the Contractor must contact the homeowner involved and confirm they are satisfied with the completed repairs or relocation work. Refer also to Item 2.4 " Shrubs and Tree Removal or Relocation".			
30.20.04	Wherever possible install water service piping by auguring or punching methods of construction. New water services are to be installed to a depth of 1.68 m (5.5 ft.) +/- 0.3 m (1.0 ft.) from the finished grade to the top of the pipe. Auguring or punching is required under all driveways, roadways, curbs, sidewalks, and trees.			
30.21	GENERAL NOTES ON WATER SERVICE			
30.21.01	No water service work shall be backfilled without first being inspected by WUC Engineer. ALL CUSTOMER COMPLAINTS to be responded to immediately. CONTRACTORS EMERGENCY TELEPHONE NUMBERS shall be provided. All remedial repair work shall be inspected by a licenced water operator. All work shall be done in the dry conditions. Dewatering by Contractor. Refer to WUC STANDARD DRAWINGS for details. The tapping machine must be in good working order. It is important that the boring bar is straight and the tapping bit is sharp and bleached prior to each use. The Contractor is to use couplings which properly adapt to the various sizes and materials of water services pipe encountered.			
30.21.02	Extreme care shall be taken to keep existing water service pipe clean and capped until the final tie-in can be made. No water service shall be cut or water meter removed without first installing a temporary jumper connection. If workers experience a shock or an arc occurs at the jumper when installed, notify ENWIN Power Lines immediately and no work is to proceed until the problem is rectified. Joints on copper piping installed underground shall be made with either flared or compression fittings. Refer to OBC . The boring for service pipes close to the tress shall be as per City Standard Drawings.			
30.21.03	Installation of water services using other conventional boring methods like hydraulic boring, mighty mole, etc. will no longer be permitted unless the contractor provides at his expense 2 vac holes, in locations determined by the WUC Engineer to confirm depth of cover. Pulling of existing water services is strictly prohibited. Ground plates shall be installed on all metallic water service pipes which are being replaced with plastic or PE pipes as per Canadian Electrical Code Part 1 Section 10-700, 10 -702 . Under special circumstances, a rod electrode may be allowed as per CSA 10-702 (3) with WUC approval. The grounding connector wire shall be #3 AWG TWU 600V Stranded Single Conductor. Refer to WUC Standard Drawings 50.07.03 for details. A 5.4 Kg Zinc Anode shall be installed on every metal water service as WUC Standard Drawing.			



SPECIFICATIONS FOR THE INSTALLATION OF WATERMANS AND SERVICES

ITEM NO	WUC SPECIFICATION -CONSTRUCTION	WUC STD. DRAWINGS	CITY OF WINDSOR SPECIFICATION	OPSS STANDARD
30.21.04	<p>Size of Service piping The minimum size of service piping shall be 25mm(1") from main to property line and 25mm (1") or 19mm (3/4") from property line to building. Larger size shall be approved by WUC. WUC may approve copper tubing from main to property line under special conditions. Servicing material shall be only from our approved list.</p>			
30.22	INSTALLATION AND/OR REPLACEMENT OF SERVICE FROM MAIN TO PROPERTY LINE.			441.07.20
30.22.01	<p>A new service shall be installed from the new main to property line as per WUC Standard Drawings. The new curb stop shall be installed as close as possible to the property line. The new service shall be tied in to the existing service as per WUC Standard Drawing on private property. The Contractor shall allow in his tender price for up to 1.5 m (5 ft.) of water service pipe installation on private property and the connection to the existing water service with the appropriate adapters and couplings. Expose and clean surface of main pipe in preparation for tapping. Install stainless steel tapping saddle on all watermains. Direct tapping will be permitted on iron mains with engineers approval. Install corporation main stop. Proceed to tap using an approved tapping machine. Excavate at property line as indicated by the Engineer. Punch or open cut only allowed when directed by WUC engineer and install polyethylene (P.E.) service pipe, include tracer wire. Connect service tracer wire to mainline tracer wire. Use approved connectors and waterproofing tape.</p>			
30.22.02	<p>Use approved connectors and waterproofing tape. Connect P.E. service pipe to main stop (use inserts). Connect P.E. service pipe to curb stop (use inserts). Turn on main stop and curb stop and flush out new P.E. water service. Shut curb stop. Locate and expose the existing water service on private property. Notify homeowner of water disruption (give ample notice prior to shut off). Install temporary jumper connection. Install permanent ground plates. Cut and connect existing water service to new curb stop (use poly, water pipe and inserts). Test new water service for leaks. Notify homeowner of water turn on, flush service at house. Install new curb box on curb stop and remove old curb box and rod. Extend tracing wire up curb box and connect wire under the lid (use clamp).</p> <p>Unit Price for installation of new water services shall include the supply and installation of new water service pipe, excavation, bedding, backfill, backfill in driveways (per C.O.W Spec S-29.05), expose, clean and tap watermain, perform directional drilling and connect to the existing water service pipe, tracing wire, stainless steel double bolt service saddles with Belleville washers, main stops, curb stops, boxes, ground plates, zinc anodes, any other necessary couplings to reconnect to existing water service, abandoning existing service and any other work or materials not specified in other tender items (trenching will only be permitted where ordered by the Engineer and conventional boring will only be permitted when contractor provides 2 vac holes to verify depth at his expense).</p> <p>When meter pits are encountered, the following procedure will apply: The Contractor to install a new meter pit (if required) in a new location as directed by WUC Engineer (including Meter and Copper Riser Piping). Connect new meter riser piping to existing water service and new curb stop. The Contractor will install ground rods, if necessary, as directed by WUC Engineer.</p>			
30.22.03	<p>Water Service Installation notes for Capital Projects and Subdivisions:</p> <p>To ensure water quality is maintained throughout the water service replacement or installation process, the following instructions shall be enforced:</p> <ol style="list-style-type: none"> 1. New water services installation must commence at the source end of the project and continue in consecutive order until all long and short services have been transferred or installed to the new system. 2. New water services must be installed in sequence prescribed by Water Engineering. At no time shall water services be installed out of sequence without approval of Water Engineering. 3. New water services must be installed independent of any sewer operations, utilizing only tools dedicated to water service work. 4. New water services must not be installed in a common trench with a sewer pipe unless otherwise approved by Water Engineering. <p>Any damage to existing water services shall be repaired at the contractor's expense, including "Boil Water Advisory" related costs</p>			



SPECIFICATIONS FOR THE INSTALLATION OF WATERMANS AND SERVICES

ITEM NO	WUC SPECIFICATION -CONSTRUCTION	WUC STD. DRAWINGS	CITY OF WINDSOR SPECIFICATION	OPSS STANDARD
30.23	SERVICE TRANSFER			
30.23.01	Under certain conditions if the existing service is of copper, WUC may decide to transfer the existing service to the new main. Service transfer in ROW shall be as per WUC standard drawings. The following procedures must be strictly adhered to. Expose and clean surface of main pipe in preparation for tapping. Install stainless steel tapping saddle on all watermains. Install corporation main stop. Proceed to tap using an approved tapping machine. Locate, expose, and clean old water service at the old water main to allow old main stop to be shut and old water service replaced. A minimum of 1.0m clearance is recommended at the sides of both water mains to allow proper service pipe installation. Prior to cutting away old metallic water service, Contractor must install a temporary jumper connection. Install ground plate. Notify homeowner of water disruption (give ample notice prior to shut off).			
30.23.02	Install anode to active copper water service using approved clamps, connectors, and mastic wrap. Connect tracing wire from main line tracing wire to the existing copper water service using approved connectors and mastic wrap. Turn old water service off by closing old main stop. Install new polyethylene water service pipe from newly installed main stop at new P.V.C. watermain to an approved tie-in location shown on drawings or directed by the Engineer. Turn on main stop and flush out new P.E. water service. Cut old water service away and connect new P.E. service to existing copper service using approved coupling. Notify homeowner of water turn on, flush service at house and test new water service for leaks. Unit Price for service transfer shall include the supply and installation of new water service pipe, excavation, bedding, backfill, granular backfill in driveways, expose, clean and tap watermain, perform punching and connect to the existing water service pipe, tracing wire, stainless steel double bolt service saddles, main stops, ground plates, zinc anodes, any other necessary couplings to reconnect to existing water service, abandoning existing service and any other work or materials not specified in other tender items (trenching will only be permitted where ordered by the Engineer).			
30.23.03	Remove and dispose of old water service debris from trench. In some cases, it may not be feasible to excavate at the main to shut the old main stop. In these cases, the Engineer may allow the Contractor to squeeze, cut, and tie back the old copper water services as required. It will be the Contractor's responsibility to re-excavate any squeezed services that are found leaking prior to the abandonment of the old water main at his expense.			
30.24	WATER MANHOLES AND VALVE CHAMBERS			
30.25	METERS AND METER CHAMBERS FOR SERVICES			
30.25.01	Meters will be provided by WUC at the written request of the customer. They will also be maintained by WUC. All meter pits shall be installed in the location specified by WUC.			
30.25.02	Meters which are in meter chambers or in meter pits shall be as per WUC Standard Drawings. Alternatively WUC may install buried meters at the property line. All meters shall not be installed until flushing and testing is complete.			
30.26	TEMPORARY RESTORATION OF SIDEWALKS AND PAVED AREAS			
30.26.01	After the backfilling of any section of trench has been completed, all sidewalks and paved areas which have been cut out shall be replaced with Granular "A" material. The temporary gravel areas to extend for the full width of the original work area and must be graded and compacted smooth to permit safe traversal by pedestrians and vehicles. NOTE: In alternative situations (i.e.. high traffic areas) Contractor shall install a cold patch or temporary asphalt surface over granular area in all intersections or as directed by the Engineer			



SPECIFICATIONS FOR THE INSTALLATION OF WATERMANS AND SERVICES

ITEM NO	WUC SPECIFICATION -CONSTRUCTION	WUC STD. DRAWINGS	CITY OF WINDSOR SPECIFICATION	OPSS STANDARD
30.27	FLUSHING & DISINFECTING WATERMAIN AND SERVICES			
30.27.01	Flushing New Watermain and Services Greater than 50mm in Diameter. All new water mains and services shall be flushed by WUC personnel as per DWQMS approved standard operating procedures. It is the contractors responsibility to provide adequate removal locations for waste water from flushing procedure.			
30.27.02	Disinfecting Watermains and Services Greater than 50mm in Diameter. All new watermains and services shall be disinfected by WUC personnel as per DWQMS (SOP-DWQMS-Disinfection of New Watermain) approved procedures.			
30.27.03	Services and Service Mains From 25mm to 50mm in Diameter. Normally services up to 50mm in diameter need not be disinfected and or pressure tested using approved procedures. They shall be thoroughly flushed and visually inspected for any leaks. However, under certain circumstances, WUC may flush, sample and pressure test the services and service mains especially if the service feeds more than one building or if it is a part of a larger network of services.			
30.28	HYDROSTATIC TESTING			
30.28.01	General All watermains and services three inches and larger shall be pressure tested by WUC only. All new watermains shall be tested at a pressure of 1035 Kpa (150 psi) for 2 hours. The fire mains and the appurtenances in the private property shall be tested at 1380 Kpa (200 psi) for two hours as per NFPA 24. All compression fittings used on the fire line shall be rated for minimum of 200 psi.			
30.28.02	Leakage tests for Polyethylene Pipe shall be as per OPSS.			441.07.24.02
30.28.03	Leakage tests for other pipes shall be as per OPSS.			441.07.24.03
30.29	CHARGING NEW SERVICES Any new services inside private property lines shall be commissioned initially by WUC personnel after testing. All new Services to commercial properties shall have a temporary or permanent back flow prevention device installed before water can be turned on as per WUC By Law.			
30.30	OPERATING WATER VALVES AND HYDRANTS IN CITY ROW			
30.30.01	Only WUC personnel can operate water valves or hydrants in public ROW. The valves at property lines belong to WUC.			
30.31	OPERATING WATER VALVES AND HYDRANTS ON PRIVATE PROPERTY			
30.31.01	Contractor can operate water valves on private property. The hydrants can be operated only by the Fire Department or WUC approved hydrant maintenance Contractors.			



SPECIFICATIONS FOR THE INSTALLATION OF WATERMAINS AND SERVICES

ITEM NO	WUC SPECIFICATION -CONSTRUCTION	WUC STD. DRAWINGS	CITY OF WINDSOR SPECIFICATION	OPSS STANDARD
30.32	CONNECTIONS TO EXISTING WATERMAINS IN ROW			
30.32.01	<p>Taps and Tie-ins into existing watermains shall be installed by the Contractor in the presence of Water Distribution Operators only. The Contractor must notify the WUC area supervisor at least 48 hours prior to the watermain(s) shutdown required to facilitate the tie-in procedure. Proper tools and equipment, safety restraints and personal protective equipment must be used at all times.</p> <p>Tie-in connection to the existing distribution system must be performed after the new constructed water system has successfully passed all required testing procedures (sample, pressure and leakage testing). Water Distribution Operators MUST be present during all tie-in operations.</p> <p>All materials and equipment that will be used for the tie-in must be on site 24 hours prior to the start of the watermain tie-in procedure. The materials and equipment must be inspected by the WUC Inspector for conformance with the WUC "Design Guidelines and Specifications".</p> <p>The Contractor must provide the WUC Inspector a list of personnel (by trade, not necessarily by name) who will be performing the watermain tie-in and provide verification (course certificate) that the persons performing the tie-ins have attended the mandatory WUC tie-in training session.</p> <p>The WUC Inspector has the authority to reject defective and/or improper materials and to suspend any work that is being improperly done, as well as suspend work as a result of the lack of trained personnel on site or insufficient material on site to complete all phases of the tie-in (including: steel beams, blocking, backfill material, properly displayed disinfecting products, etc.). This is subject to the final decision of the Director, Engineering.</p>			
30.32.01 (Cont'd)	<p>Under no circumstances shall the Contractor manipulate (open or close) valves in the distribution system. Operation of any components of the distribution system is performed at all times, by Water Distribution Operators ONLY.</p> <p>Watermain(s) tie-ins after hours or on weekends are to be avoided whenever possible and any overtime costs are to be paid by the Contractor requesting such work. It is at the WUC Director, Engineering discretion to approve after hours or weekend work.</p> <p>Before excavation begins, ensure all locates have been secured for the dig site, ensure all water pumps are in place, primed, full of fuel and with suction and discharge hoses connected and in place. Extreme caution must be used while excavating to avoid damage to the new and existing main. The excavated work area must be properly shored and/or sloped to ensure that personnel can perform the tie-in safely. Refer to the Occupational Health and Safety Act for details.</p> <p>The excavation should be one (1) foot below the bottom of the watermain with a two (2) foot deep sump pit at one end to allow for a pump to dewater the excavation.</p> <p>All materials, equipment and tools used in the tie-in process, along with as much as possible of the inside and outside of the new existing system, MUST be swabbed and disinfected with a minimum 50/50 sodium hypochlorite/potable water solution to minimize any possibility of contamination. Fittings are to be sprayed and wiped down. Clean swabs soaked in disinfection solution are to pass through new tie in pipes and fittings. Tools and equipment that are dedicated for usage on drinking water systems are to be properly disinfected.</p>			



SPECIFICATIONS FOR THE INSTALLATION OF WATERMANS AND SERVICES

ITEM NO	WUC SPECIFICATION -CONSTRUCTION	WUC STD. DRAWINGS	CITY OF WINDSOR SPECIFICATION	OPSS STANDARD
30.32.01 (Cont'd)	<p><u>Dewatering</u> Trench / excavation must be constructed such that it provides an adequately sized sump point for the pump suction lines.</p> <p>A minimum of two pumps to be on site. The pumps size and number must be adequate to deal with conditions and watermain sizes. Gas operated pumps to be fueled and in good operating condition. If electric pumps are to be utilized an adequately sized and fueled generator in good operating condition must be available.</p> <p>Ground water conditions may warrant additional pumps or well point installations.</p> <p>Contractor is responsible to ensure that: Pump performance is adequate to manage ground water conditions combined with the discharge or the watermain being dewatered prior to the tie-in connection. Required available refill fuel is on site. Established pumping scenario and pump capacity must absolutely ensure that the trench water level can be managed well below the invert of the watermain to be connected to.</p> <p>Consequences of improper dewatering: Contamination of the new and existing live watermains. Requirement for instituting a Boil Water Advisory. Potential for negative impacts to public health. Possible Ministry of Environment fines. Financial consequences to the contractor may include but not limited to required resources for watermain flushing, sampling. Project down time, Ministry fines, and litigation as may result due to loss of service.</p> <p><u>Tie-in Connections</u> Prior to beginning the connection ensure conditions permit the connection as identified in contract drawings and specifications. Any required deviation from the contract drawings and specifications requires consultation and approval of the WUC Engineering Department. Formalization and issuance of a contract change order. Confirmation that materials on site will meet any potential connection modifications.</p> <p>Confirm pumping set up is operating and adequate. Ground water conditions are being managed. Anticipated additional flows from existing main can be managed.</p> <p>Existing watermain is shutdown and depressurized. Valve shutdown by Water Distribution Operators. Existing watermain pipe material is confirmed. Pipe outside diameter is taken and recorded. Materials and fittings on site must meet connection needs. Pipe, fittings, valves, and tools have been disinfected.</p> <p>Prepare mark and measure the required cut lay length for the installation of the new connection. Pre-assemble the fitting with pipe sections and required restraint glands. Disinfect this prepared fitting.</p>			



SPECIFICATIONS FOR THE INSTALLATION OF WATERMANS AND SERVICES

ITEM NO	WUC SPECIFICATION -CONSTRUCTION	WUC STD. DRAWINGS	CITY OF WINDSOR SPECIFICATION	OPSS STANDARD
30.32.01 (Cont'd)	<p>Initiate the first cut to the existing main. Once the cut is complete allow the main to drain and monitor trench water levels. It is critical at this point that pumping capacity continues to manage water levels well below the invert of the existing piping. No further actions at this time until existing main has drained.</p> <p>Do not allow the discharged / ground water to come in contact with the inside of any new or existing piping to prevent generating a Category 3 situation. The contractor is responsible for all additional costs if a Category 3 situation occurs.</p> <p>Begin dewatering the isolated section of the existing watermain. The rate of dewatering should not exceed the pumping capacity. Ensure that the pumps can keep up with the inflow of water.</p> <p>The WUC representative must receive immediate notification in the event the existing watermain is subjected to contamination due to inadequate dewatering.</p> <p>With both new and existing sections of the watermains isolated and dewatered, ensure the exposed piping is disinfected and clean to minimize potential contamination from the surrounding environment.</p> <p>Complete the second pipe cut and remove the required section of existing piping. Clean and disinfect the cut ends of the existing watermain. Prepare, disinfect and install the fittings necessary to complete the connection with required restraining devices. Utilize the designated water system disinfected tools to complete torquing of all required gland flanges and restraints.</p> <p>The old watermain shall be properly capped, blocked and restrained and all new watermains shall be blocked, supported and restrained before the watermain is turned on. Refer to WUC standard drawings for details.</p> <p>If the watermain is cast iron or ductile iron, anodes are to be cad-welded to all the exposed sections of pipe. Water Distribution operators will operate Drinking Water System components, flush the new and existing watermain and verify that the connections are leak tight.</p> <p>Once the above noted operations are completed and approved, Water Distribution Operator will take digital photos and as-built measurements of the tie-in prior to backfill.</p> <p>Trench backfill and site clean up per WUC specifications.</p>			
30.33	CONNECTIONS TO NEW WATERMANS IN CITY ROW			
30.33.01	Taps from 25mm to 50 mm on a new water main may be installed by contractor in the presence of licensed WUC operator.			
30.33.02	Taps or tie-ins larger than 100mm on a new watermain may be installed by an approved Contractor in the presence of a licensed WUC operator.			
30.34	CONNECTIONS OR REPAIRS TO EXISTING SERVICE MAINS ON PRIVATE PROPERTY			
30.34.01	Contractor can work on existing water services inside private property in the presence of licensed WUC personnel.			
30.35	REPAIRS TO EXISTING WATERMANS AND SERVICES DAMAGED DURING CONSTRUCTION			
30.35.01	Damages to existing watermains and services may be repaired by an approved Contractor in the presence of licensed WUC personnel.			
30.36	TEMPORARY WATERMANS, SERVICES AND HYDRANTS			
30.36.01	WUC may install temporary watermains and services in some special projects. Refer to specific details on the tender documents.			441.07.12.01 441.07.12.02 441.07.12.03 441.07.12.04
30.37	TEMPORARY WATER SERVICES IN SPECIAL CASES			
30.37.01	Under special circumstances WUC may install a temporary water service to a single dwelling by connecting it to adjacent dwelling for a very short time using disinfected plastic pipes.			



SPECIFICATIONS FOR THE INSTALLATION OF WATERMANS AND SERVICES

ITEM NO	WUC SPECIFICATION -CONSTRUCTION	WUC STD. DRAWINGS	CITY OF WINDSOR SPECIFICATION	OPSS STANDARD
30.38	CLOSED CIRCUIT TELEVISION INSPECTION OF PIPELINES			
30.38.01	Normally WUC does not allow any closed circuit television of watermain pipe lines. Under very unusual circumstances this may be allowed under special rules dictated at that time.			
30.39	SEWER PIPE INSTALLATION IN OPEN CUT			
30.39.01	Normally WUC does not install any sewer pipe lines as part of watermain installation other than repairs to damaged system. Under unusual circumstances if any sewer pipes are to be installed, it will be to the City standards. Approval from City Engineer shall be obtained.		S-1 SS 3.2	
30.40	INSTALLATION OF CULVERTS FOR HYDRANT ACCESS			
30.40.01	Culvert shall be installed when a hydrant is installed on the back side of a ditch. Culvert installation and sizing shall be as per city of Windsor Specifications. On some WUC projects WUC may recommend the size and installation procedures.		S-1 SS 3.2	
30.41	REPAIR AND/OR INSTALLATION OF SEWERS, SEWER CONNECTIONS, CATCH BASIN LEADS AND CULVERTS			
30.41.01	As per City of Windsor Specifications.		S-1 SS 5.3.2	
30.41.02	Contractor shall make sure that the broken sewers are capped temporarily or sewage diverted away from the watermain pipes or services to prevent any contamination.			
30.42	ADJUSTING OR REBUILDING MAINTENANCE HOLES, CATCH BASINS, DITCH INLETS AND VALVE CHAMBERS			
30.42.01	As per City of Windsor Specifications and Drawings.		S-1 Sec SS 3.5.7 City Std Drawings.	
30.43	RELOCATION OF CATCH BASIN, ETC.			
30.43.01	As per City Specifications and Drawings except as stated below. Contractor to protect all catch basins (ie. Filter cloth) Any catch basins not protected will be vacuumed out by the City at the Contractors expense.		S-1 Sec SS 3.5.1 to 3.5.6 City Std Drawings.	
30.43.02	Wherever required on the drawings, the Contractor shall furnish all labour and material necessary to move, reconstruct or rebuild catch basins, manholes, connecting pipes, sewers, etc. The tender price quoted shall include prices for all excavation, backfilling, tapping existing sewers, furnishing and laying of all pipes, catch basins or other materials. Reinstatement of pavements, temporary pavements, and furnishing and placing of granular backfill and crushed stone will be paid for in addition to the quoted price for relocating catch basins and associated works.		S-38	
30.44	CONCRETE WORK			
30.44.01	As per City of Windsor Specification.		S-9	
30.45	ADJUST WATER VALVE BOXES AND CURB BOXES			
30.45.01	Contractor shall be responsible for adjusting the (existing or new) curb boxes and valve boxes in the right position before final grading, surface restoration or permanent paving is to be done. WUC shall be called upon to locate and inspect any adjustments.			
30.46	COLD MIX ASPHALT SHALL BE AS PER OPSS			309
30.46.01	Stockpiling of Patching Materials as OPSS.			307



SPECIFICATIONS FOR THE INSTALLATION OF WATERMANS AND SERVICES

ITEM NO	WUC SPECIFICATION -CONSTRUCTION	WUC STD. DRAWINGS	CITY OF WINDSOR SPECIFICATION	OPSS STANDARD
30.47	UNTREATED GRANULAR, SUB BASE, BASE, SURFACE, SHOULDER AND STOCKPILING			
30.47.01	Construction of shoulders and granular surfaced roads and driveways shall be as per OPSS. All granular materials shall be to City Specifications.		S-4	314 1004 1010
30.48	GRANULAR MATERIAL		supplementary Specs.Sec. 25 (2008)	
30.48.01	deleted			
30.48.02	Granular A material shall be as per City Specifications.		S-4	1010-Table 2
30.48.03	Granular B or C materials shall be as per City Specifications.			1010-Table 2
30.48.04	Clear Stones (Open Graded Drainage Layer)			1004-table 2
30.48.05	City of Windsor sewer stones as per City Specifications.			1004-table 2
30.49	RECLAIMED MATERIAL NOT ALLOWED ON W.U.C JOBS UNLESS APPROVED BY W.U.C. ENGINEERING.			
30.49.01	Reclaimed material not allowed on W.U.C jobs unless approved by W.U.C. Engineering. Reclaimed materials may be allowed on some City of Windsor projects as fill material. Contractor is responsible for getting the necessary approval from the City.			
30.50	RESTORING UNPAVED AND ROADWAY SURFACES			301
30.51	ASPHALT CURB AND GUTTER SYSTEMS			
30.51.01	Not to be used unless approved by W.U.C. Engineering			312
30.52	CONCRETE CURB AND GUTTER SYSTEMS		S-5 AS 208 AS 216	
30.53	HOT MIX ASPHALT PAVEMENT FOR ROADWAYS, DRIVEWAYS AND SIDEWALKS		S-10 AS 214 AS 203 AS 221	311 310 1150
30.53.01	HL type (hot laid) and thickness shall be as per approved drawings or city specs.			
30.54	CONCRETE PAVEMENT AND CONCRETE BASE FOR ROADWAYS, DRIVEWAYS, AND SIDEWALKS.		S-6, S-7,S-8 & S-9 AS 204 AS 210 AS 211 AS 212 AS 222 AS 225 AS 401	
30.54.01	Concrete Sidewalk - Residential		S-6 & SUP SPEC 21 AS-401	
30.54.02	Concrete Sidewalk - Commercial		S-6 AS 403	
30.54.03	Concrete Wheel Chair Ramps - Residential		S-6 AS 402	
30.54.04	Concrete Wheel Chair Ramps -Commercial		S-6 AS 404	



SPECIFICATIONS FOR THE INSTALLATION OF WATERMANS AND SERVICES

ITEM NO	WUC SPECIFICATION -CONSTRUCTION	WUC STD. DRAWINGS	CITY OF WINDSOR SPECIFICATION	OPSS STANDARD
30.55	INSTALLATION OF INTERLOCKING CONCRETE PAVERS/BRICKS OR OTHERS			
30.55.01	The Contractor shall carefully remove existing interlocking paving stones in areas affected by watermain installation. These paving stones are to be stored and re-installed after watermain installation. All work to be performed by personnel experienced in this field, and in a workmanship manner so that the appearance on completion shall be as near as possible to the original. Any paving stones damaged shall be replaced at the Contractor's expense. Installation shall be as per OPSS 355.			355
30.56	RESTORATION /REPAIR OF CONCRETE PAVEMENT		AS 207A	360
30.57	RESTORATION OF CONCRETE BASE WITH ASPHALT PAVEMENT		AS 207C	
30.58	RESTORATION OF FULL DEPTH ASPHALT PAVEMENT		AS 207B	
30.59	SITE RESTORATION OTHER THAN ROADS AND SIDEWALKS			
30.59.01	General All disturbed areas shall be restored to an equivalent or better condition than existed prior to the commencement of construction.		S-14, S-34	
30.59.02	Grading		S-14, S-34	507.07.02
30.59.03	Fences and Guide Rails			507.07.04
30.59.04	Topsoil		S-14, S-34	
30.59.05	Shrub and Tree Replanting			507.07.06
30.59.06	Sodding		S-14 and AS 205	
30.59.07	Seeding and Mulching		S15	
30.59.08	Reusing Existing Lawn In lawn areas where the type of existing sod cannot be matched with readily available local sod (i.e. creeping bent, etc.), the contractor will be required to carefully remove the existing "special" sod from all areas affected by new watermain installation, maintain and replace the same sod after new watermain installation has been completed.			
30.60	CLEANLINESS			
30.60.01	Dust Control Dust control measures shall be taken on a continuous basis as required.		S-37	
30.60.02	The Contractor shall be required to grade the trenches daily and remove any excess material from the jobsite as required. Mud tracked into travelled roadways shall be removed immediately. The job site shall be left in a safe condition prior to leaving the job site for the day. Stockpiles of material, granular and construction equipment shall be well marked and secured. The job site shall be kept clean and free of unnecessary debris. All watermain related unnecessary pipe and debris shall be picked up and removed . As the backfilling of the trench progresses, the boulevards, pavements and sidewalks shall be thoroughly cleaned and all surplus material removed there-from. Upon completion of the work and before acceptance of the same, the site of the work shall be left in the same condition that existed before the work started. All sodded areas shall be resodded and all private property left in perfect repair.			



SPECIFICATIONS FOR THE INSTALLATION OF WATERMANS AND SERVICES

ITEM NO	WUC SPECIFICATION -CONSTRUCTION	WUC STD. DRAWINGS	CITY OF WINDSOR SPECIFICATION	OPSS STANDARD
30.61	TRAFFIC CONTROL SIGNAGE			
	Traffic Control SignAGE as per MTO Book 7 and shall be approved by City of Windsor Traffic department.			
30.62	SITE OFFICE			
30.62.01	If requested by WUC, a site office shall be installed. This work consists of all material, equipment and labour required to supply, erect, maintain and remove a field office on the site for the sole use of the Engineer and his representatives for the duration of the contract. The office shall be 150 ft. square minimum area and will be provided with electricity, telephone, heat, hand cleaner and paper towels, and a supply of portable drinking water with disposable cups. The Field Office shall also be equipped with one (1) office desk and six (6) office chairs. Open parking space for at least three (3) cars shall be located convenient to the office. The Contractor shall bear all expenses in connection with the office, including the monthly service charges for lighting, cellular telephone, water and heating costs and land rental costs, if applicable. Long distance calls will not be the responsibility of the Contractor.			
30.62.02	Site Office - Measurement & payment Measurement - Will be made on a Lump Sum basis. Payment - Will be made at the Unit Price Bid and shall be compensation in full for all labour, equipment and material required to complete the work specified herein.			
30.63	TOILET FACILITIES			
30.63.01	The Contractor shall furnish toilet facilities on the job site. Each facility shall be equipped with: i) A toilet that has a toilet seat and cover. ii) A urinal trough in addition to the toilet, if the toilet facilities are portable or temporary. iii) Toilet paper and disinfectant. iv) Measurement will be made on a Lump Sum basis. v) Payment will be made at the Unit Price Bid and shall be compensation in full for all labour, equipment and material required to complete the work specified herein.			
30.64	CATHODIC PROTECTION OF EXISTING WATERMANS	50.13.01 to 50.13.04		OPSS 702



WINDSOR UTILITIES COMMISSION WATER DIVISION CITY OF WINDSOR

DESIGN GUIDELINES AND SPECIFICATIONS FOR THE INSTALLATION OF WATER MAINS AND SERVICES

PART 40 APPROVED MATERIAL LISTINGS

Revisions

- Dec 2024 - 40.05.06 - Added Georg Fischer Multi Joint 3000
- Dec 2024 - 40.20.02 - Added King Inn. DryConn IDC Connector 98405
- Dec 2024 - 40.22.01 - Added note "Upper valve section..."
- Dec 2024 - 40.22.07 - Added section & notes
- Dec 2024 - 40.23.02.01 - Separated Bolts & Rods. Added notes
- Dec 2024 - 40.24.01 - Added AY McDonald 76100Q
- Dec 2024 - 40.24.02 - Added AY McDonald 74701BQ
- Dec 2024 - 40.24.03 - Added AY McDonald 74758Q
- Dec 2024 - 40.25.03 - Added HydrantTech Fabricated Single Meter Pit
- Dec 2024 - 40.25.03 - Added HydrantTech Fabricated Dual Meter Pit
- Dec 2024 - 40.25.05 - Added Ford W3
- Dec 2024 - 40.25.05 - Added AY McDonald 74M3W
- Dec 2024 - 40.25.05 - Added Domcast DFWV11
- Dec 2024 - 40.25.05 - Added Mueller 780069
- Dec 2024 - 40.25.05 - Added Mueller 693H10811

- Dec 2023 – remove Cobra Lock pipe from 40.01.01
- Dec 2023 – add AY McDonald setters from 5/8" – 2" in 40.25.06
- Dec 2023 – revise Cambridge Brass 1.5" and 2" setters in 40.25.06



APPROVED MATERIAL LISTING FOR NEW WATER MAIN INSTALLATION TABLE OF CONTENTS

40.01	PIPE-----	1
40.02	SERVICE PIPING-----	2
40.03	D.I. STAND PIPES-----	2
40.04	FOAM SWABS- HIGH DENSITY-----	2
40.05	FITTINGS-----	2
40.06	THRUST BLOCKS- CONCRETE-----	4
40.07	THRUST RESTRAINING DEVICES (MECHANICAL)-----	4
40.08	GLAND RINGS FOR MJ/DISMANTLING JOINTS/FLANGE ADAPTERS-----	5
40.09	HYDRANTS-----	6
40.10	VALVES-----	7
40.11	BUTTERFLY VALVES-----	9
40.12	AIR REALEASE VALVES-----	10
40.13	BACKFLOW PREVENTERS-----	10
40.14	TAPPING SLEEVES & SERVICE SADDLES-----	10
40.15	GASKETS-----	12
40.16	BLOW-OFF-----	12
40.17	GROUNDING-----	13
40.18	CATHODIC PROTECTION-----	13
40.19	INSULATION-----	14
40.20	TRACER WIRE & APPURTENANCES-----	14
40.21	CURB BOXES-----	15
40.22	VALVE BOXES-----	15
40.23	FASTENERS-----	16
40.24	WATER SERVICE MATERIALS-----	16
40.25	METER PITS-----	18
40.26	MISCELLANEOUS-----	19
40.FM.01	FOR FIRE MAINS-----	19



**WINDSOR UTILITIES COMMISSION
APPROVED MATERIAL LISTING FOR NEW WATER MAIN INSTALLATION**

ITEM	PRODUCT	SPECIFICATION	MANUFACTURER	DESCRIPTION / MODEL NO.
40.01	PIPE			
40.01.01	PVC Pipe 100mm to 300mm dia (4" to 12" dia.)	PVC Class 150 DR-18 (pressure rated 235 psi) AWWA C-900, CSA-B137.3 Capped at Factory, Blue in Colour	WESTLAKE (NAPCO) (ROYAL)	ROYAL CIOD PRESSURE PIPE
			DIAMOND	C900:PVC PRESSURE PIPE
			IPEX	BLUE BRUTE
				FUSIBLE BRUTE
				TERRABRUTE
NEXT PIPE	AQUALOC			
40.01.02	PVCo 100mm TO 750mm (4" TO 30")	AWWA C-909 CSA-B137.3 BIAXIALLY ORIENTED PVC Capped at Factory, Blue in Colour	IPEX	BIONAX
			WESTLAKE (NAPCO) (ROYAL)	GASKETED INTEGRAL BELL (IB)
40.01.03	PVC Pipe 350mm to 400mm dia. (14" to 16" dia.)	PVC DR-18 (Pressure rated 235psi) AWWA-C905, CSA-B137.3 Capped at Factory, Blue in Colour	IPEX	CENTURION FUSIBLE BRUTE
			WESTLAKE (ROYAL)	ROYAL CIOD PRESSURE PIPE
			DIAMOND	TRANS-21 C905
40.01.05	Concrete Pipe 350mm to 500mm dia. (14" to 20" dia.)	Concrete Pressure Pipe AWWA C-303 min class 14 or as approved by WUC	FORTERRA	PRESCON
			MONRO	CONCRETE PRESSURE PIPE
40.01.06	Concrete Pipe (600mm to 2700mm dia.) (24" to 106")	Concrete Pressure Pipe AWWA C-301	FORTERRA	CONCRETE PRESSURE PIPE
			MONRO	CONCRETE PRESSURE PIPE
40.01.07	High Density Polyethylene pipe 100mm to 1575mm (4" to 63")	High Density Polyethylene DR11 (Ductile Iron Pipe Size DIPS) (pressure rating of 160 psi) AWWA C-906	PERFORMANCE PIPE	DRISCOPEX 4000
			KWH	SCLAIRPIPE
40.01.08	Pipe End Caps	OPSS 441.07.07. Tamper evident seals to display manufacturer or logo.		

40.02	SERVICE PIPING			
40.02.01	COPPER 19mm to 50mm dia. (3/4" to 2" dia.)	Copper tubing AWWA C-800 Certified ASTM B88-49 Type "K" soft copper	GREAT LAKES COPPER CERRO	 CERROTUBE
40.02.02	CROSSLINKED POLYETHYLENE PEX 25mm to 50mm dia. (1" to 2" dia.)	Copper Tube sizes (CTS) OD (SDR 9) AWWA C-904 CSA B137.5	IPEX REHAU	BLUE904 MUNICIPEX
40.02.03	POLYETHYLENE RAISED TEMPERATURE 25mm to 50mm dia. (1" to 2" dia.)	Polyethylene Class 160 (CTS) OD (SDR 9) AWWA C-901 CSA B137.18	AQUAPURE	PE-RT PE445574A
40.02.04	<i>Service Piping -75 mm dia. (3" dia.) (Not approved yet)</i>	High Density Polyethylene DR 11(Ductile Iron Pipe Size) certified to series 160 (pressure rating of 160 psi) AWWA C-901		only used inside private property beyond the control valve. Not approved yet.
40.03	D.I. Stand pipes	"Ductile-Iron Pipe, Centrifugally Cast for Water" ANSI/AWWA C151/A21.51		
40.04	FOAM SWABS High Density Polyurethane for Pipe Cleaning to fit 100mm thru 300mm dia. (4" to 12")			High density polyurethane for pipe cleaning to fit 4" dia. through 12" dia.
40.05	FITTINGS			
40.05.01	D.I.Bends,tees,Reducers and Crosses LONG BODY	ANSI A21.10 AWWA C153/C111 Cement Mortar lined as per ANSI A21.4(AWWA C104)	SIGMA STAR BIBBY/TYLER/UNION RCT Flex-Tite Fitting	NOTES: Furnished with push-on Tyton Joints as per ANSI A21.11 (AWWA C111) Only used for tying into existing watermains or on special approval
40.05.02	D.I.Bends, Tees, Reducers and Crosses COMPACT FITTINGS SHORT BODY	ANSI A21.10 AWWA C110 Cement Mortar lined as per ANSI A21.4 (AWWA C104)	SIGMA STAR BIBBY/TYLER/UNION	NOTES: Mechanical type ends

40.05.03	PVC Bends, Tees, Reducers and Crosses	PVC AWWA C-907 Class 150 CSA B137.2 UL Listed and FM Approved	IPEX	Blue Brute Injection-Molded PVC 100mm - 400mm (4"-16")
			HARCO	Injection-Molded PVC 100mm - 200mm (4"-8")
40.05.04	PVC Tapped Couplings 100mm to 200mm (4" to 8") by 19mm to 50mm(3/4" to 2")	PVC AWWA C-907 Class 150 CSA B137.2 AWWA Thread	IPEX	Blue Brute Tapped Coupling
			HARCO	
40.05.05	Transition Couplings (no longer approved)	To AWWA C-219 Sleeve -Ductile Iron minimum - ASTM A 536 End Rings -Ductile Iron ASTM 536 Grade 65-45-12 Bolts and Nuts Stainless steel OR Carbon Steel Exceed ASTM A 307 Epoxy coated to AWWA C-213	ONLY APPROVED UNDER EMERGENCY CONDITIONS BY WATER ENGINEERING	
40.05.05A	2 Bolt Coupling	To AWWA C-219 Epoxy coated to AWWA C-213 Stainless steel or Carbon steel exceed ASTM C-213 304 Stainless steel bolts and nuts	SMITH-BLAIR	Series 421
			ROBAR	1696-2B
			HYMAX	Hymax 2
			ROMAC	Macro HP
40.05.06	Flanged Couplings	To AWWA C-219 Sleeve -Ductile Iron or carbon steel Minimum - ASTM A 536 End Rings -Ductile Iron ASTM 536 Grade 65-45-12 Bolts and Nuts, Stainless Steel or Carbon Steel exceed ASTM A 307 Epoxy coated to AWWA C-213	SMITH-BLAIR	Omni 912 Series (100mm to 300mm)
			ROBAR	7400 Series (100mm to 300mm)
			ROMAC	FCA501 (100mm to 400mm)
			FORD	Flex FFCA (100mm to 300mm)
			GEORG FISCHER	Multi Joint 3000 (100mm to 400mm)
40.05.07	Reducing Couplings	Sleeve -Ductile Iron Minimum - ASTM A 536 End Rings -Ductile Iron ASTM 536 Grade 65-45-12 Bolts and Nuts, Stainless Steel or Carbon Steel exceed ASTM A 307 Epoxy coated to AWWA C-550	FORD	Flex FRC
			SMITH-BLAIR	415
			ROBAR	1506R & 1508R
			ROMAC	RC501 & RC400
			GEORG FISCHER	Multi Joint 3000 (100mm to 400mm)

40.05.08	Repair Clamps	Band -stainless steel Type 304, 18 gauge Lugs -ASTM A536 epoxy coated Gasket - Grade 60 Bridge Plate - stainless steel bolts - Stainless Steel to ASTM A325 or A242 Nuts - Type 304 Teflon coated	CAMBRIDGE BRASS	Series 425 Teck (100mm to 300mm) Series 825 Teck (350mm to 500mm)
			FORD	FS1 (100mm to 300mm) FS3 (400mm to 600mm)
			SMITH BLAIR	series 261, 262 (100mm to 300mm) series 263 (350mm to 600mm)
			ROBAR	Robar5616 (100mm to 300mm) Robar 5636 (350mm to 750mm)
			STRAUB	
			CONCORD	D76R-Series 200 (100mm to 350mm)
40.05.09	PVC Repair Coupling 100mm to 300mm (4" to 12")	AWWA C907 Injected molded PVC CSA B137.2 PVC gasketed fittings ASTM D1598	IPEX - Blue Brute Molded PVC Fittings	073404, 073406, 073408, 273529, 273530
40.06	THRUST BLOCKS concrete	OPSS 1350, 20mpa at 28 days 10mpa as per OBA		
40.07	THRUST RESTRAINING DEVICES (MECHANICAL)			
40.07.01	Thrust Restraint Device For PVC Pipe	Gland Ring to ASTM 536, Ductile Iron, Side square head clamping bolts and hex nuts to ANSI B 18.2.1 and zinc plated to ASTM A 153. Sizes compatible to AWWA C 900 & C905 PVC pipes Extra long T bolts to AWWA/ANSI C111/A21.11	FORD	Uniflange 1300C w/ mech joint/push on Uniflange 1350C for pipe bell joints Uniflange 1500C MJ retainer gland
			STAR	1000G2, 4000, & 4000G2 MJ fittings only 1100G2 for pipe bell joints 1200G2 PVC fittings only 4300 series
			CLOW	Series 300 & 360 Restrainers Tyler Union TufGrip Series 1500
			SIGMA	Series PWP for pipe bell joints Series PWM MJ fittings only Series PWPF PVC fittings only ONE-LOK SLCS
			EBAA IRON	Series 1500 & 1600 for pipe bell joints Series 2000 MJ fittings only Series 2600 PVC fittings only
			40.07.02	Thrust Restraint Device for Ductile or Cast Iron Pipe

40.07.03	Thrust Restraint Device for PVCo pipe (Molecularly oriented PVC)	High Tensile Ductile Iron to ASTM A 536 T bolts and nuts to AWWA C-111 CSA B137.3.1-09 certified AWWA C909 and NSF 61 certified	SIGMA	Series PWPFC PVC fittings only Series PWP for pipe bell joints Series PWM MJ fittings only ONE-LOK SLCS
			CLOW	Series 300, 360 & 390 Restrainers
			STAR	3500PF & 1200R PVC fittings only 3500C & 1100C for pipe bell joints 3500, 1000C, & 4000G2 MJ fittings only series 4300
				FORD
			EBA IRON	Series 1900 for pipe bell joints
40.08	GLAND RINGS FOR MJ / DISMANTLING JOINTS / FLANGE ADAPTERS			
40.08.01	Dismantling Joints	Flanged adaptor body to be carbon steel per ASTM A53, ASTM A512, ASTM A283 GRC, ASTM A36. Follower flange to be ductile iron per ASTM A536, steel section per ASTM A576 GR1020HR. Finish to be fusion bonded flexi-coat epoxy. Flanges to be carbon steel per AWWA C207, Class D	Smith-Blair	Series 971, 972 and 975
40.08.02	Flange Adapters for DI pipes Size 100mm to 300mm dia. (4" to 12" dia.)	High Tensile Ductile iron to ASTM A 536. Grade 65-45-12 color code red for D.I .O.D. Gasket - EPDM Drilling-ANSI B16.1 for cast iron flange and ANSI B 16.5 for steel Flange	FORD	Uniflange Series 200 & 400
			CLOW	Series 40
40.08.03	Flange Adapters for PVC pipes Size 100mm to 300mm dia. (4" to 12")	High Tensile Ductile iron to ASTM A 536. Grade 65-45-12 color code red for D.I .O.D. Gasket - EPDM Drilling-ANSI B16.1 for cast iron flange and ANSI B 16.5 for steel Flange	FORD	Uniflange Series 900
			CLOW	Series 90-C

40.08.04	MJ Gland Rings For MJ Fittings Sizes 100mm to 300mm dia. (4" to 12" dia.)	Ductile Iron to ASTM A 536 pressure rated same as the pipe rating Asphaltic coating manufactures identity stamped or casted as per AWWA C 111 & C153	BIBBY/TYLER/UNION	D011 to D014
			SIGMA	FMC9149 TO 9152
			STAR	MJG06, MJG08, MJG10, MJG12
40.09	HYDRANTS			
40.09.01	Hydrants	AWWA C-502 3-Way Dry Barrel Type Barrel - Two piece with Break away Safety Flange operating nut- CSA 1.5"(37mm) Square open to the left (Counter clockwise) Externally Plugged. 2- 65(2.5")mm hose connection / 5 threads per inch as per CSA standards. OD thread 3" - I.D. opening 2 1/2") V thread 3/32" deep 1- 4" Pumper connection 6 threads per inch as per CSA standard (O.D. thread 4 5/8" - I.D. Opening 3 3/4") V thread 3/32" deep. 6" M.J.Shoe 1650mm in bury length unless stated otherwise Exterior above ground - One coat neutral Orange Rust inhibitive Primer and one coat quick dry brushing enamel - Yellow in Colour Ductile under- Ground portion of Hydrant shall be coated with Bitumen. Type 316 Stainless Steel Nuts and Bolts on boot Assembly All interior epoxy coated. Use food grade lubricant on hydrants only.	CLOW CANADA	McAvity Brigadier M67B
			EJ	74585D
			MUELLER CANADA / CANADA VALVE	Century & Darling B-50 & B-18

40.10	VALVES			
40.10.01	Gate Valves non rising stem 100mm to 300mm (4" to 12") dia	AWWA C-509 & C-515 Red Operating Nut, open clockwise pressure rated to minimum of 200psi Non rising stem Epoxy coated inside and out to C-550 Fully Encapsulated Resilient Wedge No push on joints for 200mm (8") and 300mm (12")	CLOW	C.I. MODEL 2640 D.I. MODEL 2638
			MUELLER	SERIES A-2361
			EJ	22022, 22032, 33042, 22052, 22062
			AVK	SERIES 45 (FULL WALL) SERIES 65 (REDUCED WALL)
			J & S VALVE	SERIES 6900, 6800, 6600, 6500
40.10.02	Gate Valves non rising stem > 300mm (> 12")	AWWA C-509 & C-515 Red Operating Nut, open clockwise pressure rated to minimum of 200psi Non rising stem Epoxy coated inside and out to C-550 Fully Encapsulated Resilient Wedge no push on joints > 400mm requires prior Water Engineering Approval	CLOW	C.I. MODEL 2640 D.I. MODEL 2638
			MUELLER	SERIES A-2361
			EJ	22072, 22082, 22092
			AVK	SERIES 45 (FULL WALL) SERIES 65 (REDUCED WALL)
			J & S VALVE	SERIES 6900, 6800, 6600, 6500
40.10.03	Gate Valves Outside Screw and Yoke (OS&Y) 100mm to 300mm (4" to 12")	AWWA C-509 & C-515 Red Operating Nut open left pressure rated to minimum of 200psi Epoxy coated inside and out to C-550 Fully Encapsulated Resilient Wedge Rising stem (OS&Y) type	CLOW	C.I. MODEL 2640 D.I. MODEL 2638 (REDUCED WALL)
			MUELLER	SERIES R-2365
			AVK	SERIES 45 (FULL WALL) SERIES 65 (REDUCED WALL)
			J & S VALVE	SERIES 6700
			40.10.04	Post Indicator valves
AVK	SERIES 34			
MUELLER	SERIES P-2361			

40.10.05	Tapping Valves 100mm to 300mm (4" to 12")	2" sq. Red Operating Nut pressure rated to minimum of 200psi opening clockwise, one end mechanical unless specified as flanged Non Rising Stem Bronze stem Resilient Seat, complete with paper Gasket, fully encapsulated wedge with Elastometer minimum 8 mm thick Epoxy coated inside only C/W 8 - 3/4" X 4" UNC Type 316 S/Steel Hex Head Nuts & Bolts To meet A.W.W.A Specification C-509, C-515 & C-550	MUELLER	SERIES A-2361
			AVK	SERIES 45 (FULL WALL) SERIES 65 (REDUCED WALL)
			CLOW	C.I. MODEL 2640 D.I. MODEL 2638
			J & S VALVE	SERIES 6800
			EJ	SERIES 25000
40.10.06	Tapping Valves 400mm to 600mm Dia. (16" dia to 24" dia.)	2" sq. Red Operating Nut opening clockwise one end mechanical unless specified as flanged Non Rising stem Bronze stem Resilient Seat, complete with paper Gasket fully encapsulated wedge with Elastometer minimum 8 mm thick Epoxy coated inside only C/W 8 - 3/4" X 4" UNC Type 316 S/Steel Hex Head Nuts & Bolts to meet A.W.W.A specification C-509, C-515 & C-550	REQUIRES prior approval from WUC	

40.11	BUTTERFLY VALVES			
40.11.01	Butterfly Valves 400mm to 1800mm (16" to 72")	<p>For Underground service Red operating nut - Open clockwise, rated min 150 psi 1. AWWA C504, Class 150-B latest revision and NSF approved. 2. Suitable for Direct Burial Service. 3. Iron body to ASTM A-126 Class B. 4. Short body Flanged ends to ANSI B16.1 CLASS 125.or M.J.Joints as per AWWA C- 153 AND C-110 & C-111 5. Ductile Iron Disc with flow through design. 6. EPDM Resilient seat with Stainless steel retaining ring and fasteners. 7. Valve body seat shall be stainless steel. 8. Valve shafts to be Stainless Steel with adjustable stem packing. 9. Geared Actuators, totally enclosed cast iron epoxy coated housing with stainless steel nuts and bolts, gasketed water and vapour tight cover, hardened steel worm and bronze worm gear assembly with 50mm (2") square operating nut. 10. Entire valve body (inside and out) including disc and gear actuator shall be finished with 2 coats of non-toxic epoxy paint for potable water use complying with AWWA C550 and NSF61. 11. All exposed fasteners including gear actuator to be stainless steel. 12. Rubber seated</p>	CLOW	M&H style 4500 & 1450
			MUELLER	Lineaseal III (Class 150B)

40.12	AIR RELEASE VALVES			
40.12.01	Air Release Valves	Tested and manufactured per AWWA C512 and certified to NSF/ANSI 61	VAL-MATIC FEBCO CRISPIN	201C, 202C, 203C Threaded UL Series
40.13	BACKFLOW PREVENTERS			
40.13.01	Double Check Valve Assembly (DCVA) Backflow Preventer	CSA B-64 approved Can be installed on existing conditions if not a high hazard level per CSA standards	WATTS WILKENS FEBCO	
40.13.02	Reduced Pressure Backflow Preventer (RP)	Reduced pressure principle back flow preventer to CSA B-64.4.1 for new installation on domestic services.	WATTS WILKENS FEBCO	
40.13.03	Double Check Detector Assembly (DCDA)		WATTS WILKENS FEBCO	
40.14	TAPPING SLEEVES & SERVICE SADDLES			
40.14.01	Service Saddles	Saddle Clamp, Single Band, 2-Bolt Stainless Steel, 18 gauge AWWA Tapper Outlet, Stainless Steel Nuts and Bolts, Fluorocarbon Teflon coated. 19mm to 50mm (1" to 2") Belleville Washers required on all saddles	CAMBRIDGE BRASS SMITH-BLAIR ROBAR	TECK 8403-BW, TECK 8410, 8413, 8415 SERIES 370 2616

40.14.02	Tapping Sleeves for PVC and Iron Mains 100mm 300mm(4" to 12")	Pressure rated to 175 psi, min test pressure of 200psi Body, Lugs and neck: Full circumference band 18-8 Type 304 Stainless steel, 18 gauge Flange as per AWWA C-207 class D 18-8 Type 304 Stainless Steel, Stainless steel studs and nuts 18-8 Type 304 with Type 304 stainless steel and Nylon Washers- Fluorocarbon / Teflon Coated 19mm (3/4") NPT bronze test plug with square head. Nitrile Gaskets	FORD	Fast Series
			ROBAR	6606
			ROMAC	SST
			SMITH-BLAIR	663
			POWERSEAL	3480AS
40.14.03	Tapping Sleeves for PVC and Iron Pipes : 400mm to 600mm (16" to 24"dia).	Pressure rated to 100-150 psi, 18-8 Type 304 Stainless steel, 18 gauge Flange as per AWWA C-207 class D 18-8 Type 304 Stainless Steel, Stainless steel studs and nuts 18-8 Type 304 with Type 304 stainless steel and Nylon Washers- Fluorocarbon / Teflon Coated 19mm (3/4") NPT bronze test plug with square head Nitrile Gaskets		REQUIRES PRIOR WUC approval
40.14.04	Tapping Sleeve for Concrete pressure pipes. Outlet greater than 100mm - Strap Type	Body - ASTM 283 Gr. C or Mild steel plate ASTM A36 Flange AWWA C 207 Class D ANSI 150 or MSS - SP 60 Gasket Nitrile Straps Type 304 stainless steel or ASTM 36, 18 gauge Type 304 stainless steel bolts and nuts Grout Pipes ASTM A 53	HANSON SMITH-BLAIR	prior WUC and manufacturer approval needed

40.14.05	Tapping Sleeve for Concrete pressure pipes. Weld Type Outlet greater than 100mm	As per manufactures recommendation. Prior approval by WUC needed.		
40.15	GASKETS			
40.15.01	Rubber Gaskets for Push on Joints	CAN/CSA-B137.3, and have a minimum pressure rating of 1100 kPa Flexible elastomeric seals (SBR) as per ASTM D 3139. Also AWWA C-111 Sec. 4.4.4	IPEX ROYAL DIAMOND REHAU	
40.15.02	Rubber Gaskets for M.J.fittings 100mm to 1200mm (4" to 48")	SBR as per AWWA C111 Sec 4.4.4 size, mould number, manufactures mark, country, year of manufacture shall be moulded or permanently marked on the gasket.	ROL	WWW55 (204,206,208 SERIES)
			SIGMA	PTL (04,06,08,10,12 SERIES)
			STAR	MJGAS (04,06,08,10,12 SERIES)
40.15.03	Rubber Gaskets for Flanged Joints			
40.15.04	Nitrile Gaskets for special site conditions	ASTM Designation NBR, Generally resistant to hydro carbons,Fats,oils,greases,hydraulic fluids and Chemicals.		
40.16	BLOW-OFF'S			
40.16.01	50mm Valves	50mm(2") Brass Gate Valve F.I.P.T. x F.I.P.T.		
40.16.02	50mm diameter Blow off pipe	50mm(2") Galvanized Pipe 1.5m (5ft)" long M.I.P.T x M.I.P.T		
40.16.03	50mm diameter cap	50mm(2") Galvanized Cap F.I.P.T		
40.16.04	50mm diameter bend	50mm(2") Galvanized 45 or 90 ° Elbow F.I.P.T / F.I.P.T		
40.16.05	50mm Nipples	50mm(2") brass Nipples x150mm(6") Long		

40.17	GROUNDING			
40.17.01	Grounding Plate	Min size 6mmx 250mmx 400mm(1/4" x 10" x 16") galvanized plate c/w bronze grounding connector to Esc/CSA Sec. 10 -700 Connector (Brass)	THOMAS & BETTS	1016TB
			ORTECH	GP
40.17.02	Ground Clamps	19mm to 50mm (3/4" to 2") Bronze Clamps	THOMAS & BETTS	3902BU-3909BU Ground clamps JAB58H Grounding rod clamp
40.17.03	Ground Wire	#3 AWG TWU 600V Stranded Single Conductor (Services to 200 AMP)		
40.18	CATHODIC PROTECTION			
40.18.01A	ANODES 5.4 Kg (12 Lbs) Zinc	Packaged to Meet ASTM B418-73 Type 11 Purity Standards Including #10-7 Strand 5' Copper Wire with Jacket	MAPLE AGENCIES	ADZBP12
			INTERPROVINCIAL CORROSION CONTROL	ICCC: 12S14ZP
			BTI	ZA-12
			IAC	ANZ12.4
40.18.01B	ANODES 10.9 Kg (24 Lbs) Zinc	Packaged to Meet ASTM B418-73 Type 11 Purity Standards Including #8 Solid Copper Wire with Jacket - 5Ft.	INTERPROVINCIAL CORROSION CONTROL	24SI-4ZP
			CORROSION SERVICES	2448
			MAPLE AGENCIES	SP-24
			COREXCO	Cor Z-24
			BTI	ZA-24
			IAC	ANZ24.4
40.18.01C	ANODES 14.5 Kg (32 lbs) Magnesium	High Potential Magnesium Supplied with 3m. 10 AWG Copper Wire TWU 75 FT1, 600 V Black Coated Jacket	INTERPROVINCIAL CORROSION CONTROL	32D5GG- 32lb
			BTI	MA-32

40.18.02	SAC CAPS 12mm to 19mm (1/2" - 3/4") dia.	Zinc Caps 1/2" UNC 5/8" L UNC 3/4" L UNC	INTERPROVINCIAL CORROSION CONTROL	
40.18.03	Cadweld Powder Cartridge	Cadweld Connections	ERICO PRODUCTS	
40.18.04	Cathodic Protection Test Stations	Flush Mount	PRO-MARK	PM-TS5
40.18.05	Petrolatum corrosion protection systems	Prime surface completely with paste, apply profiling mastic to uneven surfaces to fill all voids, including but not limited to uneven surfaces on flanges and appurtenances, and wrap area completely with two layers of petrolatum tape.	DENSO	P1 System
			PCS	PETRO COATING SYSTEMS
			CHASE CORPORATION	CHASE PROTECTIVE COATINGS
40.19	INSULATION			
40.19.01	Rigid Foam 600mmx 2400mm x 50mm (24"x96"x2")	Expanded , Extruded Polystyrene Boards. min. R 10 and Blue in colour ASTM C 578 Type VI or ASTM C578 Type IV UL Classified or classified	DOW CHEMICAL	HI 40
			CELFORTEC INC.	FormulaR 400
40.19.02	Insulated Pipe 25mm to 600mm dia. (1" to 24" dia)	Factory applied Polyurethane Foam	URECON	Refer to Manufacture's Spec
40.20	TRACER WIRE & APPURTENANCES			
40.20.01	Tracer Wire	#12 AWG high-strength copper clad steel insulated with a 30 mil, high density polyethylene insulation, blue in colour	COPPERHEAD	1230Blue-SF Open Cut only 1245Blue-EHS Directional Drill
			PRO-LINE PRO-TRACE	HF-CCS-PE30 Open Cut Only HDD-CCS-PE45 Directional Drill
40.20.02.01	Electrical Wire Connectors (Inline & Crosses)		COPPERHEAD	Snakebite Locking Connectors
40.20.02.02	Electrical Wire Connectors (Services & Tees)		PRO-LINE	Tracer-Lock Connectors
			KING INNOVATION	DryConn IDC Connector 98405
40.20.03	Magnesium Grounding Anodes	1lb. Anode to be connected to tracer wire ends	COPPERHEAD	#ANO-1005
			PRO-LINE	PRO-TRACE GA-MG-DR-15

40.20.04	Tracer Wire Test Stations	Installed above grade behind hydrants. Two terminals with jumper 1" conduit	COPPERHEAD	Cobra T2-Blue01
			PRO-LINE	Tracerlet TLET-2T-02-FPK58
40.20.05	Insulating Mastic Tape		PLYMOUTH BISHOP	#10 Polyseal
40.21	CURB BOXES			
40.21.01	Curb Service Box	1.35m to 1.65m (4.5' to 5.5') Deep Marked "water" Brass Pentagon Plug Arch Base Type Bolt on curb box lid for tracer wire	BIBBY/TYLER/UNION STE. CROIX	VSB1 19mm-25mm (3/4"-1") VSB2 37mm-50mm (1 1/2"-2")
			MUELLER	A-726 19mm-25mm (3/4"-1") A-728 37mm-50mm (1 1/2"-2")
			DOMCAST	DF9007
40.21.02	Stainless Steel Rod For Curb Service Box	304 Stainless Steel Rod SCH 40 900mm (36") Long Top of the Rod Shaped 25mm Wide x 6.5mm Thick (1" x 1/4")	BIBBY/TYLER/UNION STE. CROIX	
			MUELLER	
			DOMCAST	
40.21.03	Stainless Steel Cotter Pin	304 Stainless Steel		
40.21.04	Service Box Repair Cover	Marked "water" 3/8" Set Screw - Unthreaded 1" Pipe	MUELLER	165
40.22	VALVE BOXES			
40.22.01	Upper Section	OPSS 1850 - Cast Iron to ASTM A48 or ASTM A 536 130mm (5 1/4") dia x 700mm (28" Screw Type) Upper valve box section shall include internal threads to receive screw-type riser.	BIBBY/STE. CROIX	VB650
			STAR	VB-5007
			DOMCAST	DF69 SERIES
40.22.02	Lower Section	OPSS 1850 Cast Iron to ASTM A48 or ASTM A 536 600mm (24")	BIBBY/STE. CROIX	VB550
			STAR	VB-0006 VBDHD
			DOMCAST	DF69 SERIES
40.22.03	Iron Cover	OPSS 1850 Cast Iron to ASTM A48 or ASTM A 536	BIBBY/STE. CROIX	VB825
			STAR	VB-5007
			DOMCAST	DF69 SERIES

40.22.04	Valve Box Base	OPSS 1850 Cast Iron to ASTM A48 or ASTM A 536	BIBBY/STE. CROIX	VB900
			STAR	VB-5007
			DOMCAST	DF69 SERIES
40.22.05	Extensions	300mm (12") Long OPSS 1850 Cast Iron to ASTM A48 or ASTM A 536	BIBBY/STE. CROIX	VB750
			STAR	VB-5023, VB-5024, VB-5025
			DOMCAST	DF69 SERIES
40.22.06	Large Boot Service Box Adapter	OPSS 1850 Cast Iron to ASTM A48 or ASTM A 536	DOMCAST	DCM900LB
40.22.07	Valve Box Riser	Risers shall be 1.5", 2" or 3" riser without flange, Telescopic riser or threaded riser threaded or inserted as applicable into the upper valve box section	BIBBY/STE. CROIX	VB740 SERIES (RISER) V852 (THREADED)
			STAR	VBR SERIES (RISER) VBAR SERIES (THREADED, TELESCOPIC)
40.23	FASTENERS			
40.23.01	BOLTS			
40.23.01.01	3/4" UNC x 4"	AWWA C-110 High strength, Corten (low alloy steel), Min yield strength of 45000 psi	BIBBY	FMC2337, FMC2112
40.23.01.02	3/4" UNC X 4 1/2"		INGERSOL FASTNER	
			STELCO	
			SIGMA	
			STAR	Bolt CS40, CS45
40.23.01.03	3/4" UNC x 4" Anti Rotational "T" Bolt & Nut	AWWA C-110 High strength, Corten (low alloy steel), Min yield strength of 45000 psi	STAR	Bolt AR40
40.23.01.04	3/4" UNC Corten Nuts			
40.23.02	Threaded Rod			
40.23.02.01	3/4" UNC threaded rod, nuts and washers	18-8 (304) stainless steel to ASTM F593 (rod) and F594 (hardware). Maximum installed rod length 1m long.		
40.24	WATER SERVICE MATERIALS			
40.24.01	CURB STOPS	AWWA C-800 Ball Type and Non Draining Inlet/Outlet Compression Joints for CTS	CAMBRIDGE BRASS	202NL-H4H4 25mm (1")
				202NL-C4C4 Copper flare 25mm (1")
				202NL-H6H6 37mm (1 1/2")
				202NL-C6C6 37mm (1 1/2")
				202NL-H7H7 50mm (2")
				202NL-C7C7 50mm (2")
			AY McDONALD	76100Q 25mm (1") - 50mm (2")
			MUELLER	B25209N
			FORD	B-44-444-Q-NL 25mm (1")
				B-44-666-Q-NL 37mm (1 1/2")
	B-44-777-Q-NL 50mm (2")			

40.24.02	MAIN STOP	AWWA C-800 Ball type, Inlet male AWWA Taper Thread / Outlet Compression joint for CTS	CAMBRIDGE BRASS	301NL-A4C4 25mm (1")
				301NL-A6H6 37mm (1 1/2")
				301NL-A6C6 37mm (1 1/2")
				301NL-A7H7 50mm (2")
			AY McDONALD	74701BQ 25mm (1") - 50mm (2")
			MUELLER	B25008N
			FORD	FB1000-4-NL 25mm (1")
				FB1000-6-Q-NL 37mm (1 1/2")
				FB1000-7-Q-NL 50mm (2")
			40.24.03	Compression Coupling
118NL-H3H3 19mm (3/4")				
118NL-H4H3 19mmx25mm transition				
120NL-V3V3 19mm (3/4")				
120NL-V4V4 25mm (1")				
120NL-V6V6 38mm (1 1/2")				
120NL-V7V7 50mm (2")				
AY McDONALD	74758Q 25mm (1") - 50mm (2")			
MUELLER	H15403N			
FORD	C44-44NL 25mm (1")			
	C44-33-NL 19mm (3/4")			
	C44-34-NL 19mmx25mm transition			
40.24.04	TRANSITION COUPLINGS 5/8" XS x 3/4" CTS Lead x Copper / Plastic Coupling	Inlet Compression for CTS/ Outlet compression joints for various pipe sizes	FORD	Q24-23
			CAMBRIDGE BRASS	CB119NL U2,U3,U4,U5
	5/8" XXS x 3/4" CTS Lead x Copper / Plastic Coupling	Inlet Compression for CTS/ Outlet compression joints for various pipe sizes	FORD	Q34-23
			CAMBRIDGE BRASS	CB119NL U2,U3,U4,U5
	3/4" XS x 3/4" CTS Lead x Copper / Plastic Coupling	Inlet Compression for CTS/ Outlet compression joints for various pipe sizes	FORD	Q24-33
			CAMBRIDGE BRASS	CB119NL U2,U3,U4,U5
	3/4" XXS x 3/4" CTS Lead x Copper / Plastic Coupling	Inlet Compression for CTS/ Outlet compression joints for various pipe sizes	FORD	Q34-33
			CAMBRIDGE BRASS	CB119NL U2,U3,U4,U5
	1" XXS x 1" CTS Lead x Copper / Plastic Coupling	Inlet Compression for CTS/ Outlet compression joints for various pipe sizes	FORD	Q34-44
			CAMBRIDGE BRASS	CB119NL U2,U3,U4,U5

40.24.05	INSERTS 19mm(3/4") -CTS 25mm(1") CTS 37mm(1 1/2") CTS 50mm(2") CTS	Stainless Steel Inserts Fluted End For 110 Compression Connection	FORD	INSERT-51, 52, 54, 55
			CAMBRIDGE BRASS	86-3, 86-4, 86-6, 86-7
			MUELLER	INSERTS
40.25	METER PITS			
40.25.01	Concrete Meter Pits for 16mm, 19mm & 25mm service meters in driveways and roads	Concrete Pit 533mm (21") Dia.		
40.25.02	Concrete Meter Pits for 37mm to 50mm service meters in driveways and roads	Concrete Pit 900mm (36") Dia.		
40.25.03	Plastic Meter Pits for 16mm, 19mm & 25mm service meters in boulevards with built in meter setter	Plastic Pit 500mm - 600mm (20" - 24") Dia 1320mm (52") standard min. Cylinder Length comes with built in plastic meter setter for 16mm (5/8"), 19mm (3/4"), and 25mm (1") meters	FORD	PDBB-288-20-60-NL (16mm, 19mm) PDBB-488-20-60-NL (25mm)
			AY MCDONALD	780W260WWPP 33x20 (16mm, 19mm) 780W460WWPP 44x20 (25mm)
			MUELLER	203RS1860FFBNN (16mm, 19mm) 330RS2160FFBNN (25mm)
			HYDRANT TECH	HT Fabricated Single Meter Pit (16mm, 19mm, 25mm) HT Fabricated Dual Meter Pit (16mm)
40.25.04	Plastic Meter Pits for 37mm to 50mm service meters in boulevards with built in meter setter	Plastic Pit 900mm (36") Dia 1320mm (52") standard min. Cylinder Length comes with built in plastic meter setter for 37mm (1.5") and 50mm (2") meters	FORD	PMBB-688-36HB-60-NL (37mm) PMBB-788-36HB-60-NL (50mm)
			AY MCDONALD	780-660WWPP 660x36 (37mm) 780-760WWPP 770x36 (50mm)
			MUELLER	500VS3660FFBN (37mm) 550VS3660FFBN (50mm)
40.25.05	Meter Cover	Double lid Cover (Frame, Top lid and inner cover) or equivalent	FORD	W3H, W3 MC-36-MB
			AY MCDONALD	74M3WH, 74M3W 74M36IL
			DOMCAST	DFWV11
			MUELLER	780069 (Grass only) 693H10811 (Frost lid)

40.25.06	Meter Setter for concrete pits only	inlet lockable angle ball valve, outlet angle ball valve no by-passes allowed. Setter to be properly secured to the pit	FORD	VBB81W-44-44-Q-NL 16mm (5/8") VBB83W-44-44-Q-NL 19MM (3/4") VBB84W-44-44-Q-NL 25mm (1") VBB76-12B-44-66-NL 38mm (1.5") VBB77-12B-44-77-NL 50mm (2")
			CAMBRIDGE BRASS	6040NL-212H4H4-VV 16mm (5/8") 6040NL-312H4H4-VV 19mm (3/4") 6040NL-412H4H4-VV 25mm (1") 6020NL-612-F6F6-UU 38mm (1.5") 6020NL-712-F7F7-UU 50mm (2")
			AY MCDONALD	731-212WWQQ-44 16mm (5/8") 731-312WWQQ-44 19mm (3/4") 731-412WWQQ-44 25mm (1") 730-612WWFF-660 38mm (1.5") 730-712WWFF-770 50mm (2")
40.26	MISCELLANEOUS			
40.26.01	Pipe Joint Lubricant	NSF/ANSI 61-2008 AWWA C-111 SEC. 4.4.4 Lubricant to be food grade only		
40.26.02	Casing Spacers	Plastic, polyethylene WUC approval needed	ADVANCED PRODUCTS & SYSTEM	Model SS1 OR CI
40.26.03	Casing Rubber End Seals	Synthetic Rubber	LINK SEAL	Thunderline Link Seal
			ADVANCED PRODUCTS & SYSTEM	
			PSI	PSI End Seal
40.26.04	Automatic and Continuous Flusher		KUPFERLE	Eclipse #9800
40.26.05	Warning Tape	blue in colour, big bold black lettering with "caution- buried potable water line below" , 4 to 6 mm thick organic polyethylene coating.	PRO-LINE SAFETY	
40.26.06	Hardwood Wedges			
40.26.07	Solid Concrete Bricks/ Blocks			
40.26.08	Irrigation Box	To be used for backflow prevention for summer services	HIGHLINE PRODUCTS	LUB, XLUB
40.FM.01	FOR FIRE MAINS			
40.FM.01.01	MAIN STOP- 25mm	AWWA C-800 Ball type, rated 300 psi min. Inlet Male AWWA Thread / Outlet Compression Joint for CTS	CAMBRIDGE BRASS	301NL-A4H4 25mm (1")
			FORD	FB-1000-4-NL
			MUELLER	B25008N
40.FM.01.02	CURB STOP- 25mm	AWWA C-800 rated 300 psi min. Ball Type Non-Draining	CAMBRIDGE BRASS	202NL-H4H4 25mm
			FORD	B44-444-Q-NL
			MUELLER	B25209N
40.FM.01.03	COUPLING 19mm and 25mm	End Coupling rated 200 psi 19mm and 25mm Compression Joint		



WINDSOR UTILITIES COMMISSION WATER DIVISION CITY OF WINDSOR

DESIGN GUIDELINES AND SPECIFICATIONS FOR THE INSTALLATION OF WATER MAINS AND SERVICES

PART 50 STANDARD DRAWINGS

Revisions

- Dec 2024 - 50.01.01 - Added "winter" sand, added "1/4 minus screenings"
- Dec 2024 - 50.03.01 - Added tracing wire & note #2
- Dec 2024 - 50.07.01 - Added note #3
- Dec 2024 - 50.07.02 - Added note #2
- Dec 2024 - 50.07.03 - Added note #2
- Dec 2024 - 50.08.01A - See drawing for changes
- Dec 2024 - 50.08.01B - Removed concrete pit for dual 16mm meters
- Dec 2024 - 50.08.01B - Replaced with hand-made setter (concrete only)
- Dec 2024 - 50.08.02A - Added clear stone, note #3, 90° elbow, size range
- Dec 2024 - 50.08.02B - Added clear stone, note #3, size range
- Dec 2024 - 50.08.03 - Added clear stone, changed lid
- Dec 2024 - 50.08.04 - Added blocking, clear stone, note #3, Removed hand made setter portion, changed lid
- Dec 2024 - 50.09.04 - Removed water service valves before meters
- Dec 2024 - 50.09.06 - Added profile view, notes #3 & #4, Changed >6 to 4 meters minimum
- Dec 2024 - 50.15.01, 50.15.02 - Added to Drawings



INDEX

STANDARD DRAWINGS

FOR THE INSTALLATION OF WATERMAINS AND SERVICES

DRAWING NO.

50.01.01	Trench Width, Bedding, and Cover for PVC Watermain up to 300mm Diameter
50.01.02	Insulation of Watermains and Water Services at Obstruction
50.01.03	Watermain Crossing at Sewers
50.02.01	Typical 50mm Diameter Permanent Blow-Off Assembly
50.02.02	Temporary Full Size Blow-Off
50.02.03	Typical Chlorine Riser and Sampling Point Installation
50.02.04A	Watermain Flushing and Testing Procedure in Roadway
50.02.04B	Watermain Flushing and Testing Procedure in Boulevard
50.02.04C	Watermain Flushing and Testing Procedure in Roadway
50.02.05	Standard Tie-in Details
50.03.01	Valve Setting on a PVC Watermain
50.04.01	Fire Hydrant Installation with Tee and Valve
50.04.02	Fire Hydrant Installation with Tapping Valve
50.04.03	Hydrant Colour Codes
50.05.01	Typical Watermain Under Building Footing - Domestic
50.05.02	Typical Watermain Through Building Footing - Domestic
50.05.03	Typical Watermain Through Building Wall - Domestic
50.05.04	Typical Watermain Under Building Footing - Fire



- 50.05.05 Typical Watermain Through Building Wall - Fire
- 50.05.06 Typical Watermain Through Building Footing - Fire
- 50.06.01 PVC Pipe Joint Thrust Restraint
- 50.06.02 Tie in and Thrust Blocking
- 50.07.01 Typical Residential Water Service and Meter Installation
- 50.07.02 Copper/PEX Service Connections – Main to Property Line
- 50.07.03 Water Service Connection to Existing Metal Service in Private Property
- 50.07.04 Water Service Transfer Installation
- 50.07.05 Water Service Transfer Installation – Full Street Width
- 50.07.06 Water Service Transfer Installation – Full Street Width
- 50.07.07 Typical Sampling Station Installation
- 50.08.01A Concrete Meter Pit for 20mm and 25mm Diameter Services in Driveways and Roads
- 50.08.01B Hand-made meter setter for 16mm, 19mm & 25mm meters (Conc only)
- 50.08.02A Plastic Meter Pit for 16mm, 19mm and 25mm Diameter Services in Blvd
- 50.08.02B Plastic Meter Pit and setters for dual 16mm meters only in grass areas
- 50.08.03 Concrete Meter Pit and Setters for Flanged Meter Settings 38mm and 50mm
- 50.08.04 Plastic Meter Pit and Setters for Flanged Meter Settings 38mm and 50mm in Blvd
- 50.08.05 75mm and Above Meter Installation in Manhole
- 50.08.06 Metered Automatic Flushing Device
- 50.08.07 Meter & Backflow Preventer for Summer Service
- 50.09.01A Water Servicing for Multiple Buildings on One Lot for Industrial, Commercial, Institutional and Apartment Buildings – Option ‘A’



- 50.09.01B Water Servicing for Multiple Buildings on One Lot for Industrial – Option ‘B’
- 50.09.01C Water Servicing for Multiple Buildings on One Lot for Commercial, Institutional and Apartment Buildings – Option ‘C’
- 50.09.01D Water Servicing for Multiple Buildings on One Lot for Industrial – Option ‘D’
- 50.09.01E Water Servicing for Multiple Buildings on One Lot for Commercial, Institutional and Apartment Buildings – Option ‘E’
- 50.09.02A Domestic Water Service for Industrial, Commercial, Institutional – Option ‘A’
- 50.09.02B Domestic Water Service for Commercial, Institutional, and Apartment Buildings – Option ‘B’
- 50.09.03A Fire and Domestic Water Servicing for Commercial, Institutional, and Apartment Buildings – Option ‘A’
- 50.09.03B Fire and Domestic Water Servicing for Industrial Properties – Option ‘B’
- 50.09.03C Fire and Domestic Water Servicing for Commercial, Institutional, and Apartment Buildings – Option ‘C’
- 50.09.03D Fire Hydrant Lead and Domestic Water Servicing for Industrial – Option ‘D’
- 50.09.04 Multi Water Meter Arrangement with Individual Shutoffs
2, 3 or 4-Plex Residential Only
- 50.09.05 Single Water Meter Arrangement for Single or Multi Single Residential Buildings
- 50.09.06 Multi Water Meter Arrangement with Meters in a Meter Room
- 50.09.07 Proposed Premise Isolation Device Installation
- 50.10.01A Abandonment Options for Residential Properties
- 50.10.01B Abandonment Options for Industrial, Commercial, and Institutional Properties
- 50.11.01 Pipe Casing Installation
- 50.12.01 Tracer Wire Installation
- 50.13.01 Magnesium and Zinc Anode Installation
- 50.13.02 Anode Installation in Augured Hole



- 50.13.03 Test Station Installation
- 50.13.04 Typical Galvanic Anodes (Bank of Five)
- 50.14.01A Feedermain Support – Cross Section Example
- 50.14.01B Feedermain Support – Typical Reinstatement/Bedding Detail Cross Section
- 50.14.01C Feedermain Support – General Submission and Design Requirements
- 50.15.01 Bypass Removal
- 50.15.02 Single Meter Installation or Downsizing (1.5" to 2")

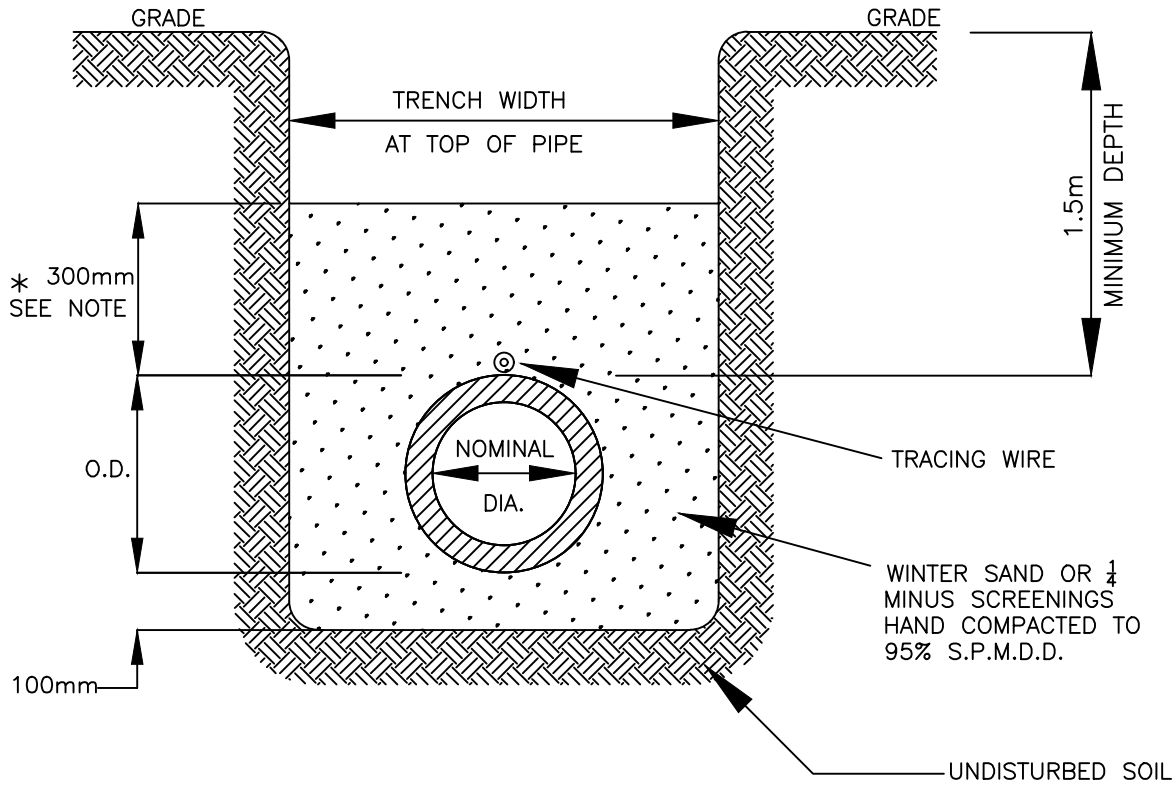

NOMINAL DIA. (mm)	TRENCH WIDTH (mm)	
	MIN.	MAX.
25	650	775
50	650	775
100	650	775
150	650	775
200	700	825
250	750	875
300	800	950

NOTE:

1. ALL WATERMAINS TO BE INSTALLED AT 1.68M± (0.3M) DEPTH UNLESS OTHERWISE DIRECTED BY THE ENGINEER.
2. * USE 600mm COVER IN AREAS WHERE BACKFILL AGGREGATE SIZE EXCEEDS 19mm DIA.
3. WHERE TWO WATER SERVICE PIPES ARE INSTALLED IN SAME TRENCH THE CLEAR DISTANCE BETWEEN PIPES SHALL BE 1000mm MIN.
4. TRENCH WIDTH, BEDDING AND COVER FOR PIPING GREATER THAN 300mm IN DIA. SHALL BE APPROVED BY WUC.



TRENCH WIDTH, BEDDING AND COVER FOR PVC WATERMAIN PIPING UP TO 300mm DIAMETER

DRAWN BY:	CHECKED BY:	APPROVED BY:	REVISION DATE:	DWG. NO.:
	V.S.	N.P.	NOV. 2024	50.01.01

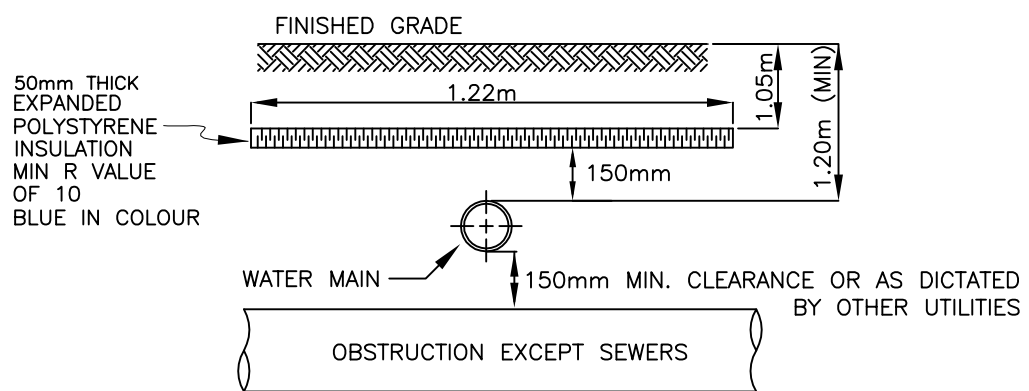
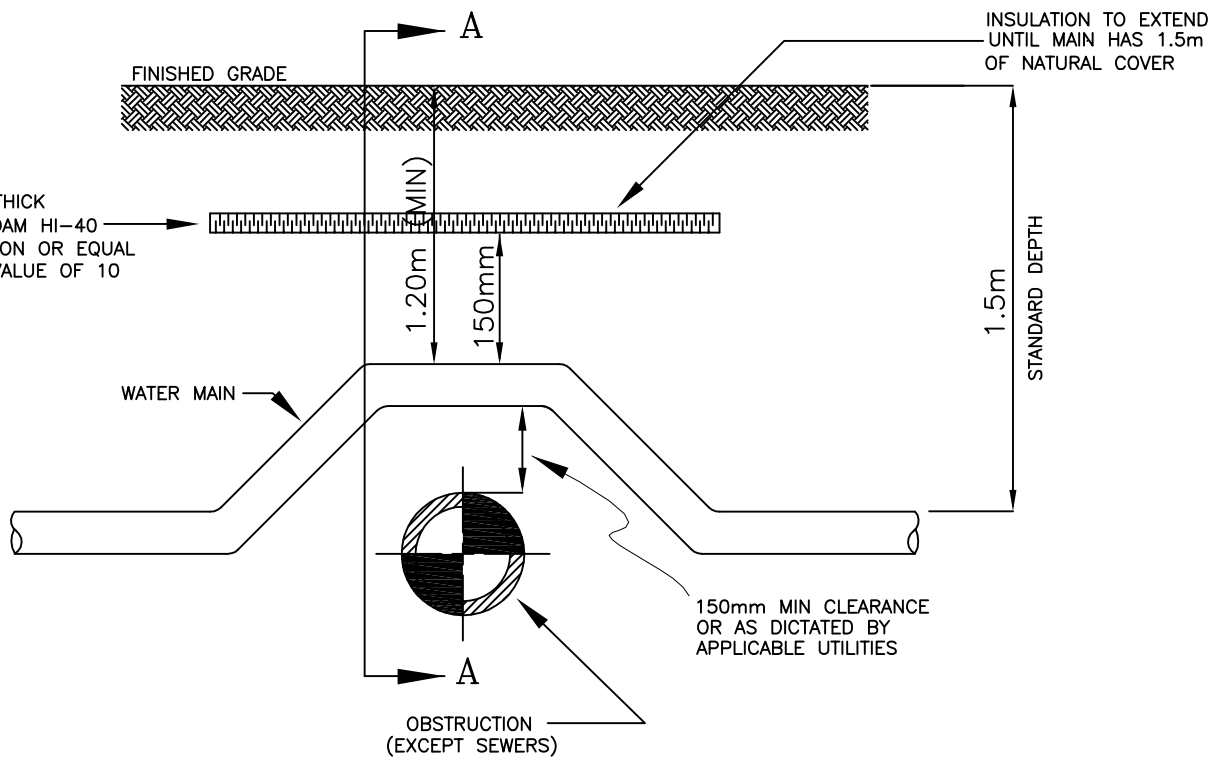

SECTION A-A

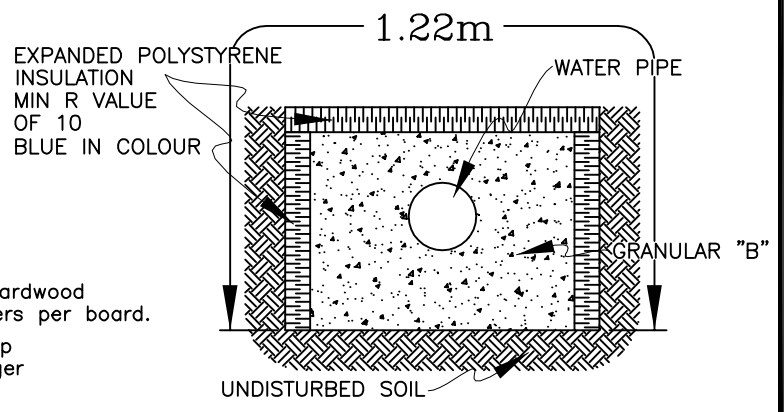

Insulation shall be installed in thickness required, in strict accordance with the insulation manufacturer's directions. Insulation shall be installed over 150mm of fine granular fill screeded smooth.

Butt insulation tightly together without gaps. Stagger end joints if more than one layer is used. To hold in place skewer insulation board to ground with 200mm hardwood skewers; min. 6mm dia. and 200mm long with 2 skewers per board.

If two layers of insulation are used, skewer only the top layer through the first layer with a skewer 150mm longer than the combined length of the 2 layers of insulation.

Insert skewers at appx. a 30° angle.

Place at least 200mm of fine granular fill over insulation before using compaction equipment.



INSULATION OF WATERMANS AND WATER SERVICES AT OBSTRUCTION

DRAWN BY:	CHECKED BY: V.S.	APPROVED BY: N.P.	REVISION DATE: JUNE 04/2010	DWG. NO.: 50.01.02
-----------	---------------------	----------------------	--------------------------------	-----------------------

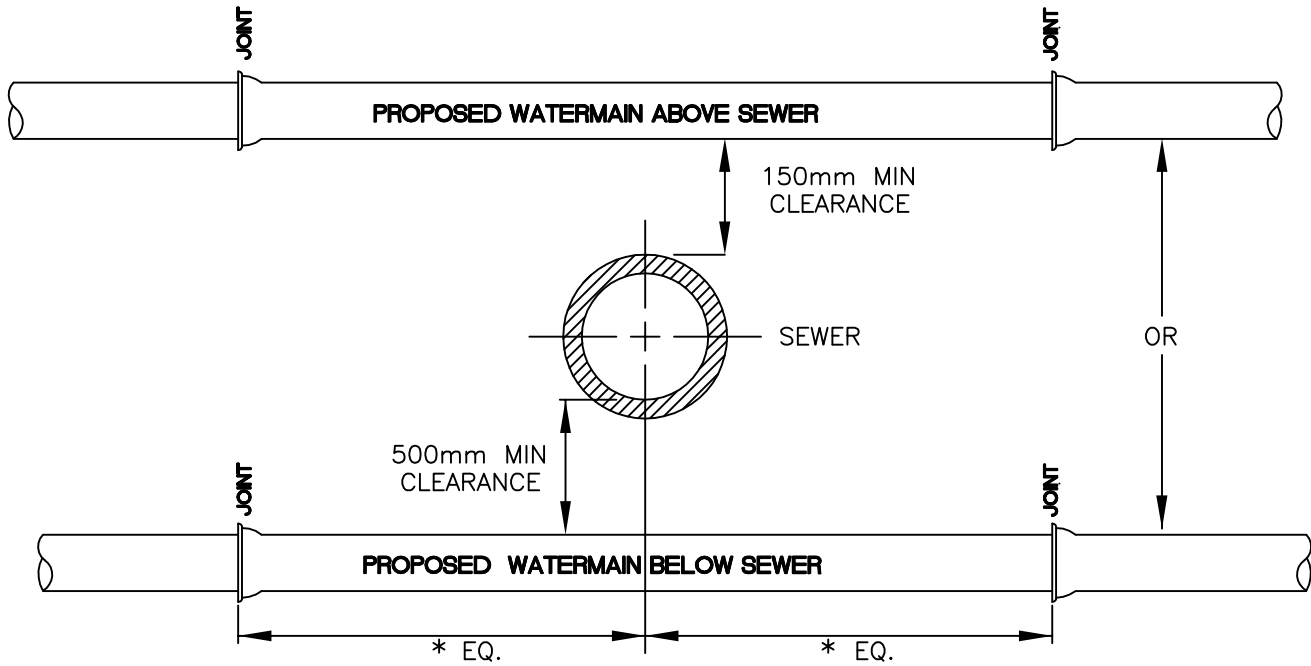

*ALL JOINTS TO BE EQUIDISTANT AND AS FAR AS POSSIBLE FROM SEWER

NOTE:
BENDS OR DEFLECTION TO BE INCORPORATED INTO WATERMAIN INSTALLATION TO MAINTAIN NECESSARY CLEARANCES

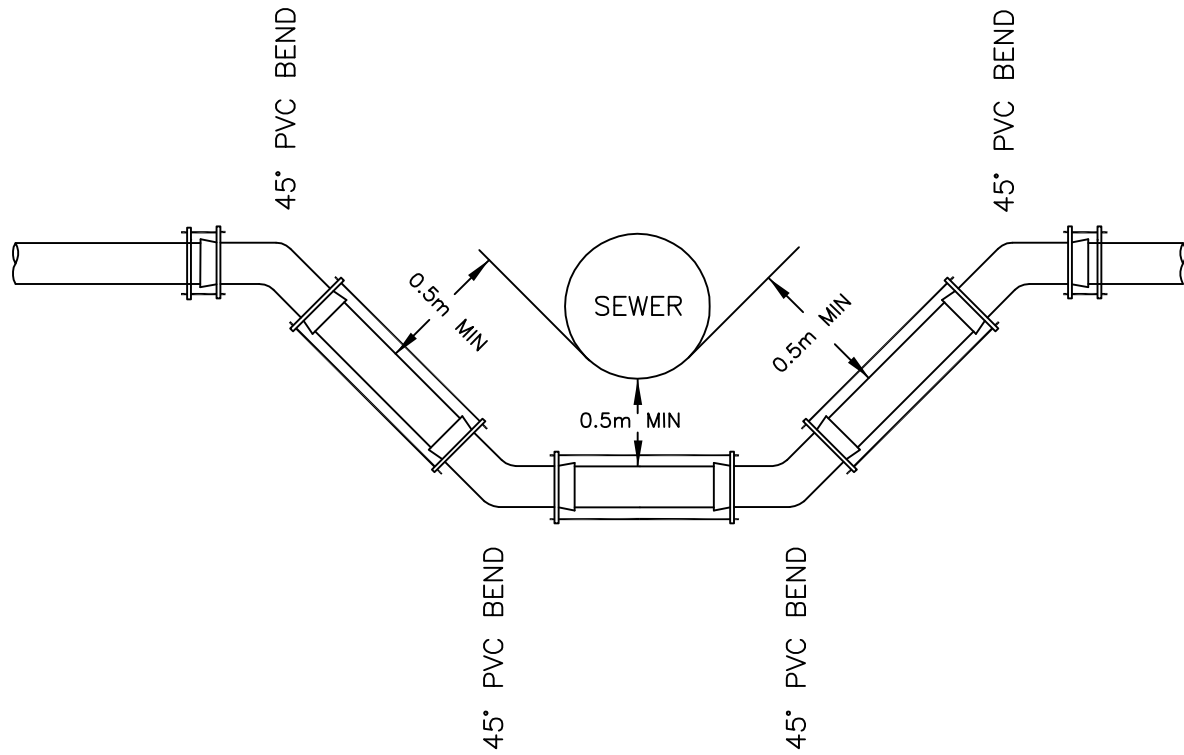

WATERMAIN CROSSINGS AT SEWERS

DRAWN BY:	CHECKED BY: V.S.	APPROVED BY: N.P.	REVISION DATE: SEPT - 2012	DWG. NO.: 50.01.03
-----------	---------------------	----------------------	-------------------------------	-----------------------

NOTE:
 ALL 50mm ϕ BLOW-OFF ASSEMBLIES SHALL
 BE CONSTRUCTED FROM NEW PIPE MATERIALS.

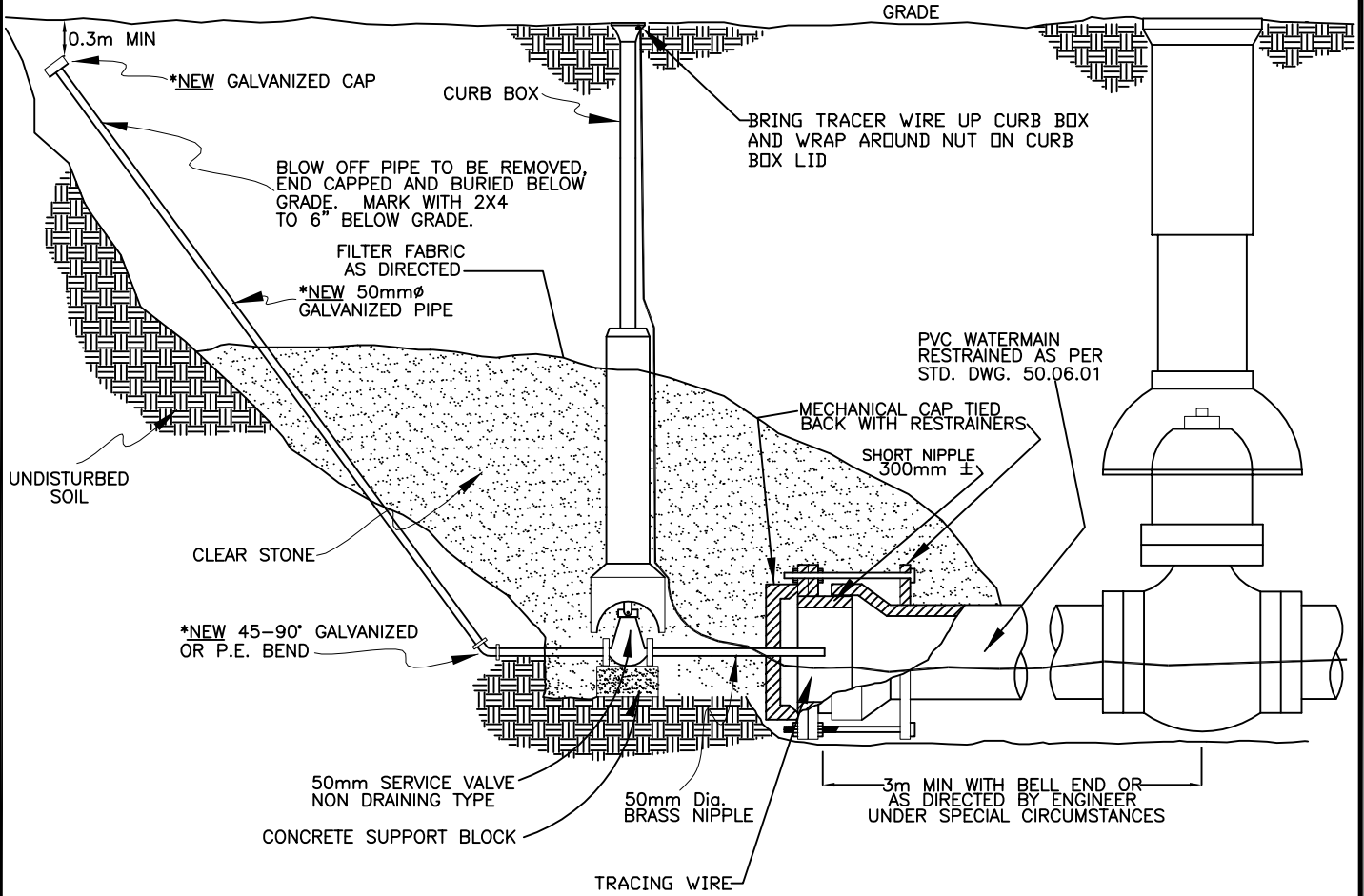
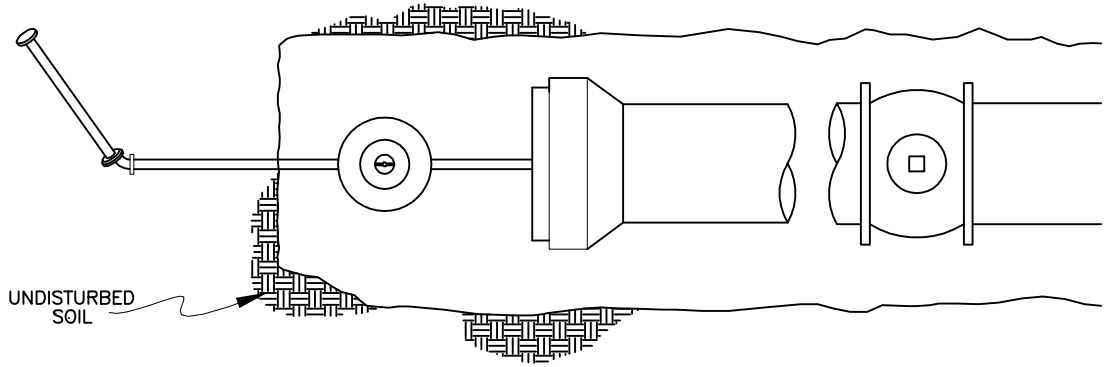

TYPICAL 50mm DIAMETER PERMANENT BLOW-OFF ASSEMBLY

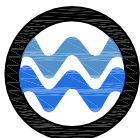

WINDSOR
 UTILITIES
 COMMISSION

DRAWN BY:	CHECKED BY:	APPROVED BY:	REVISION DATE:	DWG. NO.:
	V.S.	N.P.	OCT. / 2016	50.02.01

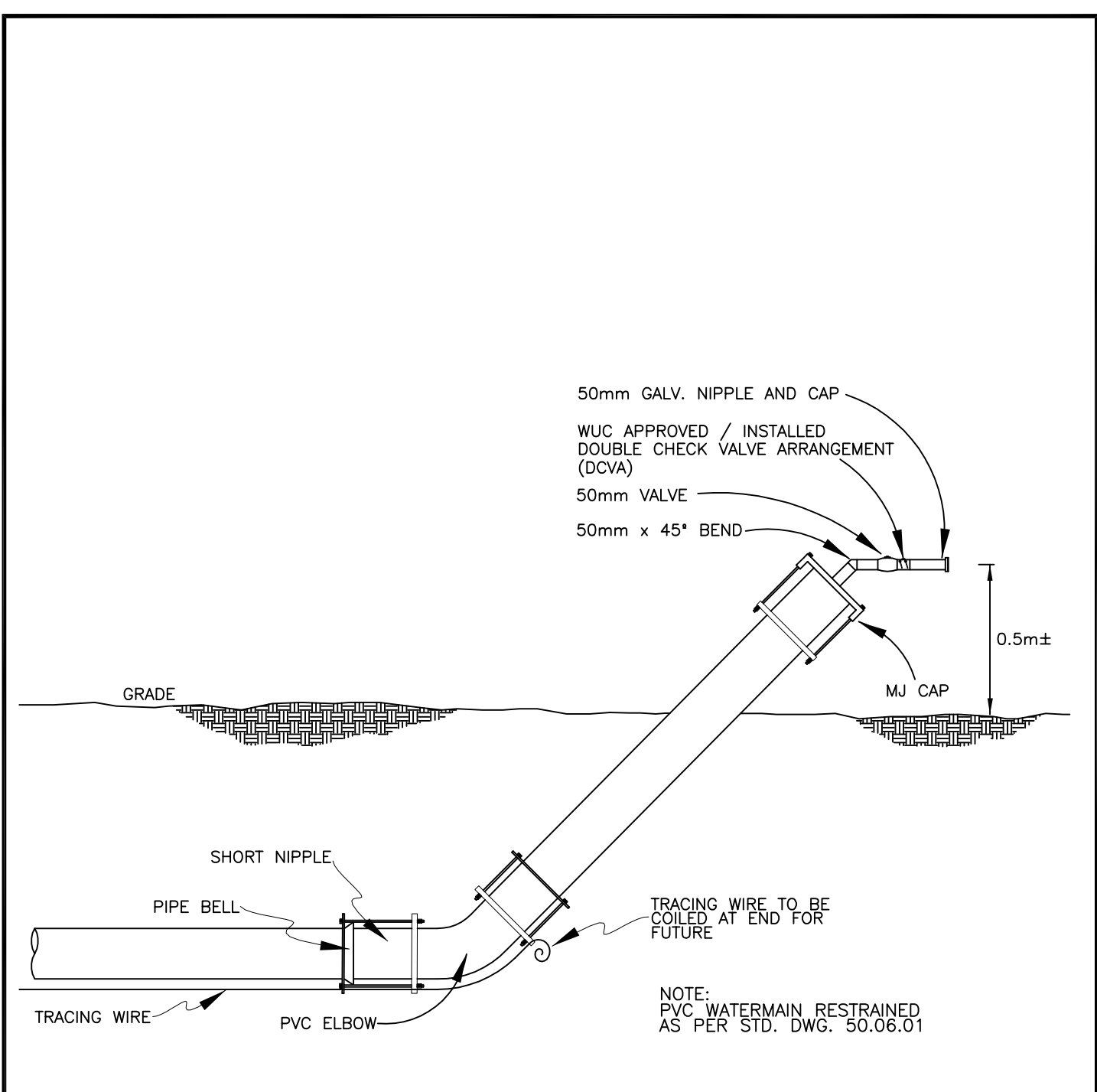

NOTE:
 ALL 50mm ϕ BLOW-OFF ASSEMBLIES SHALL
 BE CONSTRUCTED FROM NEW PIPE MATERIALS.

NOTE:
 PVC WATERMAIN RESTRAINED
 AS PER STD. DWG. 50.06.01



TEMPORARY FULL SIZE BLOW OFF

DRAWN BY:	CHECKED BY: V.S.	APPROVED BY: N.P.	REVISION DATE: JUNE 04/2010	DWG. NO.: 50.02.02
-----------	---------------------	----------------------	--------------------------------	-----------------------

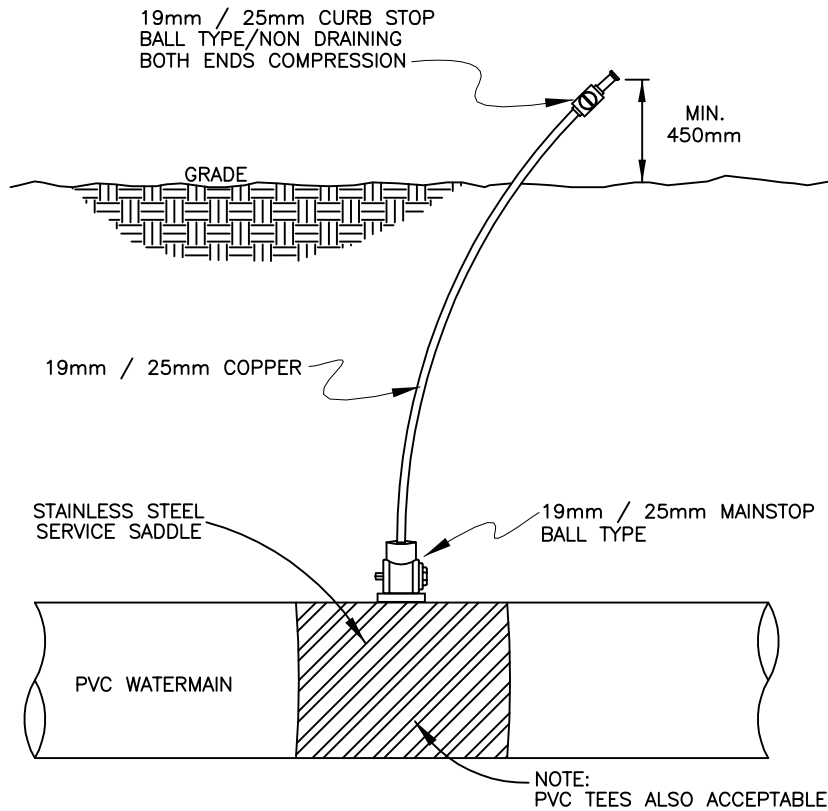

NOTE:

19mm / 25mm MAIN STOP AND SERVICE SADDLES TO BE NEW MATERIAL

THE 19mm / 25mm RISER PIPE, VALVE AND PLUG MUST BE CLEAN AND IN GOOD OPERATING CONDITION

CLOSE MAINSTOP. CHLORINE RISER TO BE REMOVED AFTER TESTING AND DISINFECTION OF WATERMAIN IS COMPLETED

NEW WATERMAIN WILL NOT BE PLACED IN SERVICE UNTIL REMOVAL HAS BEEN COMPLETED

W.U.C. WATER ENGINEERING STAFF MUST BE PRESENT ON SITE TO WITNESS THE REMOVAL OPERATION

IN WINTER CONDITIONS THE EXPOSED PIPE TO BE ADEQUATELY INSULATED TO PREVENT FREEZING

NOTE:

ALL CHLORINE RISER AND SAMPLING POINT ASSEMBLIES SHALL BE CONSTRUCTED FROM NEW MATERIALS.

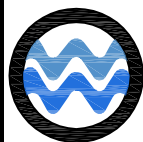

WINDSOR
UTILITIES
COMMISSION

TYPICAL CHLORINE RISER AND SAMPLING POINT INSTALLATION

DRAWN BY:

CHECKED BY:

V.S.

APPROVED BY:

N.P.

REVISION DATE:

JUNE 04/2010

DWG. NO.:

50.02.03

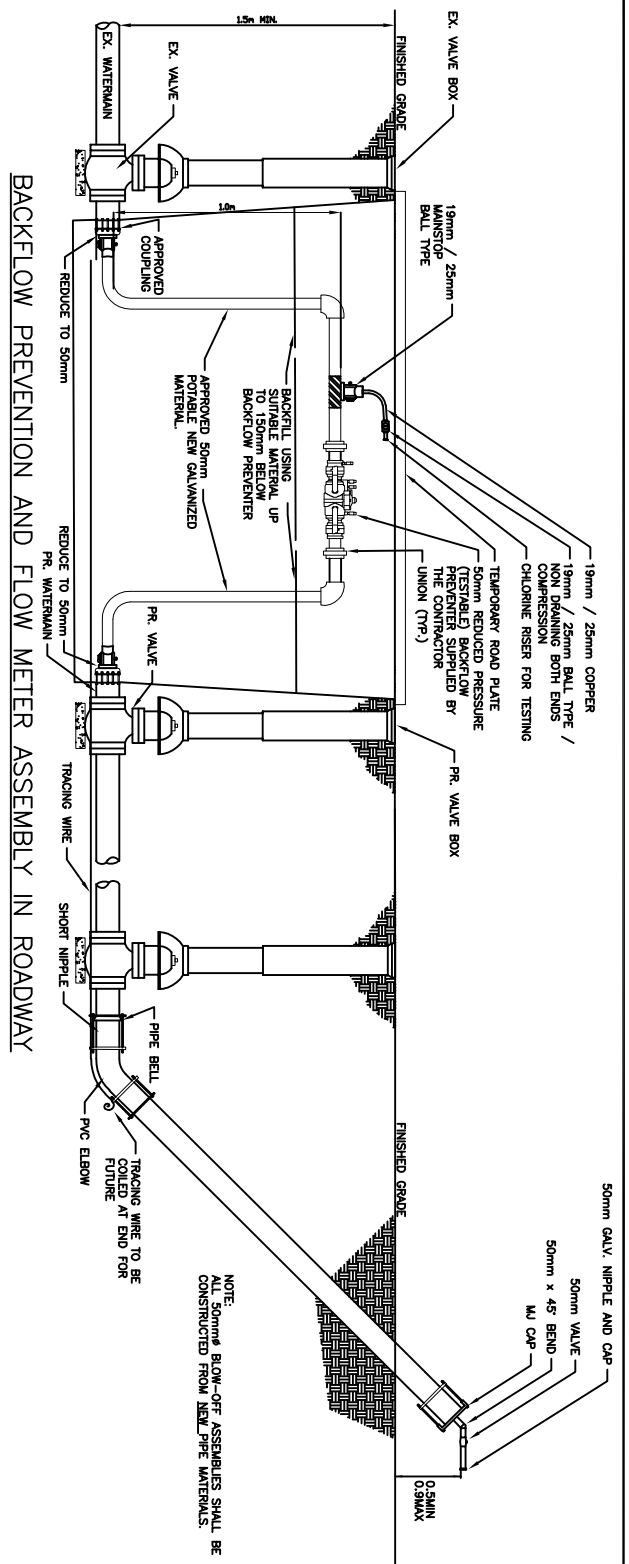

BACKFLOW PREVENTION AND FLOW METER ASSEMBLY IN ROADWAY

NOTE:
ALL 50mm BLOW-OFF ASSEMBLIES SHALL BE CONSTRUCTED FROM NEW PIPE MATERIALS.

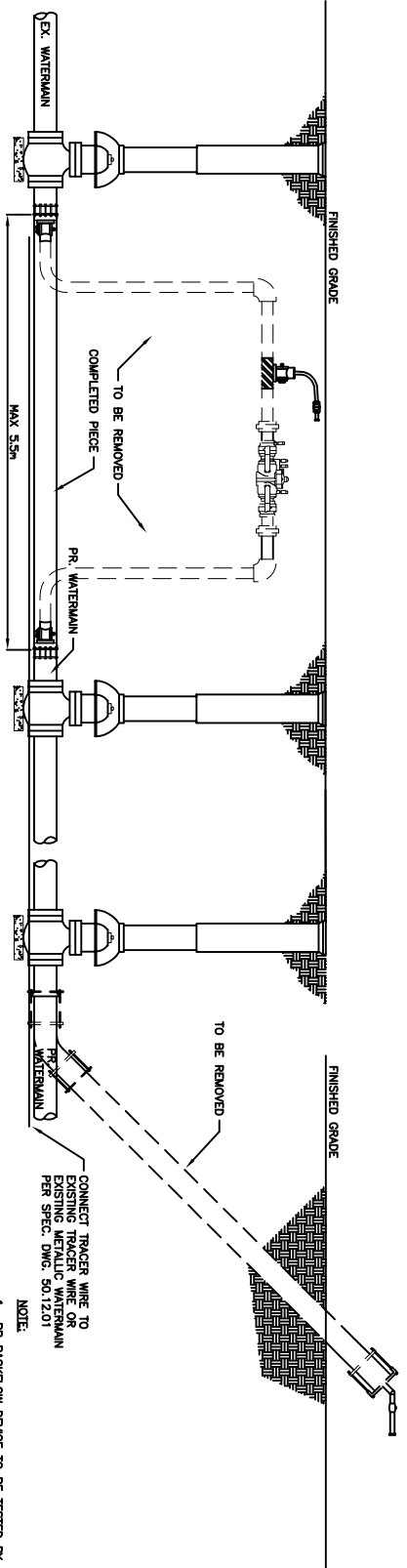

WATERMAIN COMPLETION ASSEMBLY

INTERCONNECTION	
WM SIZE	MINIMUM CONNECTION SIZE
≤ 300mm	50mm
> 300mm	100mm

- NOTE:
1. RP BACKFLOW DEVICE TO BE TESTED BY AN APPROVED TESTER AFTER INSTALLATION FOR EACH JOB WITH TEST REPORT FORWARDED TO EWIN PRIOR TO TESTING OF THE WATERMANS.
 2. THE REMOVAL OF BACKFLOW PREVENTION ASSEMBLY IS DONE ONLY AFTER ALL TESTS HAVE PASSED.
 3. ENSURE COMPLETION PIECE IS LESS THAN 5.5m AND DISINFECTED ACCORDING TO AWMA 651-05.
 4. A PHYSICAL SEPARATION MUST BE MAINTAINED AT ALL EXISTING SYSTEMS UNTIL BACTERIOLOGICAL TESTS HAVE PASSED. A SAMPLING POINT MUST BE PROVIDED AT THE END OF EACH BRANCH OR STUB.
 5. FREEZING PROTECTION MUST BE PROVIDED WHEN ALL JOINTS TO BE RESTRAINED PER WUC STD. DWG. 50.06.01.
 6. BACKFLOW ASSEMBLY TO BE LOCATED IN THE BOULEVARD IF POSSIBLE. ROAD PLATE REQUIRED IF INSTALLED IN ROADWAY.
 7. ALL PIPEWORK SHALL BE INSTALLED IN ACCORDANCE WITH THE WUC STANDARD SPECIFICATIONS.
 8. UNLESS UNDER DIRECT SUPERVISION OF A CERTIFIED OPERATOR.

WATERMAIN FLUSHING AND TESTING PROCEDURE DRAWING IN ROADWAY

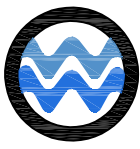

WINDSOR UTILITIES COMMISSION

DRAWN BY:	CHECKED BY: B.J.O.	APPROVED BY: N.P.	REVISION DATE: NOVEMBER 2022	DWG. NO.: 50.02.04A
-----------	-----------------------	----------------------	---------------------------------	------------------------

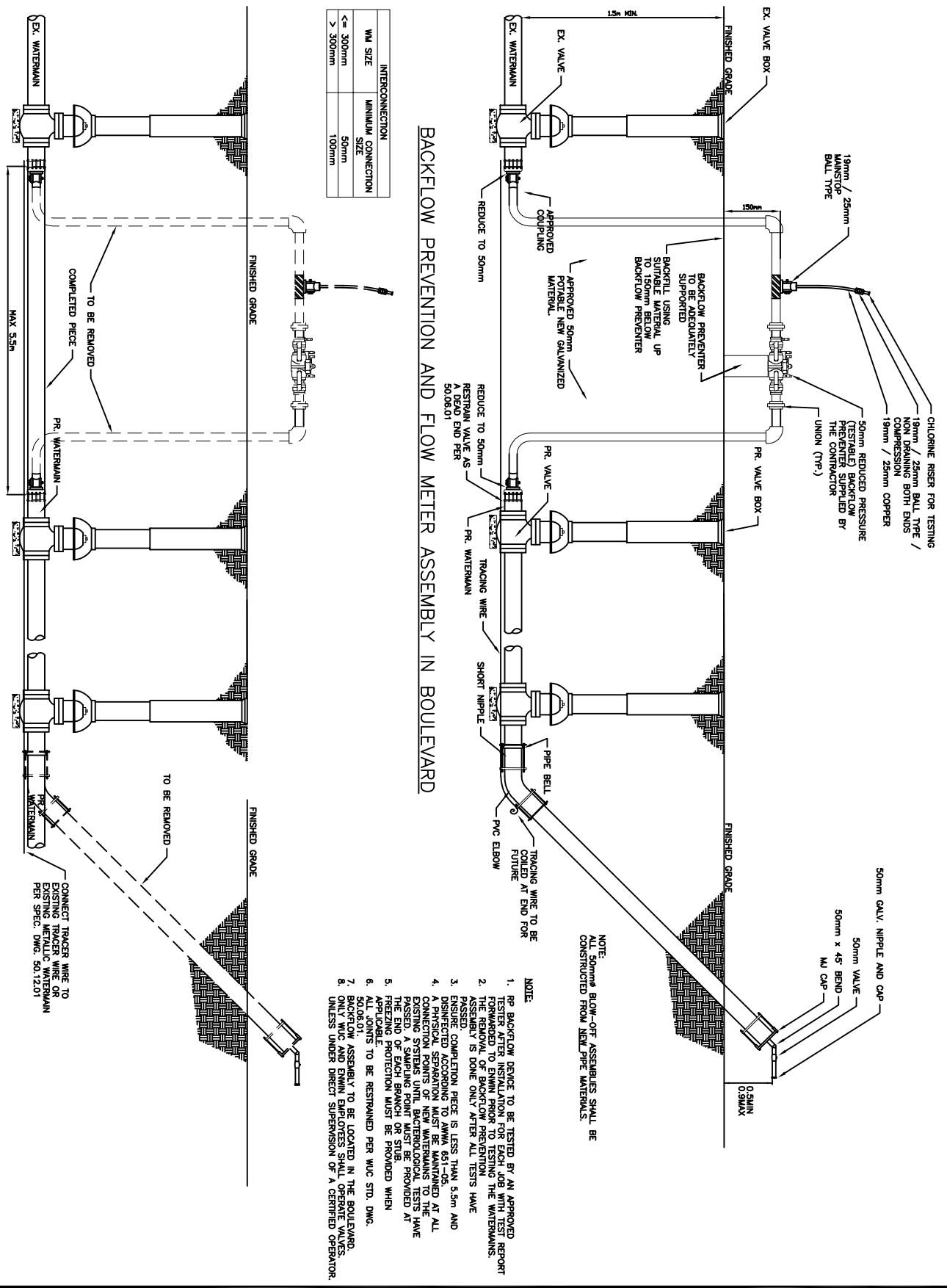

WATERMAIN FLUSHING AND TESTING PROCEDURE DRAWING IN BOULEVARD

DRAWN BY:	CHECKED BY:	APPROVED BY:	REVISION DATE:	DWG. NO.:
	B.J.O.	N.P.	NOVEMBER 2022	50.02.04B

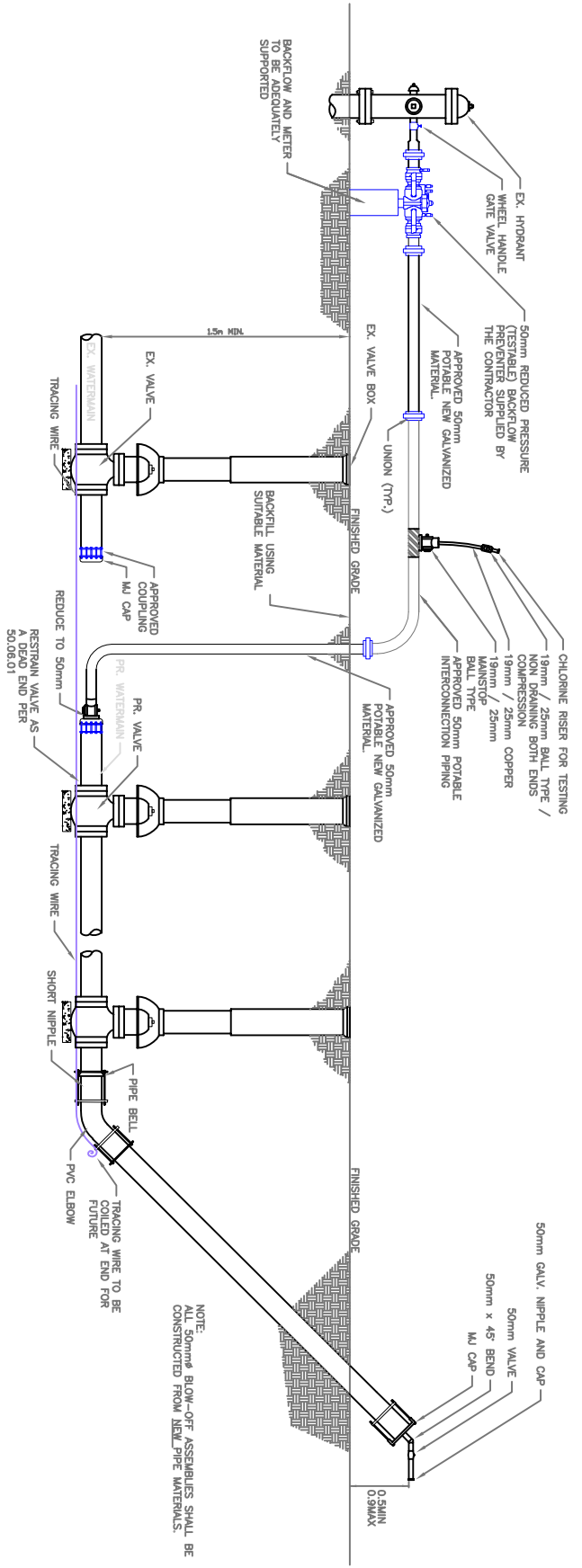

BACKFLOW PREVENTION AND FLOW METER ASSEMBLY IN ROADWAY

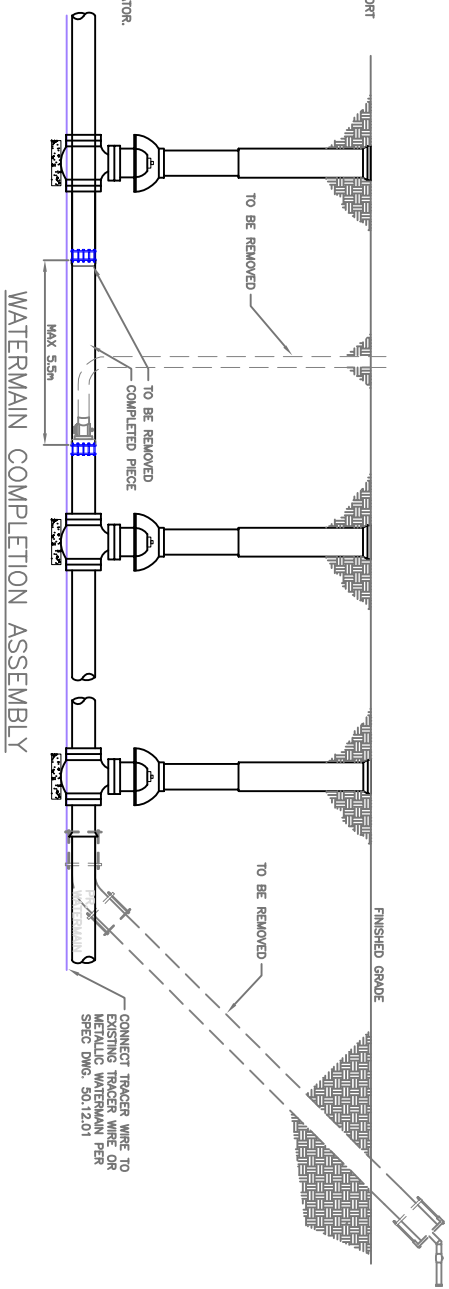

WATERMAIN COMPLETION ASSEMBLY

- NOTE:**
1. RP BACKFLOW DEVICE TO BE TESTED BY AN APPROVED TESTER AFTER INSTALLATION FOR EACH JOB WITH TEST REPORT FORWARDED TO ENWIN PRIOR TO TESTING THE WATERMANS.
 2. THE REMOVAL OF BACKFLOW PREVENTION ASSEMBLY IS DONE ONLY AFTER ALL TESTS HAVE PASSED.
 3. ENSURE COMPLETION PIECE IS LESS THAN 5.5m AND DISINFECTED ACCORDING TO AWWA 651-05.
 4. A PHYSICAL SEPARATION MUST BE MAINTAINED AT ALL EXISTING SYSTEMS UNTIL BACTERIOLOGICAL TESTS HAVE PASSED. A SAMPLING POINT MUST BE PROVIDED AT THE END OF EACH BRANCH OR STUB.
 5. FREEZING PROTECTION MUST BE PROVIDED WHEN PERFORMING THIS WORK.
 6. ALL JOINTS TO BE RESTRAINED PER WIC STD. DWG. 50.06.01.
 7. BACKFLOW ASSEMBLY TO BE LOCATED IN THE BOULEVARD.
 8. ONE BOULEVARD SWIMN EMPLOYEES SHALL OPERATE VALVES UNLESS UNDER DIRECT SUPERVISION OF A CERTIFIED OPERATOR.

INTERCONNECTION	
WM SIZE	MINIMUM CONNECTION SIZE
<= 300mm	50mm
> 300mm	100mm



WATERMAIN FLUSHING AND TESTING PROCEDURE DRAWING IN ROADWAY

DRAWN BY:	CHECKED BY:	APPROVED BY:	REVISION DATE:	DWG. NO.:
	B.J.O.	N.P.	NOVEMBER 2022	50.02.04C

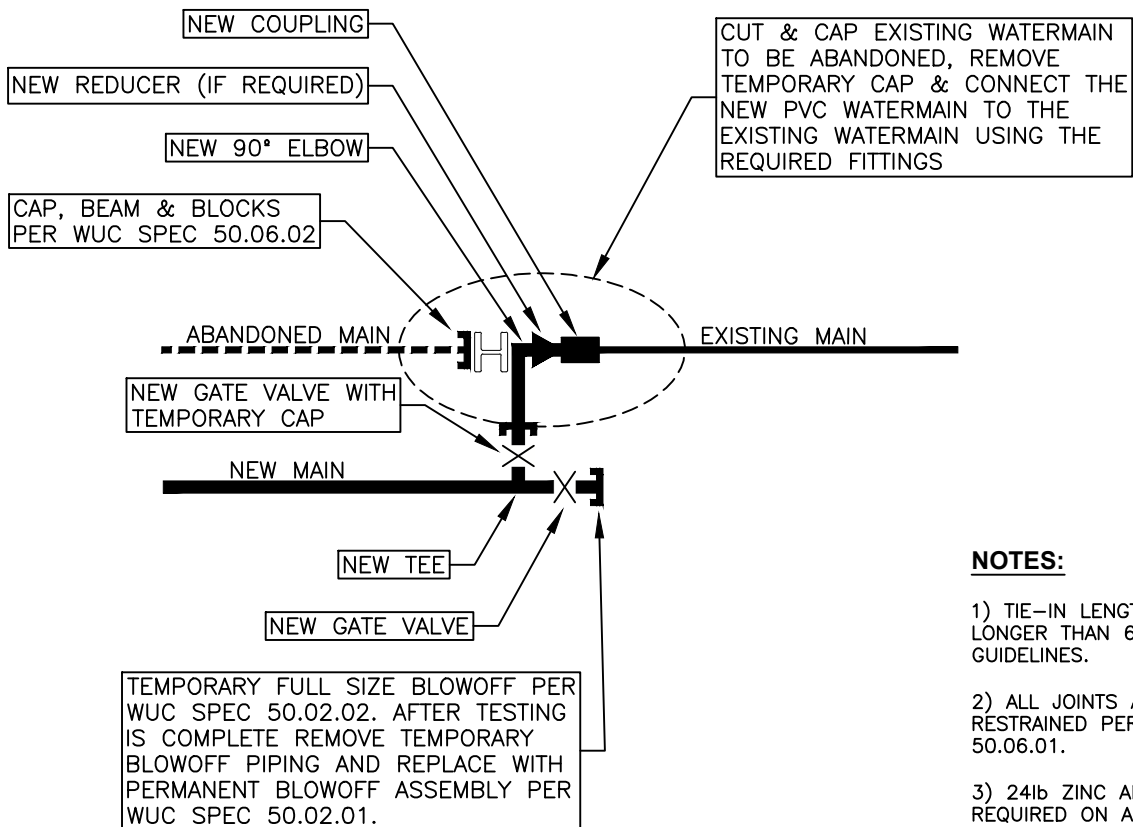
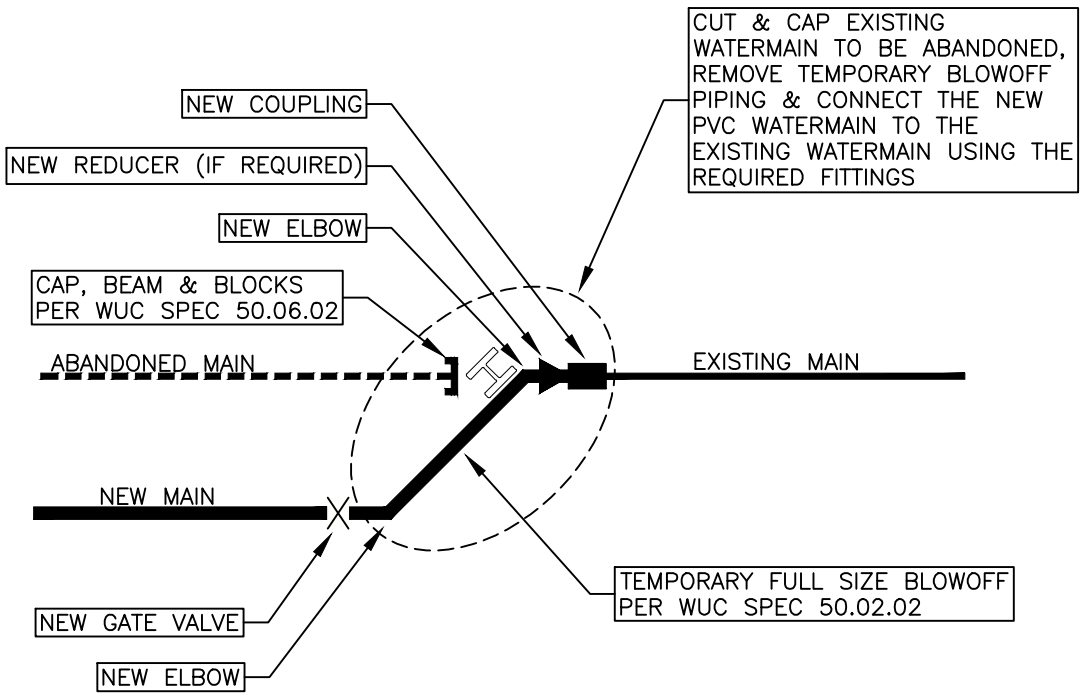

NOTES:

- 1) TIE-IN LENGTH MUST NOT BE LONGER THAN 6.0m PER MECP GUIDELINES.
- 2) ALL JOINTS ARE TO BE RESTRAINED PER WUC SPEC 50.06.01.
- 3) 24lb ZINC ANODES ARE REQUIRED ON ANY METALLIC FITTINGS AND CONNECTIONS TO EXISTING METALLIC WATERMAINS.

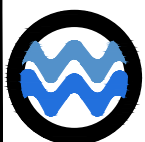

WINDSOR
UTILITIES
COMMISSION

STANDARD TIE IN DETAILS

DRAWN BY:
M.L.

CHECKED BY:
S.J.

APPROVED BY:
C.M.

REVISION DATE:

DWG. NO.:
50.02.05

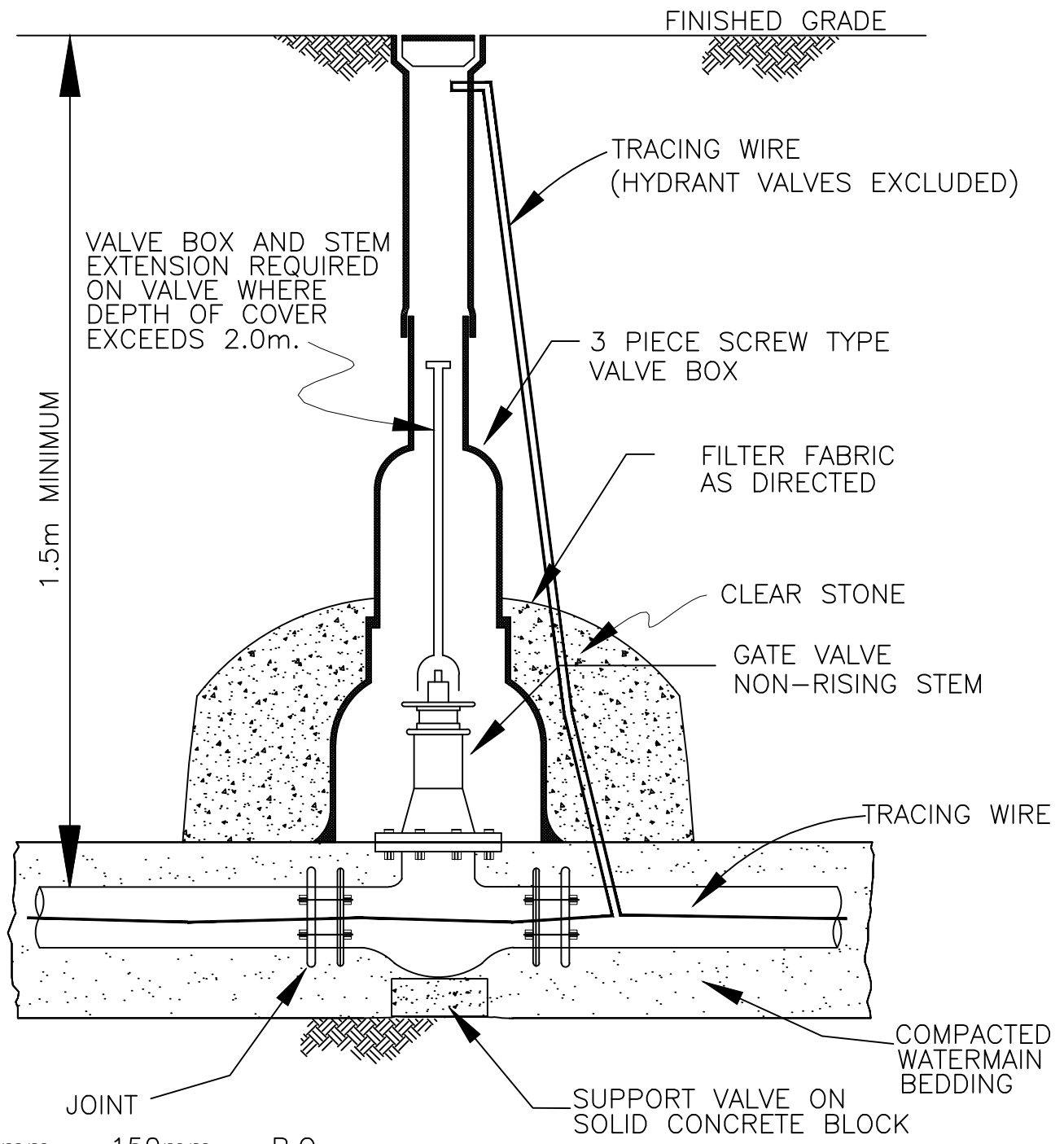

100mm – 150mm – P.O.
 >150mm – M.J.

NOTE:
 1. COMPACT ALL BACKFILL AROUND ALL VALVE BOXES TO ASSURE THAT THEY REMAIN VERTICAL AFTER TRENCH SETTLES.
 2. TRACER WIRE TO HAVE SUFFICIENT SLACK BUNDLED INSIDE THE BOX TO THE SATISFACTION OF ENWIN.



VALVE SETTING ON A PVC WATERMAIN

DRAWN BY:	CHECKED BY:	APPROVED BY:	REVISION DATE:	DWG. NO.:
	V.S.	N.P.	NOV. 2024	50.03.01

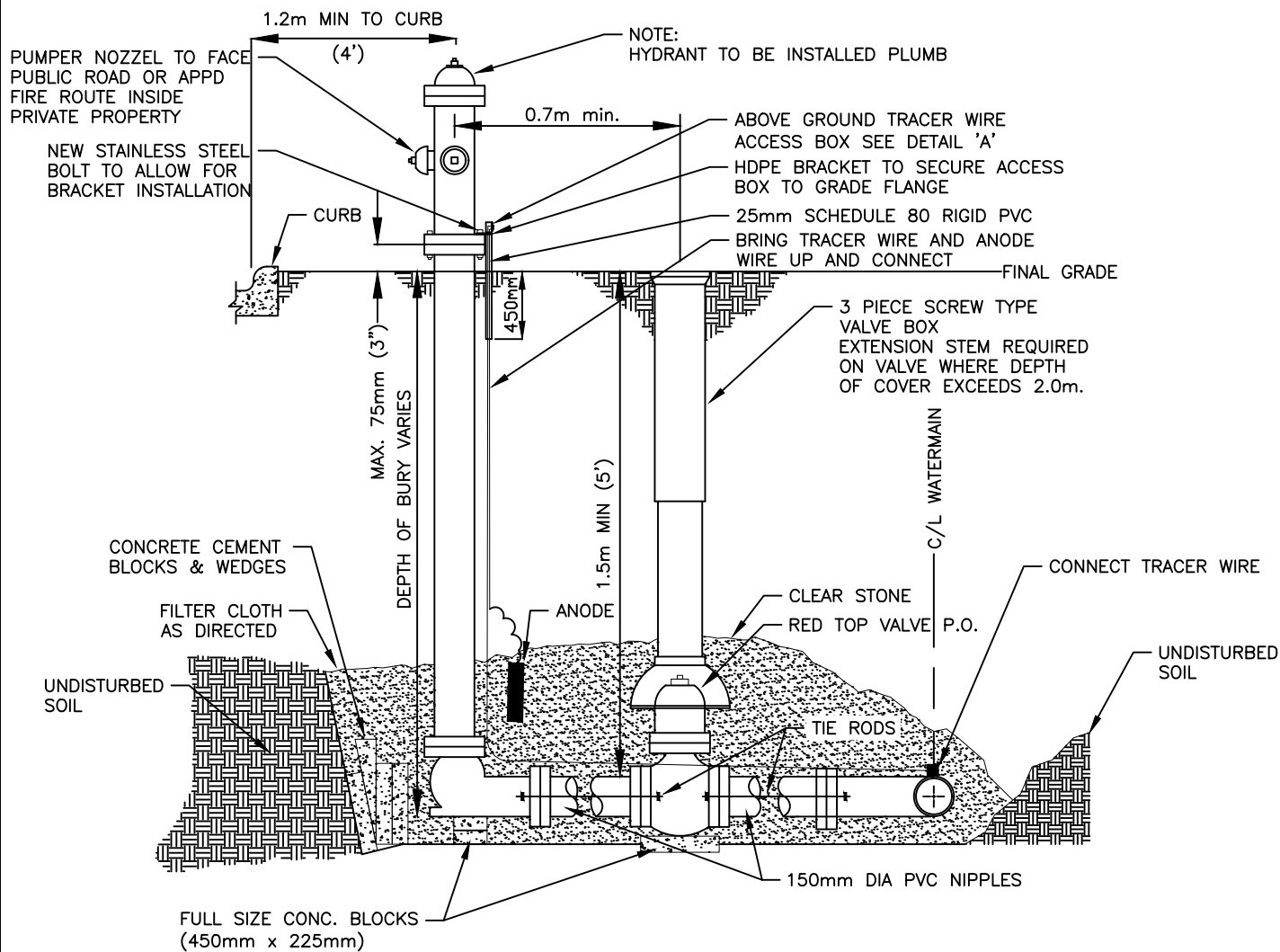

NOTES:

1. ALL STEEL BOLTS AND TIE RODS TO BE CAPPED WITH SAC CAPS.
2. ALL HYDRANTS ON PUBLIC R.O.W. SHALL BE FLOW TESTED, COLOUR CODED AND PAINTED AS PER WUC STD DWG 50.04.03

DETAIL 'A'

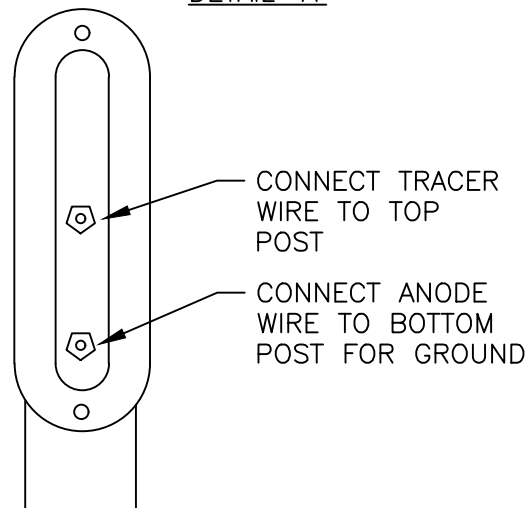

COBRA T2 TEST STATION

FIRE HYDRANT INSTALLATION WITH TEE AND VALVE

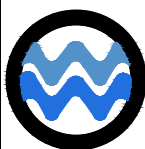

**WINDSOR
UTILITIES
COMMISSION**

DRAWN BY:

CHECKED BY:

APPROVED BY:

REVISION DATE:

DWG. NO.:

V.S.

N.P.

NOVEMBER 2021

50.04.01

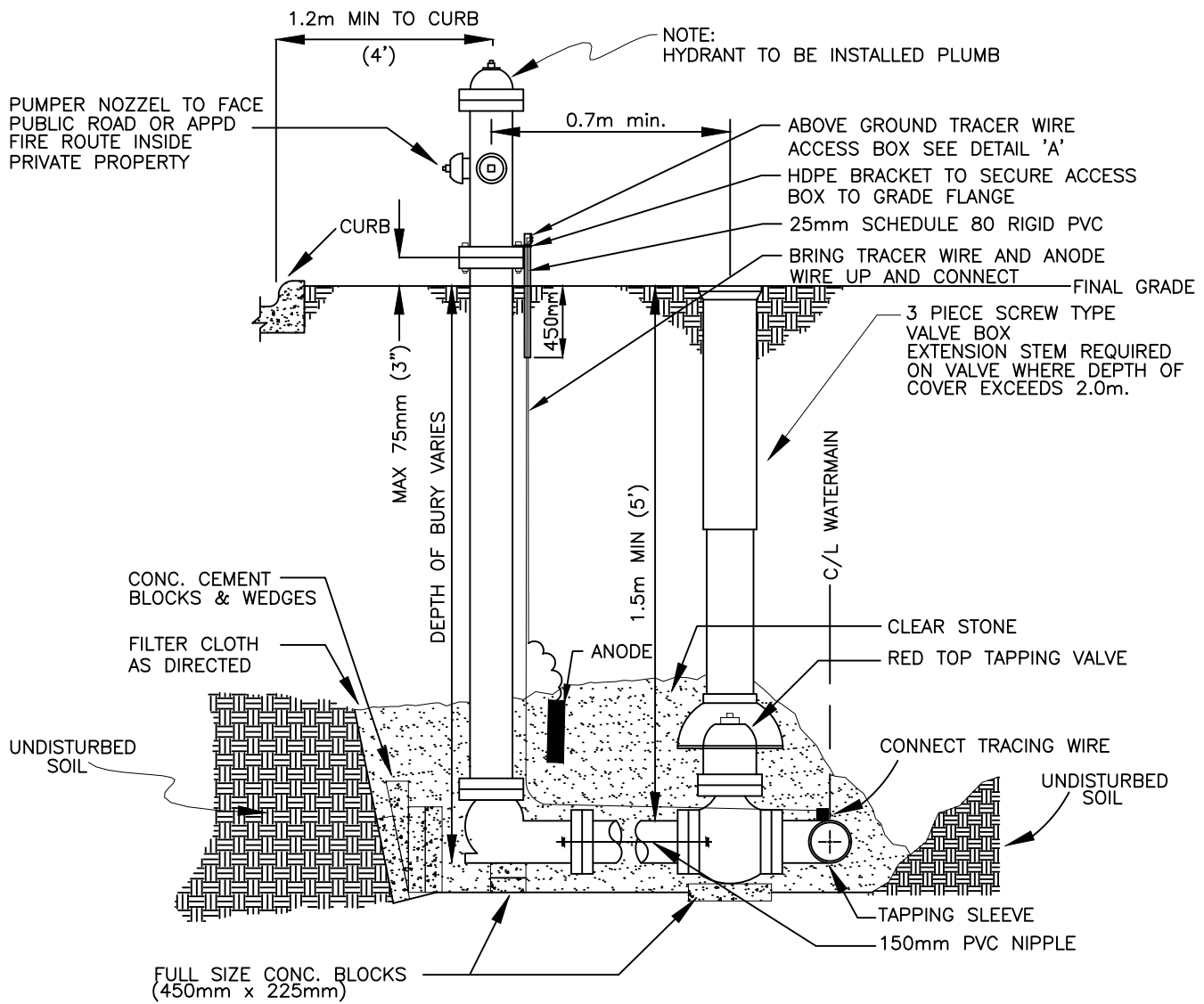

- NOTES:
1. ALL STEEL BOLTS AND TIE RODS TO BE CAPPED WITH SAC CAPS.
 2. ALL HYDRANTS ON PUBLIC R.O.W. SHALL BE FLOW TESTED, COLOUR CODED AND PAINTED AS PER WUC STD DWG 50.04.03

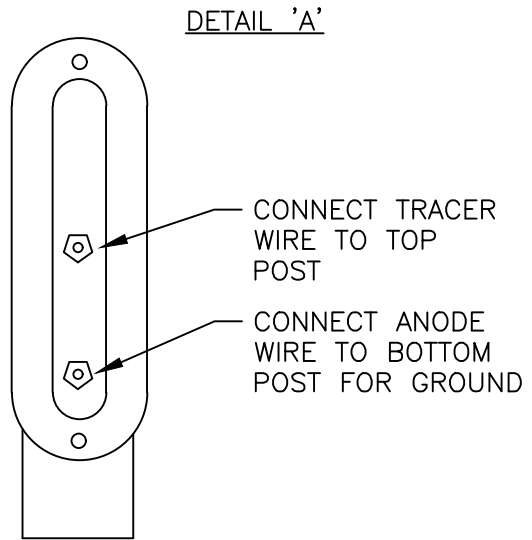

COBRA T2 TEST STATION

FIRE HYDRANT INSTALLATION WITH TAPPING VALVE



DRAWN BY:	CHECKED BY: V.S.	APPROVED BY: N.P.	REVISION DATE: NOVEMBER 2021	DWG. NO.: 50.04.02
-----------	---------------------	----------------------	---------------------------------	------------------------------

HYDRANT COLOUR CODE

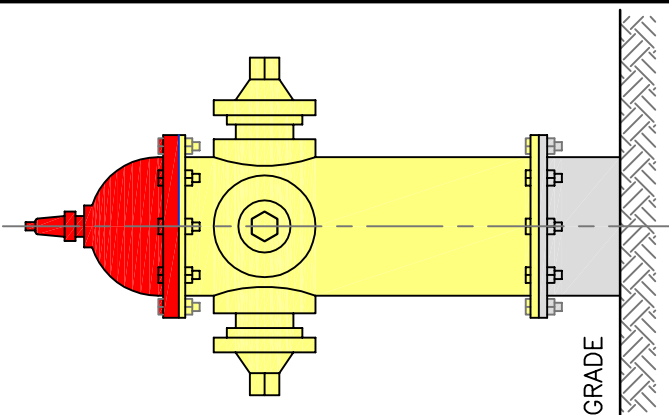
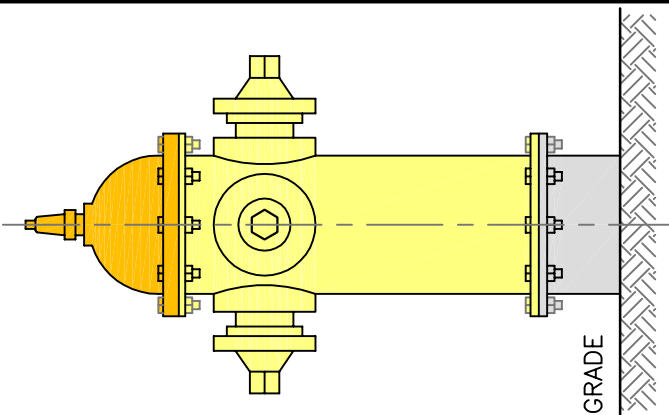
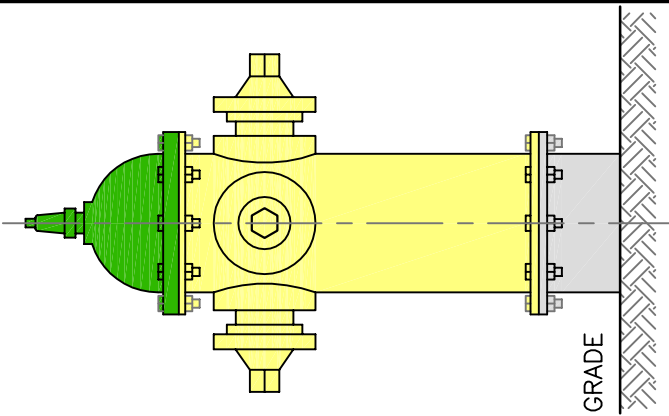
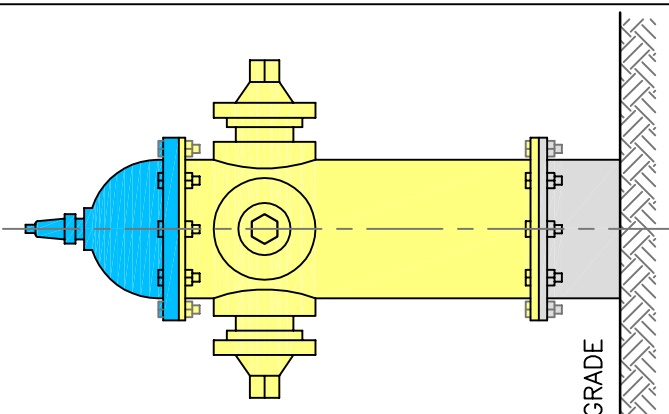
<p>499 G.P.M (US) OR LESS (RED)</p>	<p>500-999 G.P.M.(US) (ORANGE)</p>	<p>1000-1499 G.P.M. (US) (GREEN)</p>	<p>1500 G.P.M. (US) OR GREATER (LIGHT BLUE)</p>
			
<p>CLASS 'C'</p>	<p>CLASS 'B'</p>	<p>CLASS 'A'</p>	<p>CLASS 'A-A'</p>

*COLOUR CODING IS AS PER NFPA 291

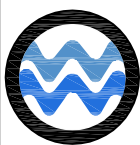

WINDSOR
UTILITIES
COMMISSION

HYDRANT COLOUR CODES

DRAWN BY:

CHECKED BY:

APPROVED BY:

REVISION DATE:

DWG. NO.:

V.S.

N.P.

JUNE 04/2010

50.04.03

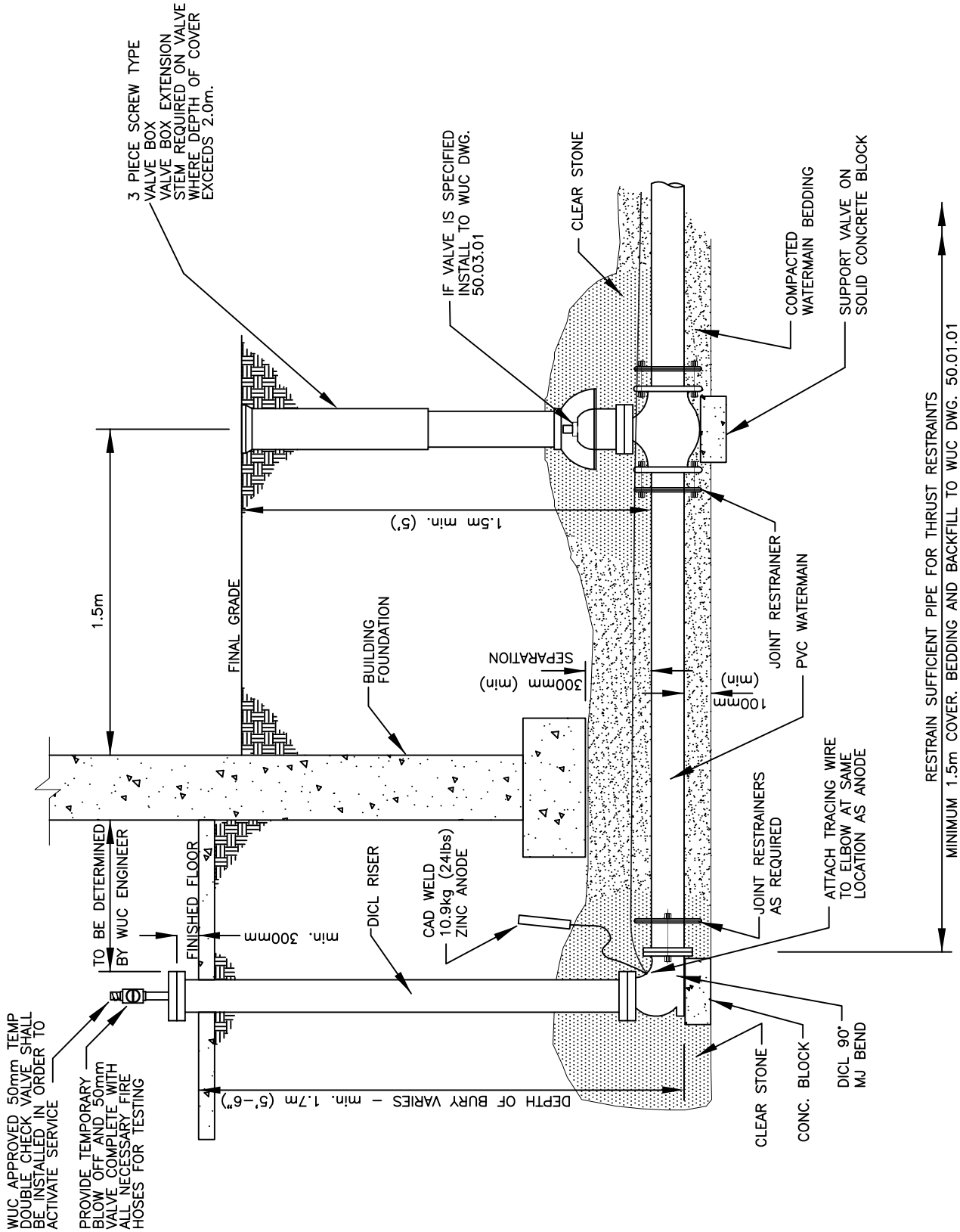

TYPICAL WATERMAIN UNDER BUILDING FOOTING DOMESTIC SERVICE ONLY

DRAWN BY:

CHECKED BY:

V.S.

APPROVED BY:

N.P.

REVISION DATE:

MARCH/2015

DWG. NO.:

50.05.01

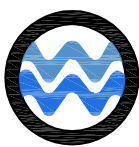
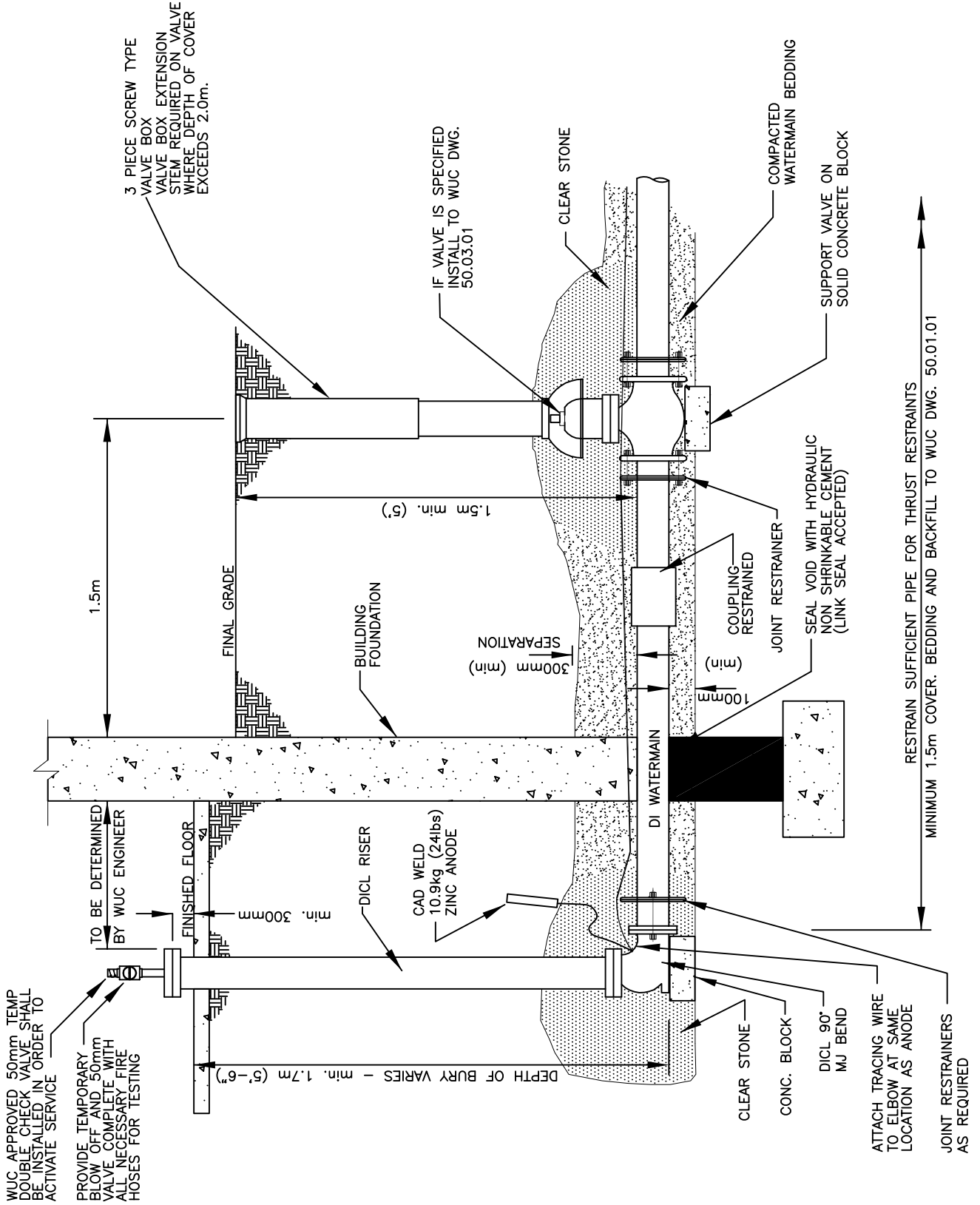

WINDSOR
UTILITIES
COMMISSION

TYPICAL WATERMAIN THROUGH BUILDING FOOTING DOMESTIC SERVICE ONLY

DRAWN BY:

CHECKED BY:

APPROVED BY:

REVISION DATE:

DWG. NO.:

V.S.

N.P.

MARCH/2015

50.05.02

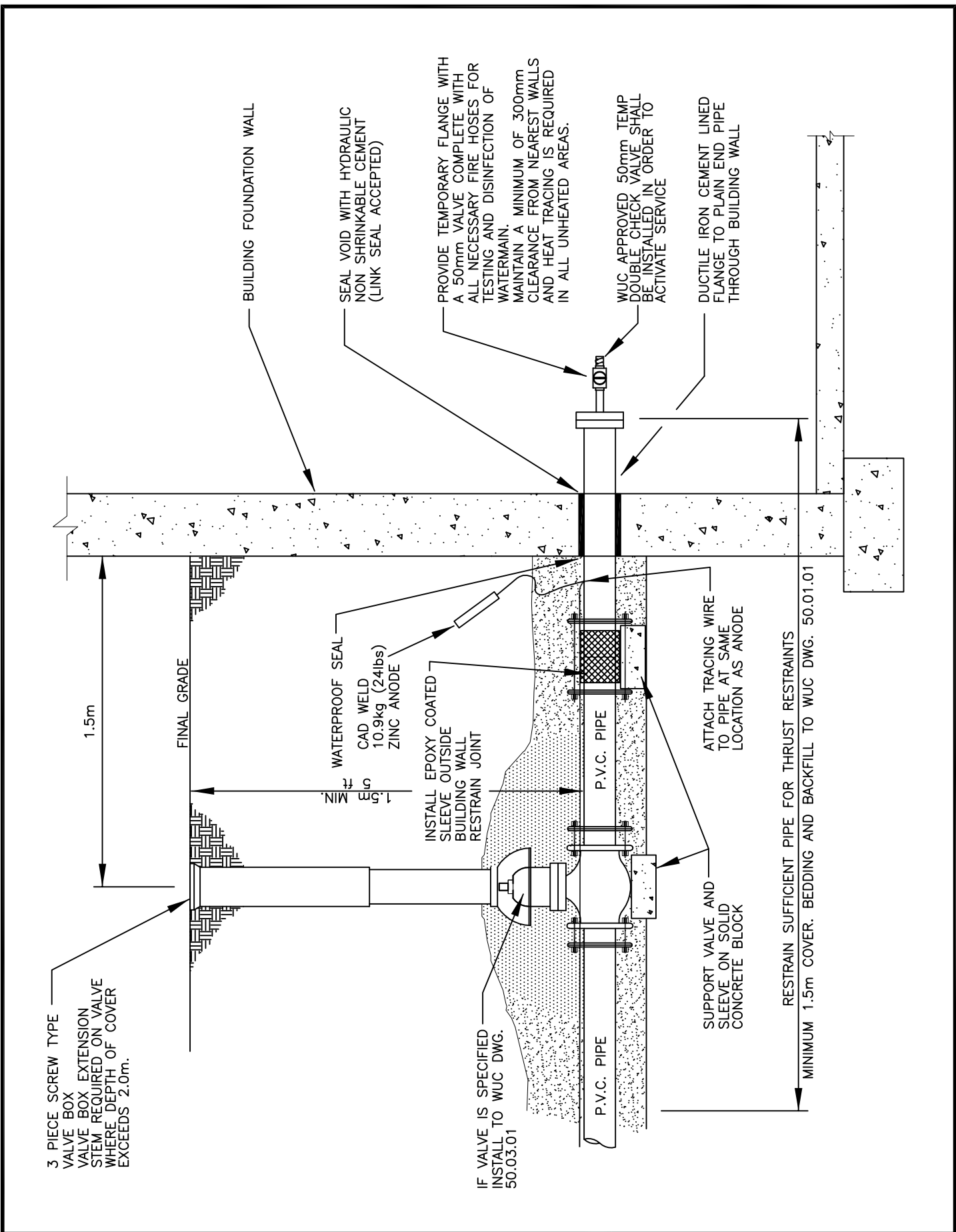

3 PIECE SCREW TYPE VALVE BOX EXTENSION STEM REQUIRED ON VALVE WHERE DEPTH OF COVER EXCEEDS 2.0m.

1.5m

FINAL GRADE

WATERPROOF SEAL
CAD WELD
10.9kg (24lbs)
ZINC ANODE

INSTALL EPOXY COATED SLEEVE OUTSIDE BUILDING WALL RESTRAIN JOINT

IF VALVE IS SPECIFIED INSTALL TO WUC DWG. 50.03.01

P.V.C. PIPE

P.V.C. PIPE

SUPPORT VALVE AND SLEEVE ON SOLID CONCRETE BLOCK

ATTACH TRACING WIRE TO PIPE AT SAME LOCATION AS ANODE

RESTRAIN SUFFICIENT PIPE FOR THRUST RESTRAINTS

MINIMUM 1.5m COVER. BEDDING AND BACKFILL TO WUC DWG. 50.01.01

BUILDING FOUNDATION WALL

SEAL VOID WITH HYDRAULIC NON SHRINKABLE CEMENT (LINK SEAL ACCEPTED)

PROVIDE TEMPORARY FLANGE WITH A 50mm VALVE COMPLETE WITH ALL NECESSARY FIRE HOSES FOR TESTING AND DISINFECTION OF WATERMAIN. MAINTAIN A MINIMUM OF 300mm CLEARANCE FROM NEAREST WALLS AND HEAT TRACING IS REQUIRED IN ALL UNHEATED AREAS.

WUC APPROVED 50mm TEMP DOUBLE CHECK VALVE SHALL BE INSTALLED IN ORDER TO ACTIVATE SERVICE

DUCTILE IRON CEMENT LINED FLANGE TO PLAIN END PIPE THROUGH BUILDING WALL



TYPICAL WATERMAIN THROUGH BUILDING WALL DOMESTIC SERVICE ONLY

DRAWN BY:	CHECKED BY:	APPROVED BY:	REVISION DATE:	DWG. NO.:
	V.S.	N.P.	MARCH/2015	50.05.03

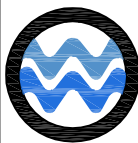
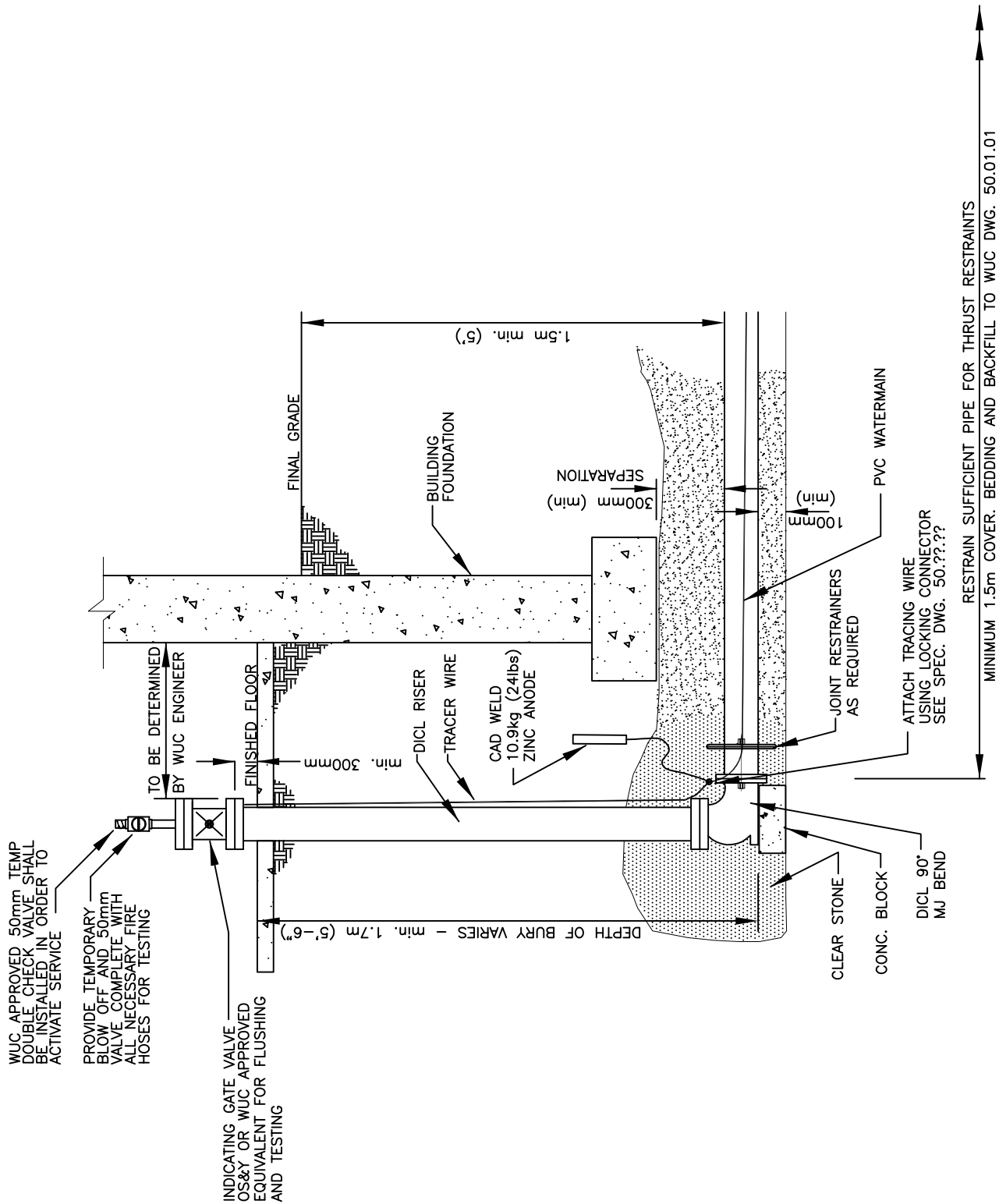

WINDSOR
UTILITIES
COMMISSION

TYPICAL WATERMAIN UNDER BUILDING FOOTING FIRE SERVICE ONLY

DRAWN BY:

CHECKED BY:

APPROVED BY:

REVISION DATE:

DWG. NO.:

V.S.

N.P.

JUNE 04/2010

50.05.04

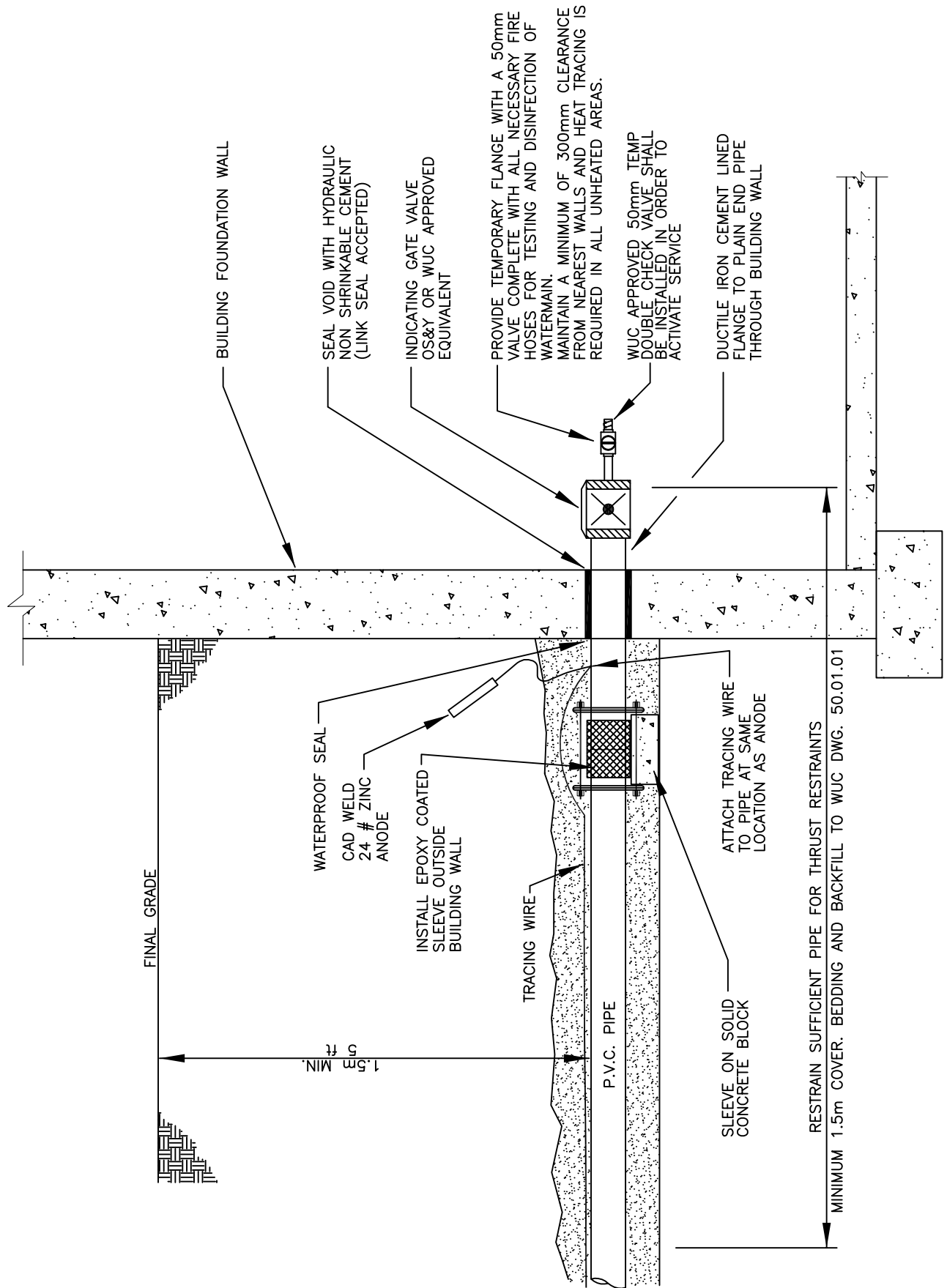

TYPICAL WATERMAIN THROUGH BUILDING WALL FIRE SERVICE ONLY

DRAWN BY:

CHECKED BY:

APPROVED BY:

REVISION DATE:

DWG. NO.:

V.S.

N.P.

JUNE 04/2010

50.05.05

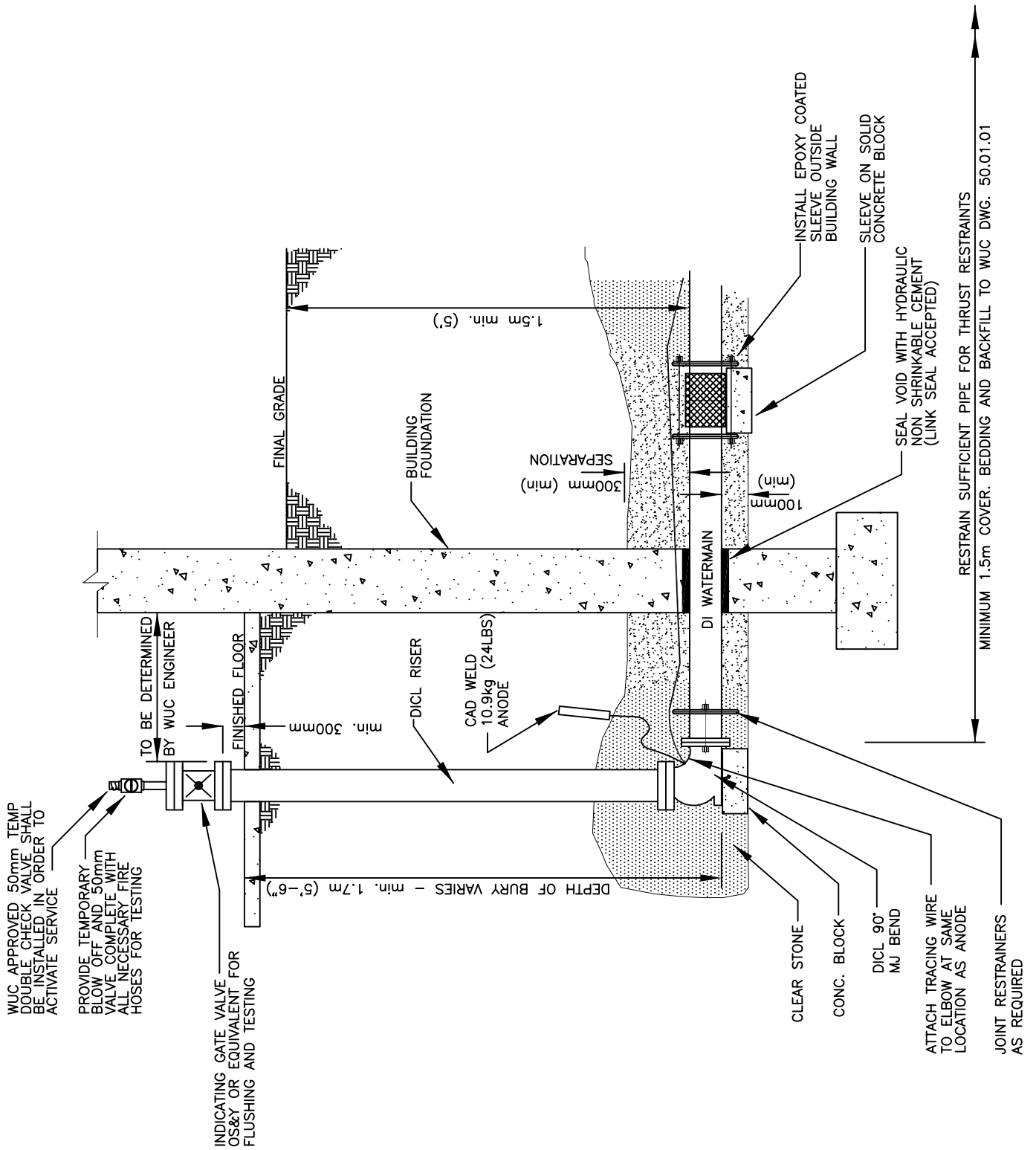

TYPICAL WATERMAIN THROUGH BUILDING FOOTING FIRE SERVICE ONLY

DRAWN BY:	CHECKED BY:	APPROVED BY:	REVISION DATE:	DWG. NO.:
	V.S.	N.P.	JUNE 04/2010	50.05.06

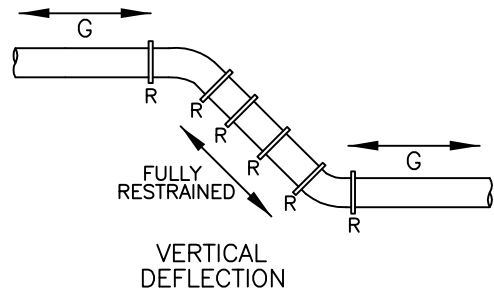
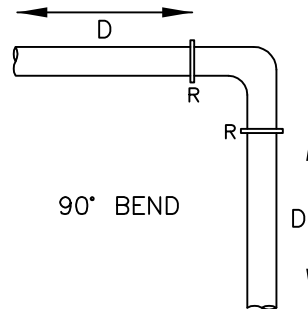
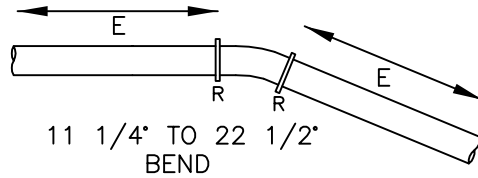
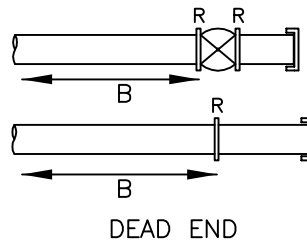
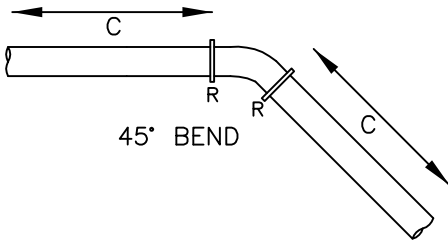
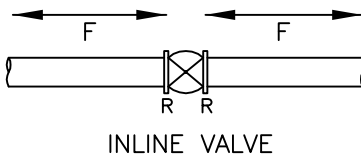
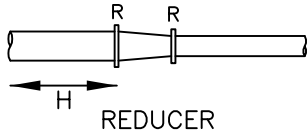
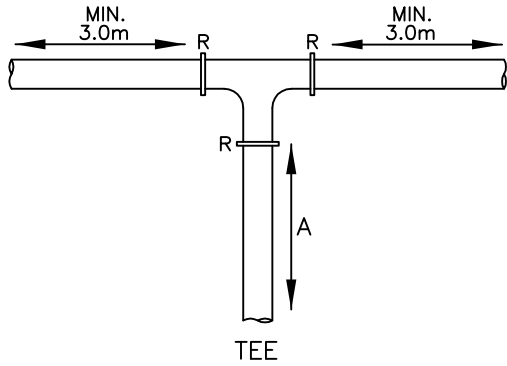

PVC PIPE THRUST RESTRAINT										
MIN. LENGTH OF PVC WM. TO BE RESTRAINED (m)										
PIPE DIA. / LENGTH	100mm (4")	150mm (6")	200mm (8")	250mm (10")	300mm (12")	350mm (14")	400mm (16")	450mm (18")	500mm (20")	600mm (24")
A	0.0	0.0	3.0	6.0	9.0	12.0	15.0	18.0	21.0	27.0
B	9.0	12.0	15.0	18.0	21.0	24.0	27.0	30.0	33.0	39.0
C	3.0	3.0	3.0	6.0	6.0	6.0	6.0	6.0	9.0	9.0
D	6.0	6.0	9.0	9.0	12.0	12.0	15.0	15.0	18.0	21.0
E	3.0	3.0	3.0	3.0	3.0	3.0	3.0	3.0	6.0	6.0
F	3.0	6.0	6.0	9.0	9.0	12.0	12.0	15.0	15.0	18.0
G	3.0	6.0	6.0	9.0	9.0	12.0	12.0	15.0	15.0	18.0
H	0.0	6.0	6.0	6.0	6.0	6.0	12.0	12.0	12.0	12.0

NOTE:

- 'R' DENOTES RESTRAINT DEVICE
- RESTRAINT LENGTHS BASED ON 'CL' TYPE SOIL CONDITIONS TYPICALLY FOUND AT A DEPTH OF 1.5 METERS. REFER TO ASTM D2487 FOR COMPLETE DESCRIPTION. IN AREAS WHERE SAND IS PREVALENT OR PIPE IS SITUATED BELOW WATER TABLE, RESTRAINED LENGTHS WILL BE DETERMINED BY THE ENGINEER.
- REDUCER DIMENSION 'H' ASSUMES ONE REDUCTION IN PIPE SIZE. IF REDUCTION IS GREATER THAN ONE PIPE SIZE, RESTRAINED LENGTH WILL BE DETERMINED BY THE ENGINEER.

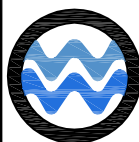

**WINDSOR
UTILITIES
COMMISSION**

**PVC PIPE JOINT
THRUST RESTRAINT**

DRAWN BY:

CHECKED BY:

APPROVED BY:

REVISION DATE:

DWG. NO.:

V.S.

N.P.

JUNE 04/2010

50.06.01

- NOTE:**
- 1) KEEP FACE OF STEEL AWAY FROM FITTINGS TO AVOID DAMAGE TO FITTINGS DURING INSTALLATION.
 - 2) BEAMS TO BE DRIVEN INTO SOLID UNDISTURBED SOIL TO SUFFICIENT DEPTH TO WITHSTAND A PRESSURE OF 100 PSI.
 - 3) WHEN TYPE 4 SOILS ARE ENCOUNTERED BEAM SIZE AND LENGTH TO BE DESIGNED BY AN ENGINEER.

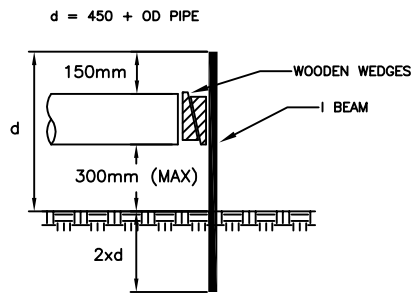
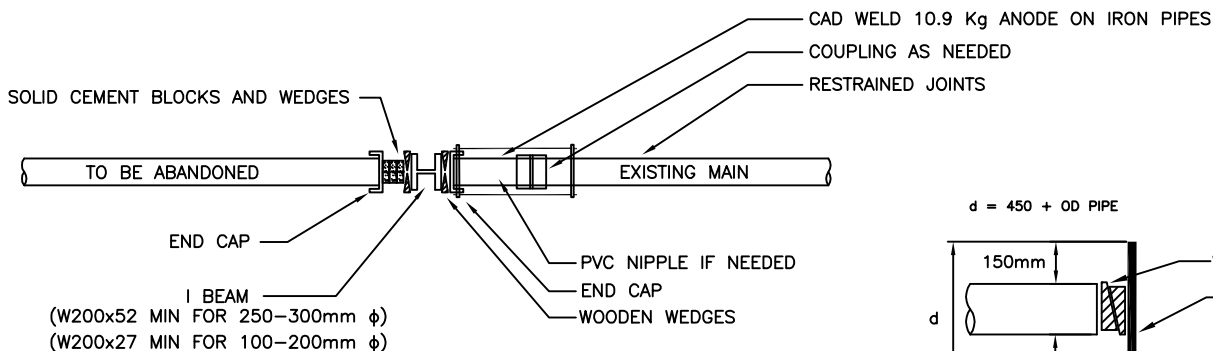
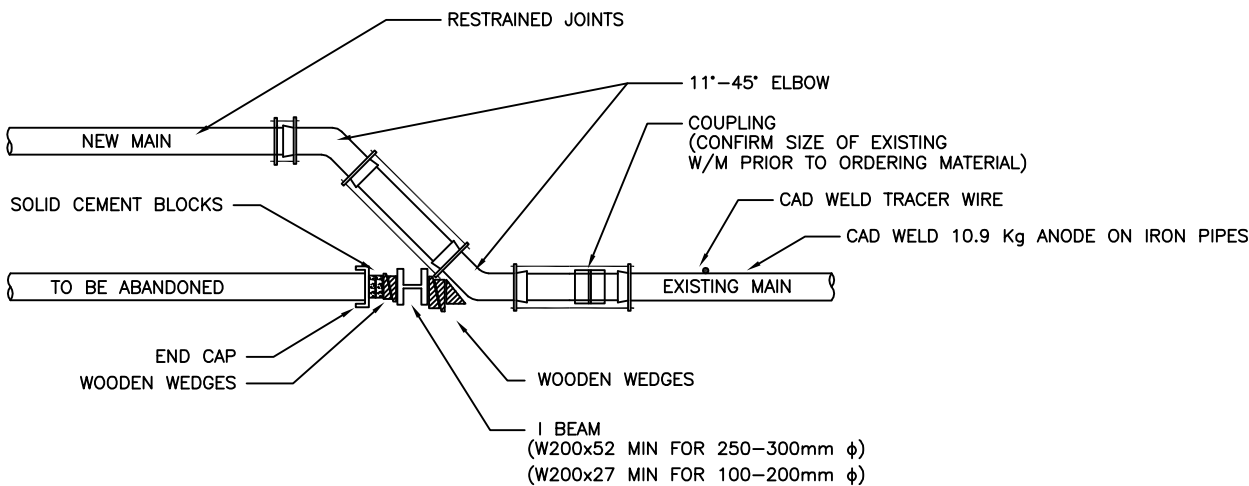
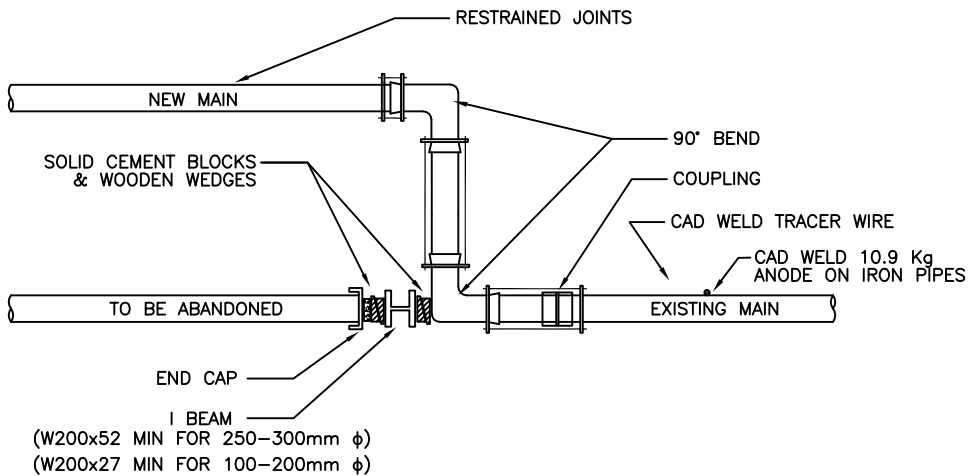

PROFILE



TIE IN DETAILS AND THRUST BLOCKING

DRAWN BY: M.L.	CHECKED BY: V.S.	APPROVED BY: N.P.	REVISION DATE: OCT 31/2011	DWG. NO.: 50.06.02
-------------------	---------------------	----------------------	-------------------------------	-----------------------

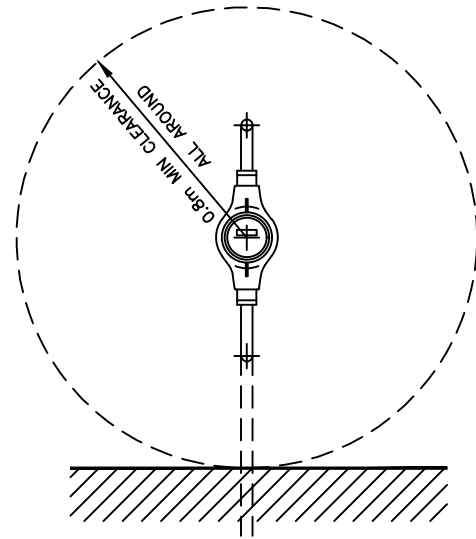
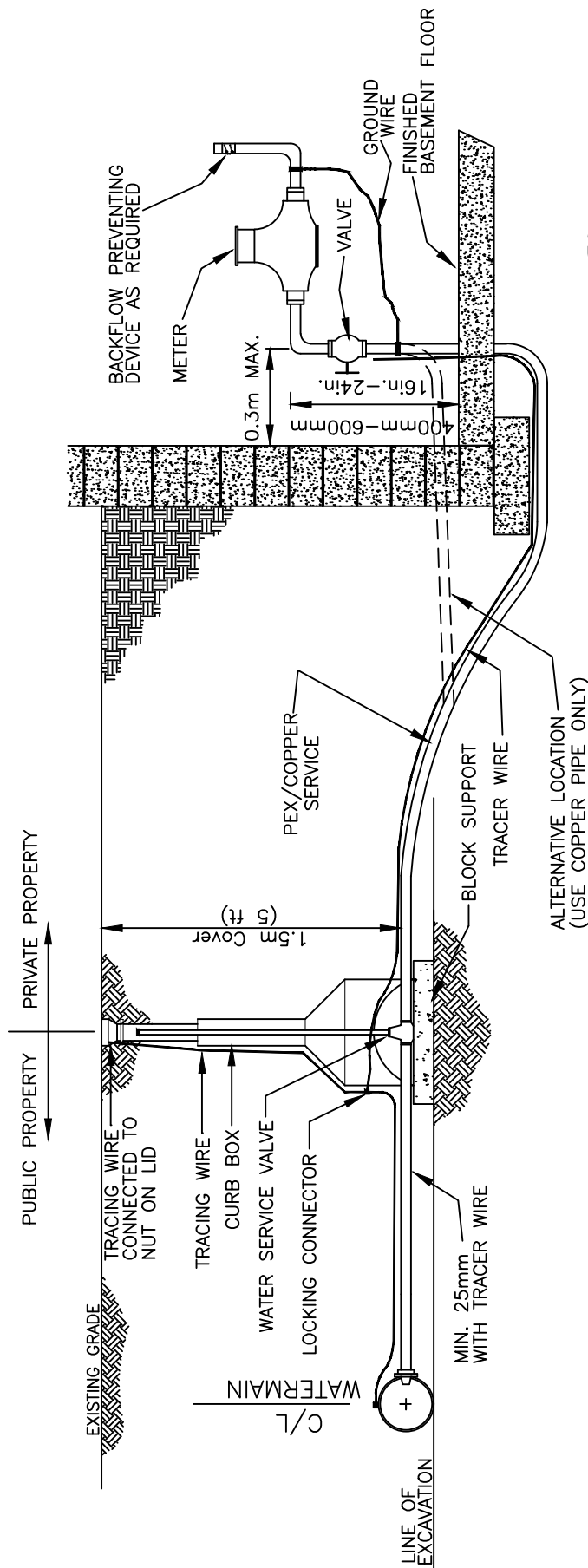

PLAN

NOTE:
 LOCATION OF WATER METER IN RELATION TO OTHER PERMANENT FIXTURES (FURNACE, WATER HEATER, ETC.) MUST ALLOW MINIMUM OF 0.8m (30") CLEARANCE NECESSARY FOR ANY FUTURE METER REPAIR OR REMOVAL.

WATER METER MUST NOT BE ENCLOSED WITHIN WALLS AND MUST REMAIN READILY ACCESSIBLE TO UTILITY PERSONNEL. WATER METER SHALL BE INSTALLED HORIZONTALLY ONLY.

100% SOLID CONCRETE BLOCKS SHALL BE USED TO BLOCK ALL WATER WORK MATERIALS. BLOCKING ANY WATER WORK MATERIALS WITH BRICKS WILL NOT BE ACCEPTED. CURB STOP VALVES SHALL BE BLOCKED WITH FULL-SIZE (4"x8"x16") CONCRETE BLOCKS WITH THE LONG SIDE OF THE BLOCK SET PERPENDICULAR TO THE WATER SERVICE LINE. SERVICE COUPLINGS (75mm DIA. AND SMALLER) SHALL BE BLOCKED WITH HALF-SIZE (4"x8"x8") CONCRETE BLOCKS.



TYPICAL WATER SERVICE AND METER INSTALLATION FOR METER ROOM APPLICATIONS

DRAWN BY:
B.J.O.

CHECKED BY:
S.J.

APPROVED BY:
C.M.

REVISION DATE:
NOV. 2024

DWG. NO.:
50.07.01

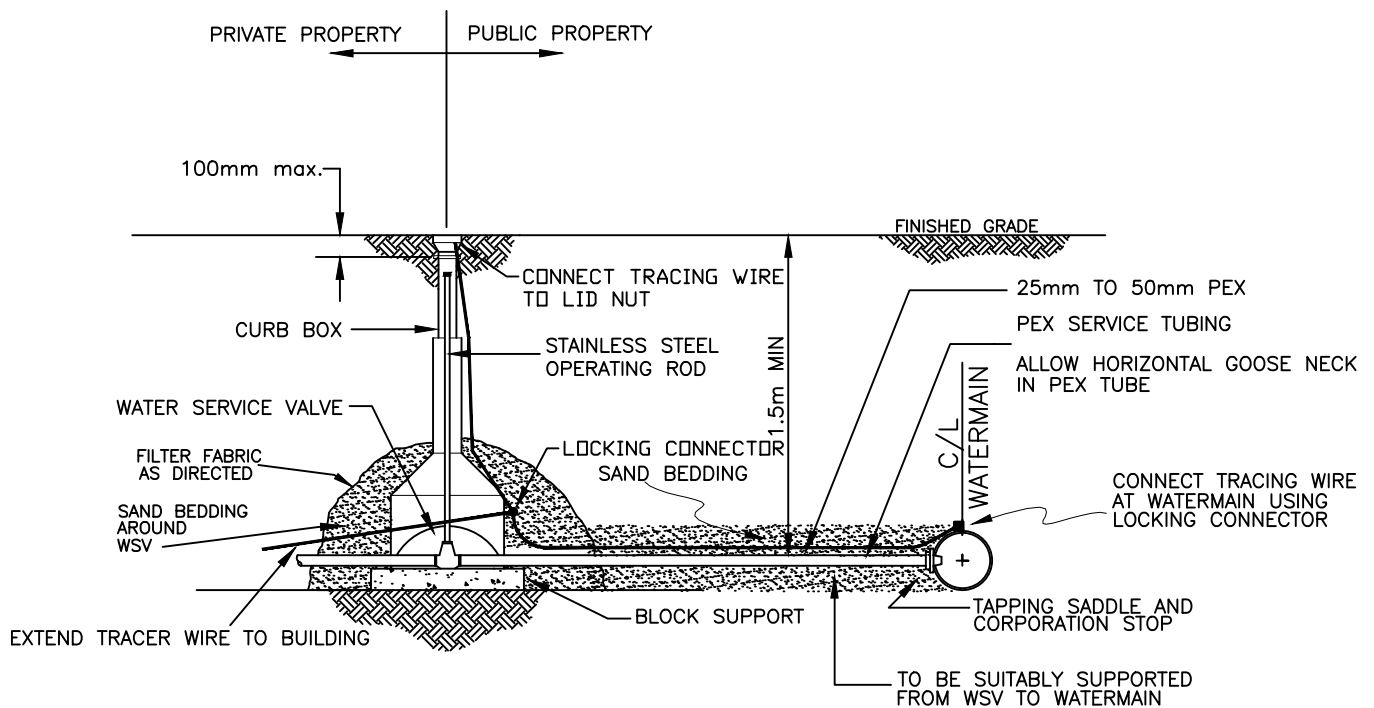
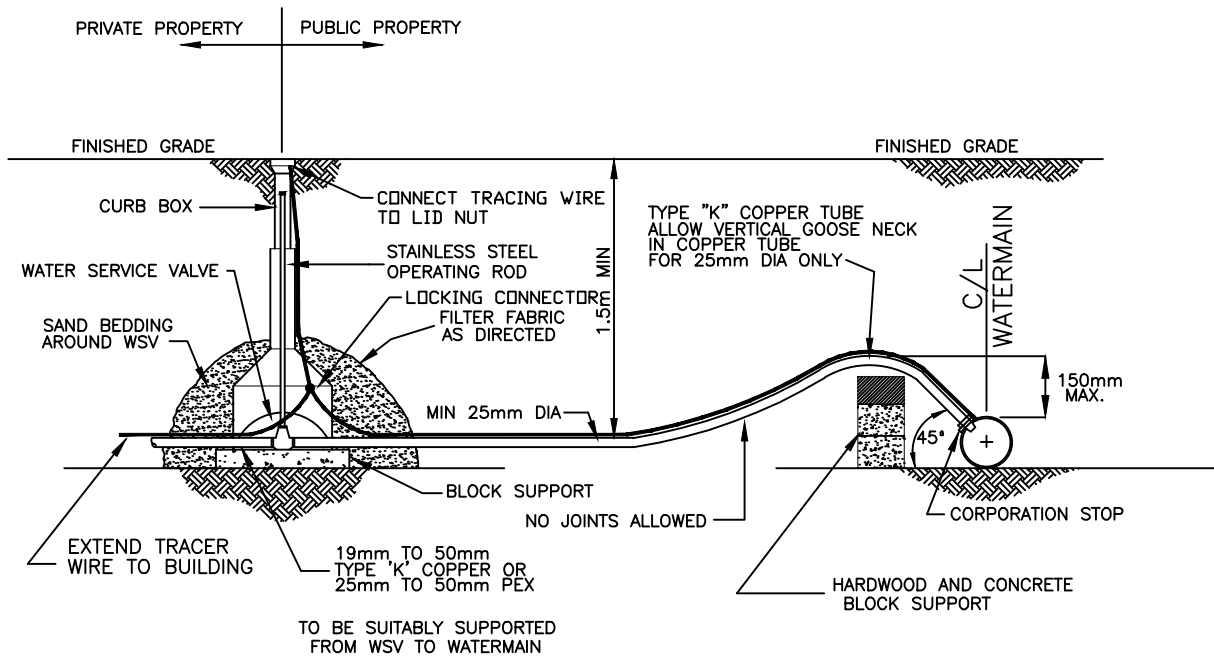

NOTE:
IT IS WUC PRACTICE TO USE AWWA TAPER THREAD ON ALL SERVICE TAPS UP TO 50mm.

100% SOLID CONCRETE BLOCKS SHALL BE USED TO BLOCK ALL WATER WORK MATERIALS. BLOCKING ANY WATER WORK MATERIALS WITH BRICKS WILL NOT BE ACCEPTED. CURB STOP VALVES SHALL BE BLOCKED WITH FULL-SIZE (4"x8"x16") CONCRETE BLOCKS WITH THE LONG SIDE OF THE BLOCK SET PERPENDICULAR TO THE WATER SERVICE LINE. SERVICE COUPLINGS (75mm DIA. AND SMALLER) SHALL BE BLOCKED WITH HALF-SIZE (4"x8"x8") CONCRETE BLOCKS.

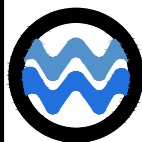

**WINDSOR
UTILITIES
COMMISSION**

COPPER/PEX SERVICE CONNECTIONS MAIN TO PROPERTY LINE

DRAWN BY:

CHECKED BY:

APPROVED BY:

REVISION DATE:

DWG. NO.:

V.S.

N.P.

OCT. / 2016

50.07.02

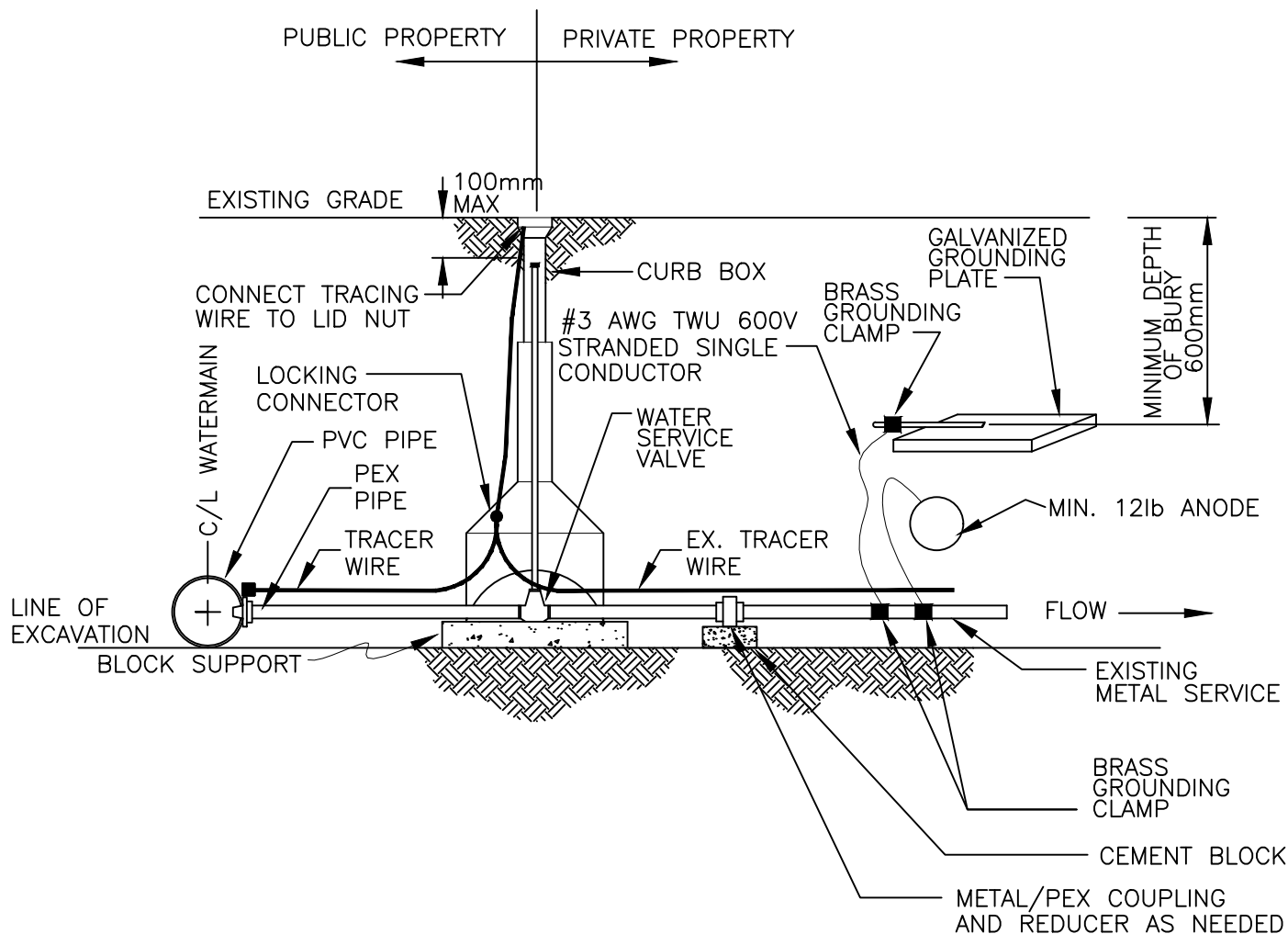

NOTE:
GROUNDING AND ANODE IS NOT REQUIRED ON EXISTING PE SERVICES.

100% SOLID CONCRETE BLOCKS SHALL BE USED TO BLOCK ALL WATER WORK MATERIALS. BLOCKING ANY WATER WORK MATERIALS WITH BRICKS WILL NOT BE ACCEPTED. CURB STOP VALVES SHALL BE BLOCKED WITH FULL-SIZE (4"x8"x16") CONCRETE BLOCKS WITH THE LONG SIDE OF THE BLOCK SET PERPENDICULAR TO THE WATER SERVICE LINE. SERVICE COUPLINGS (75mm DIA. AND SMALLER) SHALL BE BLOCKED WITH HALF-SIZE (4"x8"x8") CONCRETE BLOCKS.

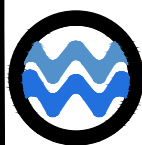

WINDSOR
UTILITIES
COMMISSION

WATER SERVICE CONNECTION TO EXISTING METAL SERVICE IN PRIVATE PROPERTY

DRAWN BY:

CHECKED BY:

APPROVED BY:

REVISION DATE:

DWG. NO.:

V.S.

N.P.

NOV. 2024

50.07.03

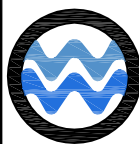

WINDSOR
UTILITIES
COMMISSION

WATER SERVICE TRANSFER INSTALLATION

DRAWN BY:

CHECKED BY:

V.S.

APPROVED BY:

N.P.

REVISION DATE:

JUNE 04/2010

DWG. NO.:

50.07.04

- NOTES:
- MINIMUM 0.6m SAND BEDDING AND BACKFILL ATOP WATER SERVICES
 - FULL GRANULAR BACKFILL TO CITY OF WINDSOR SPECS.
 - ANODES TO BE PLACED AT LEAST 1.0m AWAY FROM SERVICES AND AS DEEP AS BOTTOM OF SERVICE. ANODE CONNECTED TO COPPER PIPE WITH BRASS CLAMP AND ANODE WIRE CONNECTOR, MASTIC WRAP CONNECTOR.
 - STAINLESS STEEL SADDLES TO BE INSTALLED AND TAPS TO BE HORIZONTAL.
 - TRACING WIRE TO BE CONNECTED TO MAIN LINE TRACING WIRE AND EXTENDED AND CLAMPED TO EXIST. COPPER WATER SERVICE PIPE. ALL BRASS CLAMPS AND CONNECTORS TO BE MASTIC WRAPPED.
 - HORIZONTAL GOOSE NECKS TO BE USED.
 - ALL MATERIALS TO MEET W.U.C. SPECIFICATIONS.
 - INSTALLATION TO CONFORM TO W.U.C. SPECIFICATIONS. W.U.C. PROCEDURES MUST BE STRICTLY ADHERED TO.
 - SPECIAL ATTENTION MUST BE GIVEN TO COMPLY WITH THE ONTARIO HYDRO INSPECTION CODE.
 - NO WATER SERVICE SHOULD BE CUT WITHOUT FIRST INSTALLING A TEMPORARY JUMPER CONNECTION.

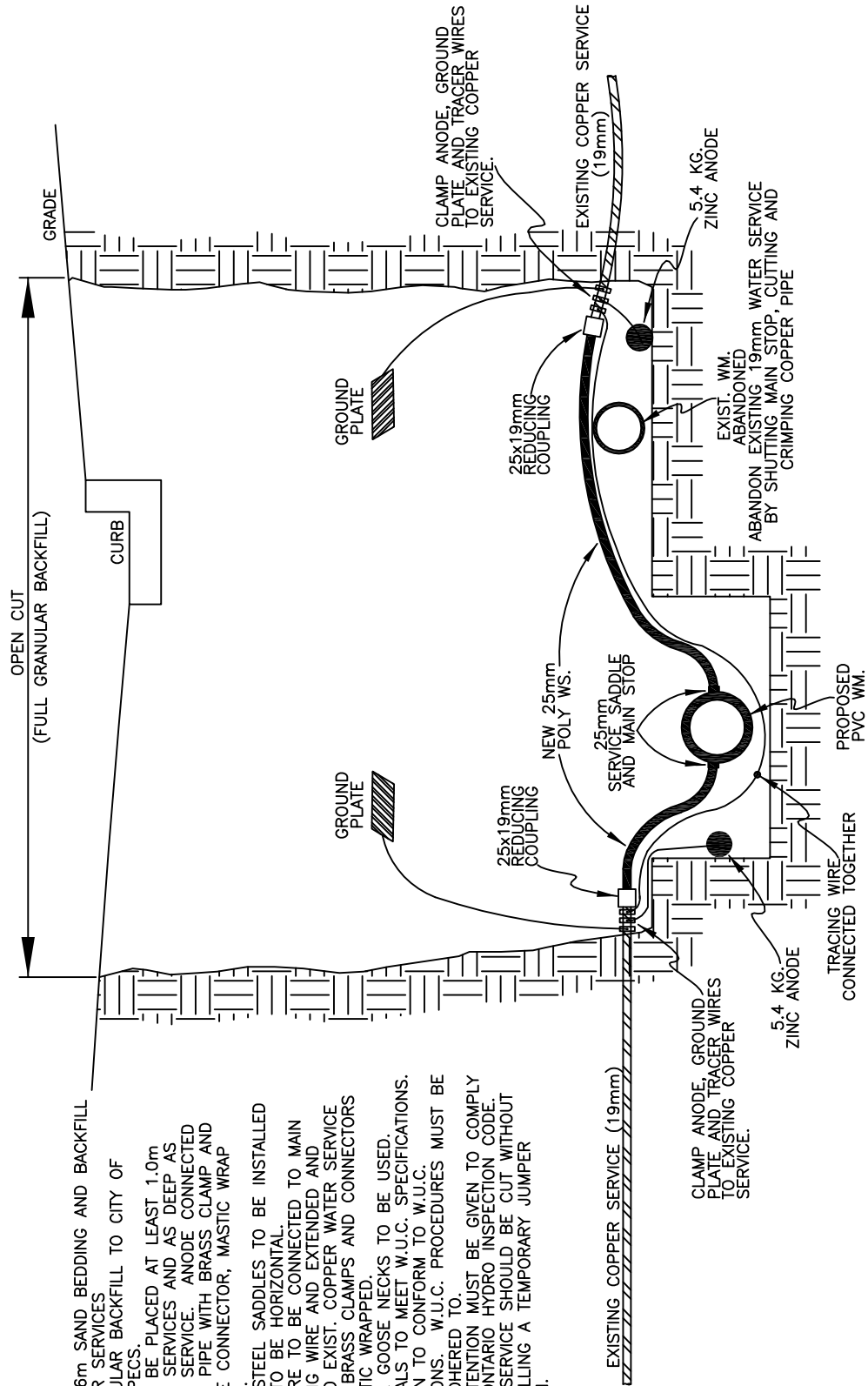

- NOTES:
- MINIMUM 0.6m SAND BEDDING AND BACKFILL ATOP WATER SERVICES
 - FULL GRANULAR BACKFILL TO CITY OF WINDSOR SPECS.
 - ANODES TO BE PLACED AT LEAST 1.0m AWAY FROM SERVICES AND AS DEEP AS BOTTOM OF SERVICE. ANODE CONNECTED TO COPPER PIPE WITH BRASS CLAMP AND ANODE WIRE CONNECTOR, MASTIC WRAP CONNECTOR.
 - STAINLESS STEEL SADDLES TO BE INSTALLED AND TAPS TO BE HORIZONTAL.
 - TRACING WIRE TO BE CONNECTED TO MAIN LINE TRACING WIRE AND EXTENDED AND CLAMPED TO EXIST. COPPER WATER SERVICE PIPE. ALL BRASS CLAMPS AND CONNECTORS TO BE MASTIC WRAPPED.
 - HORIZONTAL GOOSE NECKS TO BE USED.
 - ALL MATERIALS TO MEET W.U.C. SPECIFICATIONS.
 - INSTALLATION TO CONFORM TO W.U.C. SPECIFICATIONS. W.U.C. PROCEDURES MUST BE STRICTLY ADHERED TO.
 - SPECIAL ATTENTION MUST BE GIVEN TO COMPLY WITH THE ONTARIO HYDRO INSPECTION CODE.
 - NO WATER SERVICE SHOULD BE CUT WITHOUT FIRST INSTALLING A TEMPORARY JUMPER CONNECTION.

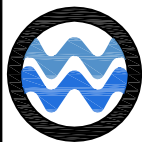
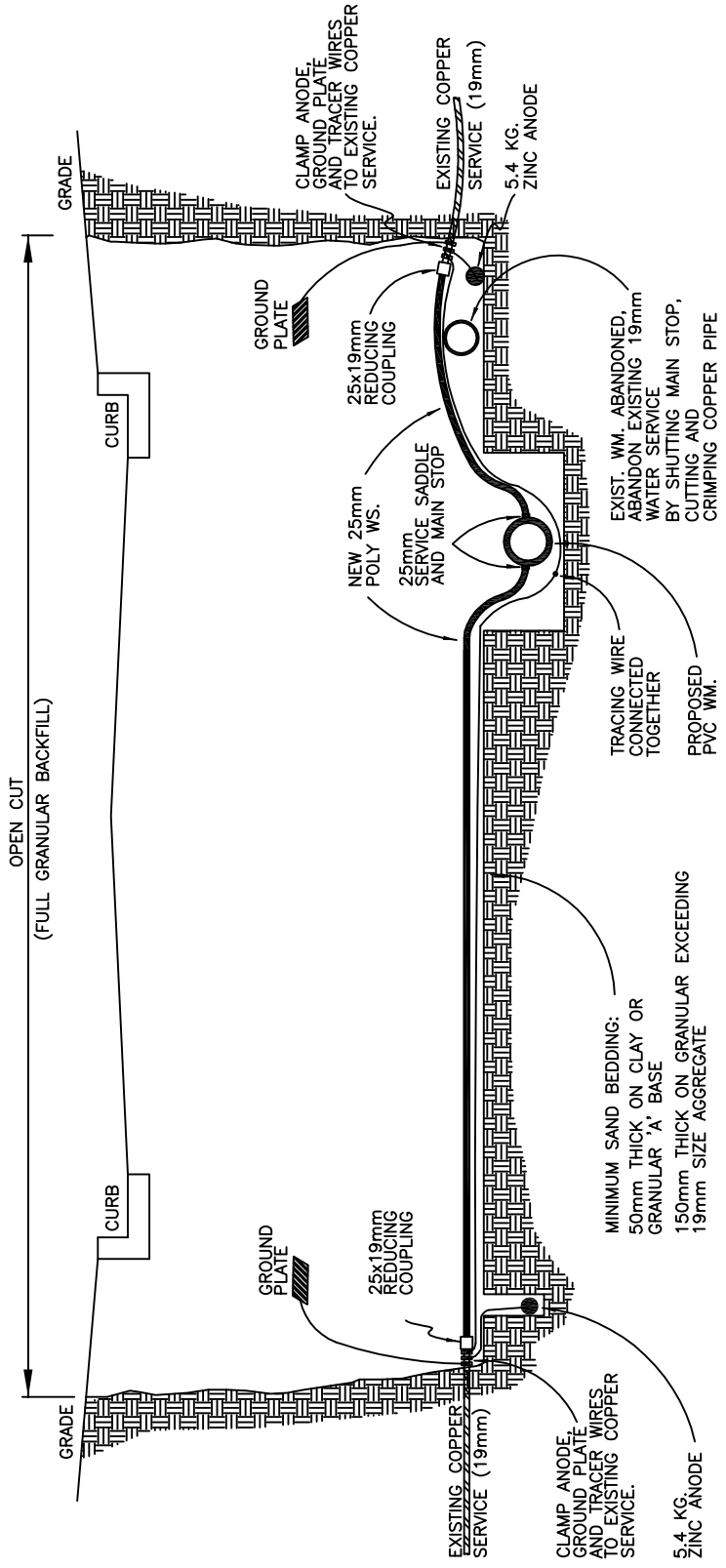

**WINDSOR
UTILITIES
COMMISSION**

WATER SERVICE TRANSFER INSTALLATION FULL STREET WIDTH

DRAWN BY:

CHECKED BY:

APPROVED BY:

REVISION DATE:

DWG. NO.:

V.S.

N.P.

JUNE 04/2010

50.07.05

- NOTES:
- MINIMUM 0.6m SAND BEDDING AND BACKFILL
 - TOP WATER SERVICES
 - FULL GRANULAR BACKFILL TO CITY OF WINDSOR SPECS.
 - ANODES TO BE PLACED AT LEAST 1.0m AWAY FROM SERVICES AND AS DEEP AS BOTTOM OF SERVICE. ANODE CONNECTED TO COPPER PIPE WITH BRASS CLAMP AND ANODE WIRE CONNECTOR, MASTIC WRAP CONNECTOR.
 - STAINLESS STEEL SADDLES TO BE INSTALLED AND TAPS TO BE HORIZONTAL.
 - TRACING WIRE TO BE CONNECTED TO MAIN LINE TRACING WIRE AND EXTENDED AND CLAMPED TO EXIST. COPPER WATER SERVICE PIPE. ALL BRASS CLAMPS AND CONNECTORS TO BE MASTIC WRAPPED.
 - HORIZONTAL GOOSE NECKS TO BE USED.
 - ALL MATERIALS TO MEET W.U.C. SPECIFICATIONS.
 - INSTALLATION TO CONFORM TO W.U.C. SPECIFICATIONS. W.U.C. PROCEDURES MUST BE STRICTLY ADHERED TO.
 - SPECIAL ATTENTION MUST BE GIVEN TO COMPLY WITH THE ONTARIO HYDRO INSPECTION CODE.
 - NO WATER SERVICE SHOULD BE CUT WITHOUT FIRST INSTALLING A TEMPORARY JUMPER CONNECTION.

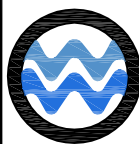
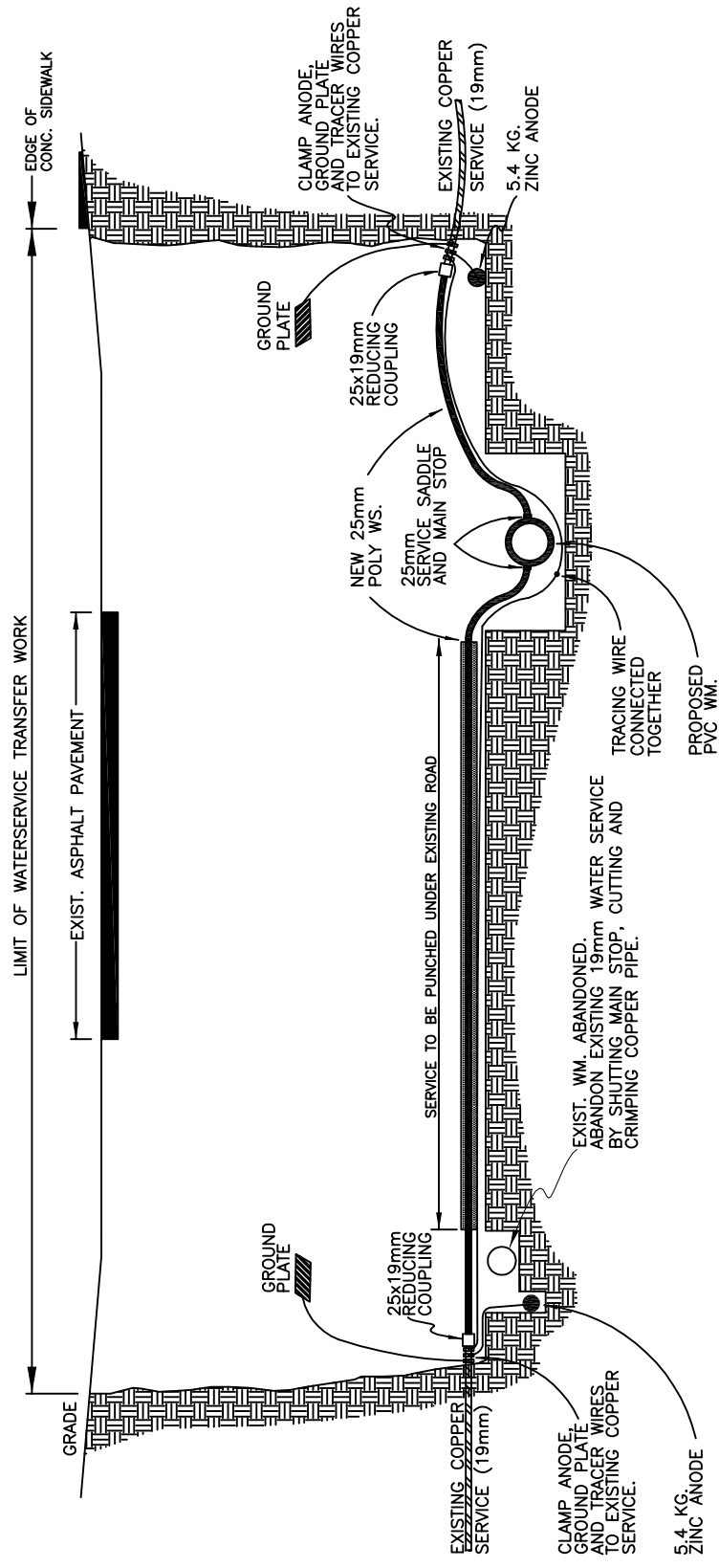

**WINDSOR
UTILITIES
COMMISSION**

WATER SERVICE TRANSFER INSTALLATION FULL STREET WIDTH

DRAWN BY:

CHECKED BY:

APPROVED BY:

REVISION DATE:

DWG. NO.:

V.S.

N.P.

JUNE 04/2010

50.07.06

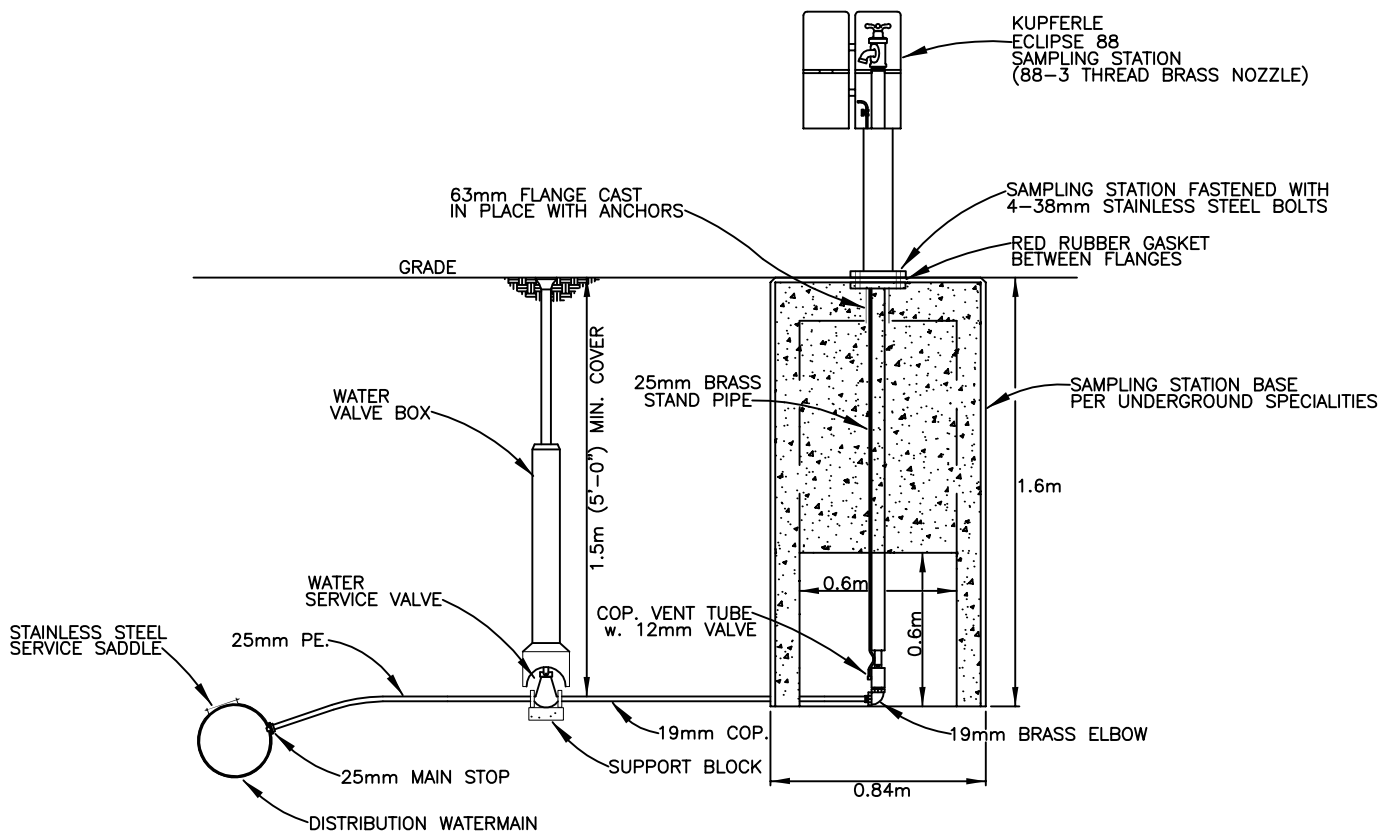

NOTE:
 ALL MATERIAL IN CONTACT WITH WATER
 SHALL BE NSF/ANSI 61 COMPLIANT



TYPICAL SAMPLING STATION INSTALLATION

DRAWN BY:

CHECKED BY:

V.S.

APPROVED BY:

N.P.

REVISION DATE:

JUNE 04/2010

DWG. NO.:

50.07.07

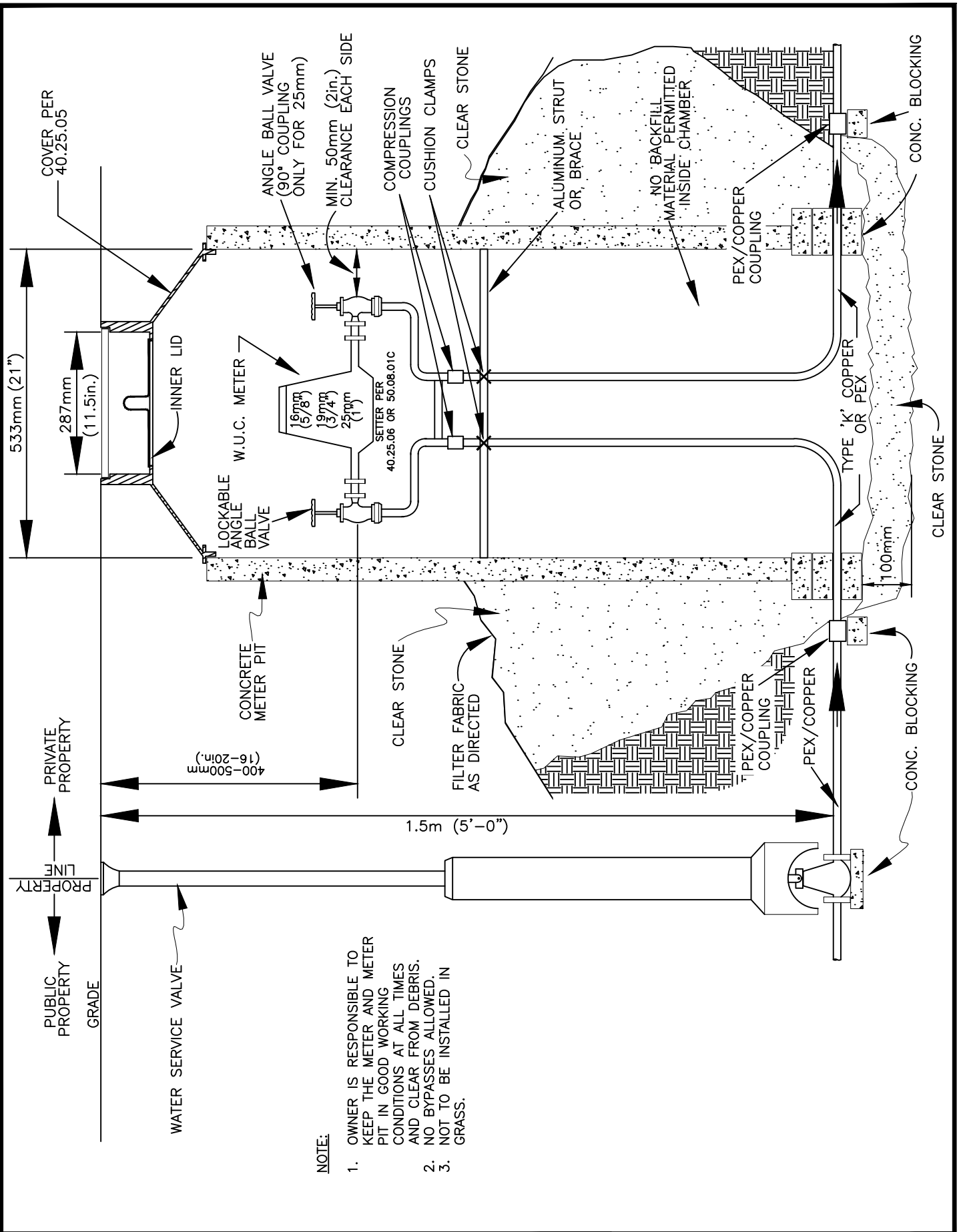

NOTE:

1. OWNER IS RESPONSIBLE TO KEEP THE METER AND METER PIT IN GOOD WORKING CONDITIONS AT ALL TIMES AND CLEAR FROM DEBRIS.
2. NO BYPASSES ALLOWED.
3. NOT TO BE INSTALLED IN GRASS.



CONCRETE METER PIT FOR 16mm, 19mm AND 25mm METERS IN DRIVEWAYS AND ROADS

DRAWN BY: B.J.O.	CHECKED BY: S.J.	APPROVED BY: C.M.	REVISION DATE: NOV. 2024
			DWG. NO.: 50.08.01A

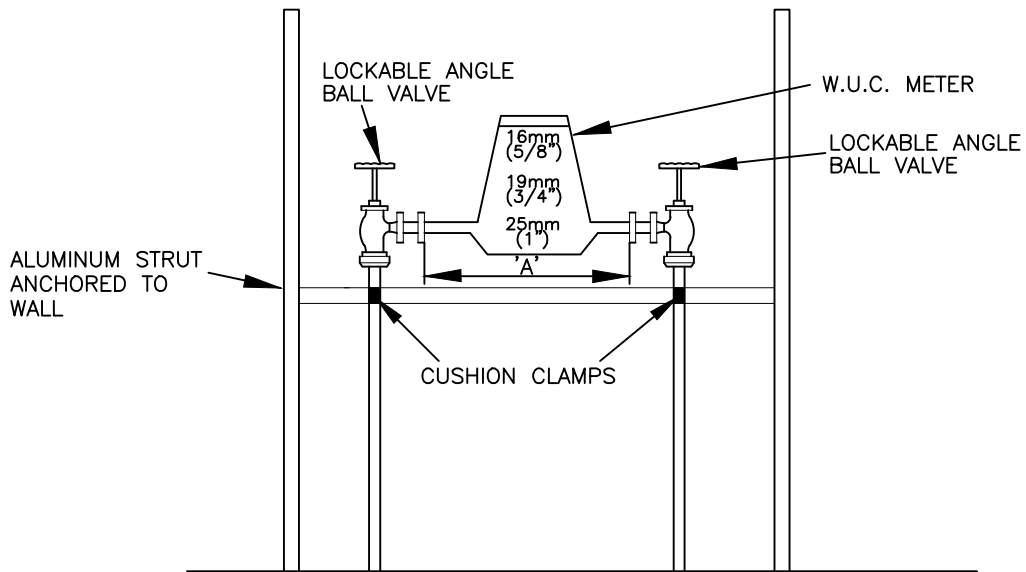

HAND-MADE METER
SETTER FOR CONCRETE
PITS ONLY

NOTE:

1. OWNER IS RESPONSIBLE TO KEEP THE METER AND METER PIT IN GOOD WORKING CONDITIONS AT ALL TIMES AND CLEAR FROM DEBRIS.
2. NO BYPASSES ALLOWED.
3. SETTER TO BE INSTALLED PER WUC DESIGN GUIDELINES AND SPECIFICATIONS ONLY.
4. IF ANY SETTER IS NOT INSTALLED PROPERLY THE WATER METER CAN NOT BE INSTALLED.
5. HAND-MADE SETTER TO BE ASSEMBLED USING ONLY THE PARTS SHOWN IN THIS DRAWING.

SPACING REQUIRED TO INSTALL METER	
METER SIZE	METER SPACING ('A')
5/8"x3/4" (16mm)	7.5" (190.5mm)
3/4" (19mm)	9.25" (235mm)
1" (25mm)	11" (279mm)



**HAND-MADE METER SETTER FOR
16mm, 19mm, AND 25mm WATER METERS**

DRAWN BY:
B.J.O.

CHECKED BY:
S.J.

APPROVED BY:
C.M.

REVISION DATE:
NOV. 2024

DWG. NO.:
50.08.01B

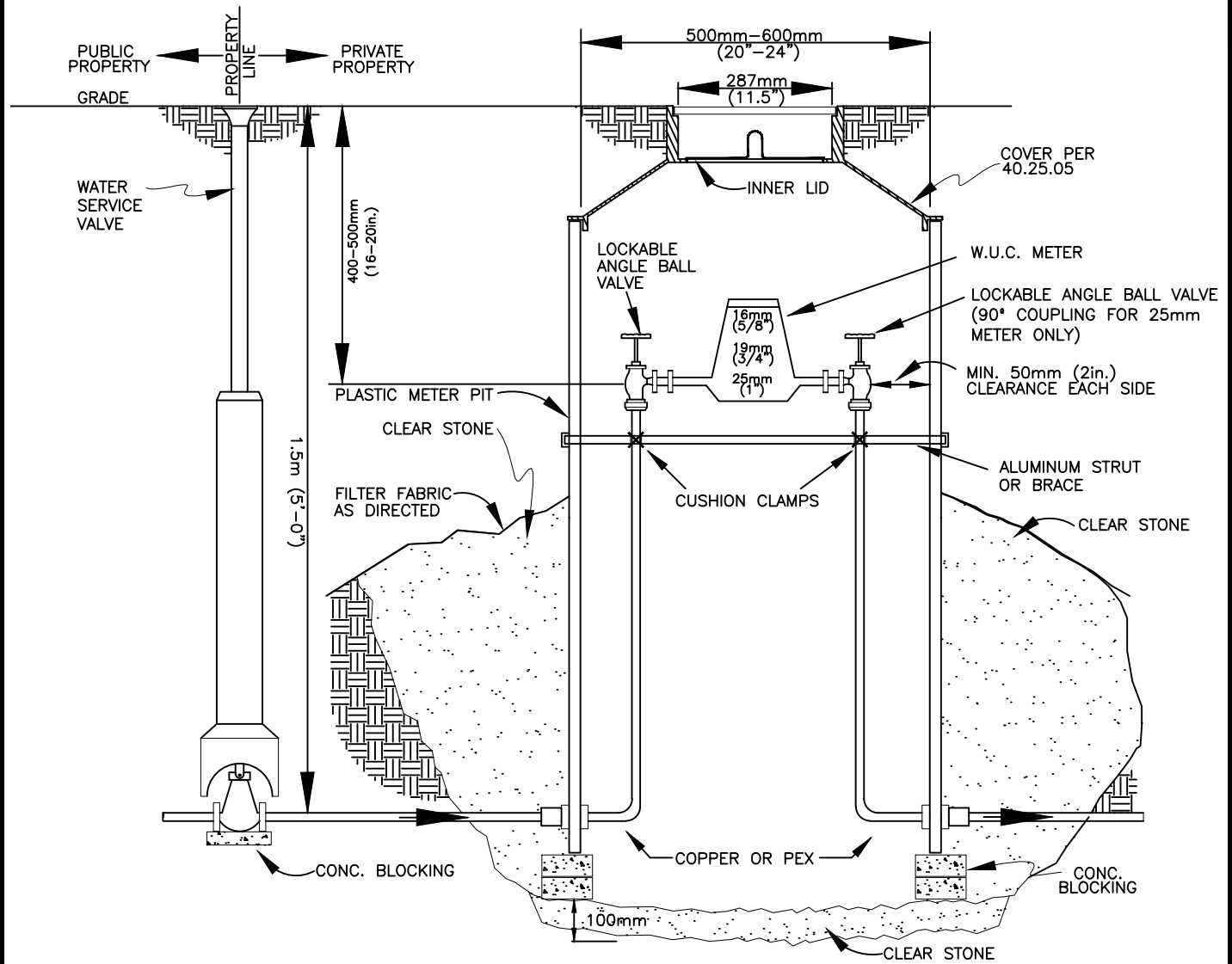

PRE-ASSEMBLED PIT

NOTE:

1. OWNER IS RESPONSIBLE TO KEEP THE METER AND METER PIT IN GOOD WORKING CONDITIONS AT ALL TIMES AND CLEAR FROM DEBRIS.
2. NO BYPASSES ALLOWED.
3. NO HAND MADE SETTERS ALLOWED.



PLASTIC METER PIT FOR 16mm, 19mm AND 25mm METERS IN GRASS AREA

DRAWN BY: B.J.O.	CHECKED BY: S.J.	APPROVED BY: C.M.	REVISION DATE: NOV. 2024	DWG. NO.: 50.08.02A
---------------------	---------------------	----------------------	-----------------------------	------------------------

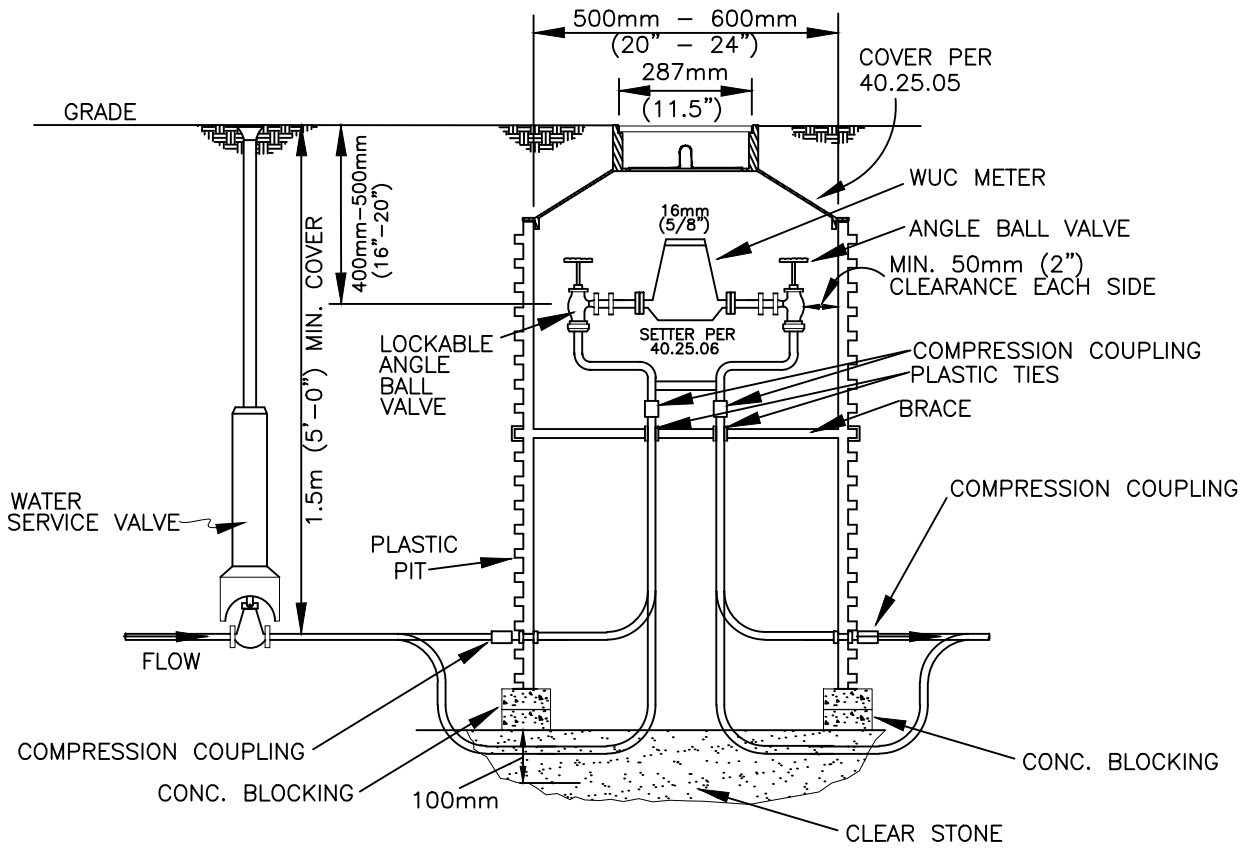

SIDE VIEW

NOTE:

1. OWNER WILL BE RESPONSIBLE TO KEEP THE METERS AND METER PIT IN GOOD WORKING CONDITIONS AT ALL TIMES AND CLEAR FROM DEBRIS.
2. NO BYPASSES ALLOWED.
3. NO HAND MADE SETTERS.

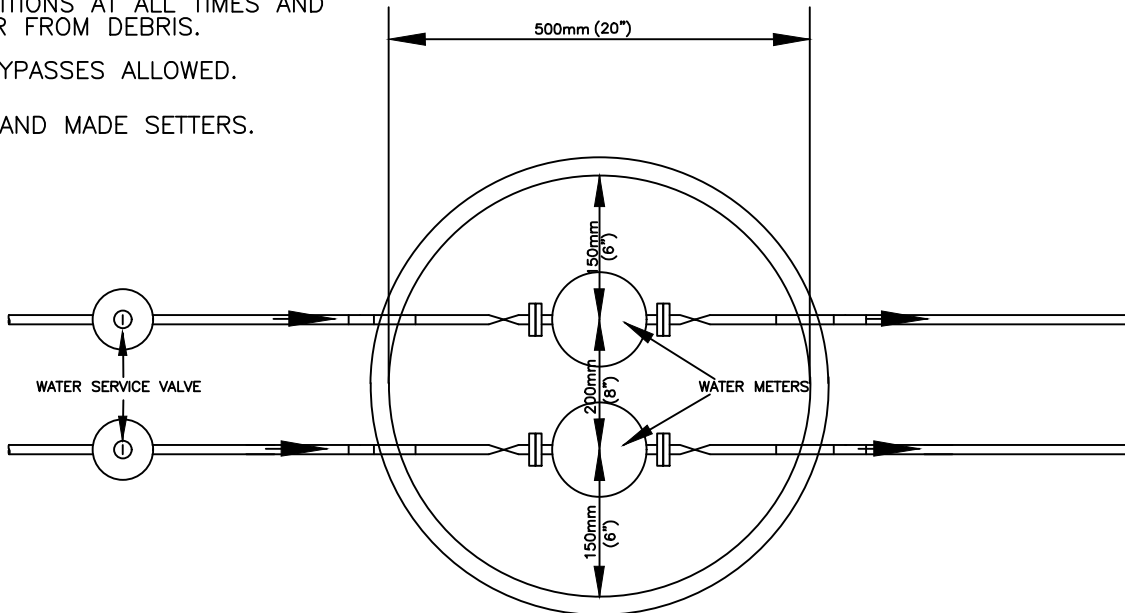

TOP VIEW



PLASTIC METER PIT AND SETTERS FOR DUAL 16mm METERS ONLY IN GRASS AREAS

DRAWN BY:
B.J.O.

CHECKED BY:
S.J.

APPROVED BY:
C.M.

REVISION DATE:
NOV. 2023

DWG. NO.:
50.08.02B

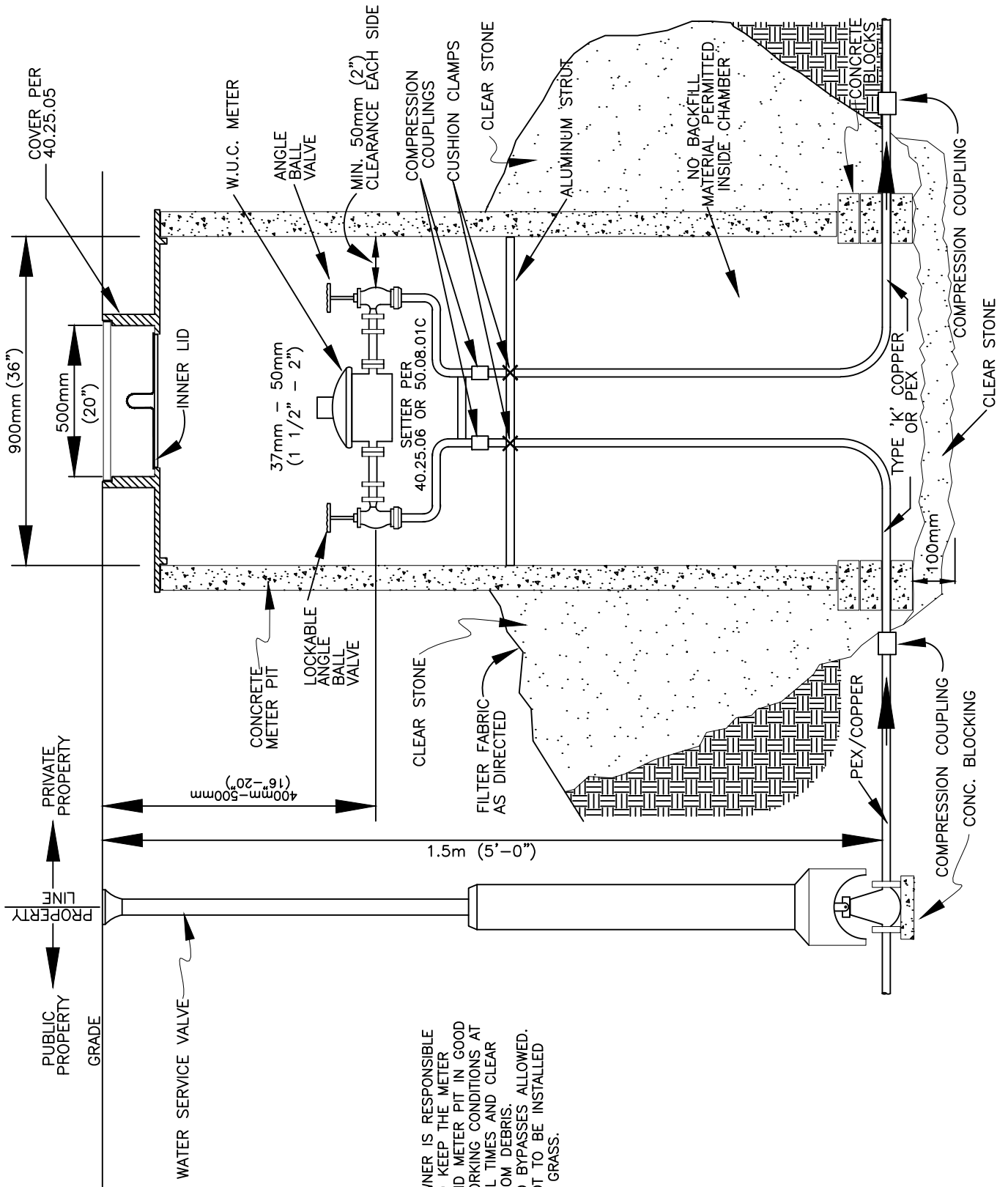

- NOTE:**
1. OWNER IS RESPONSIBLE TO KEEP THE METER AND METER PIT IN GOOD WORKING CONDITIONS AT ALL TIMES AND CLEAR FROM DEBRIS.
 2. NO BYPASSES ALLOWED.
 3. NOT TO BE INSTALLED IN GRASS.



CONCRETE METER PIT AND SETTERS FOR FLANGED METER SETTINGS - 38mm AND 50mm

DRAWN BY:
B.J.O.

CHECKED BY:
S.J.

APPROVED BY:
C.M.

REVISION DATE:
NOV. 2024

DWG. NO.:
50.08.03

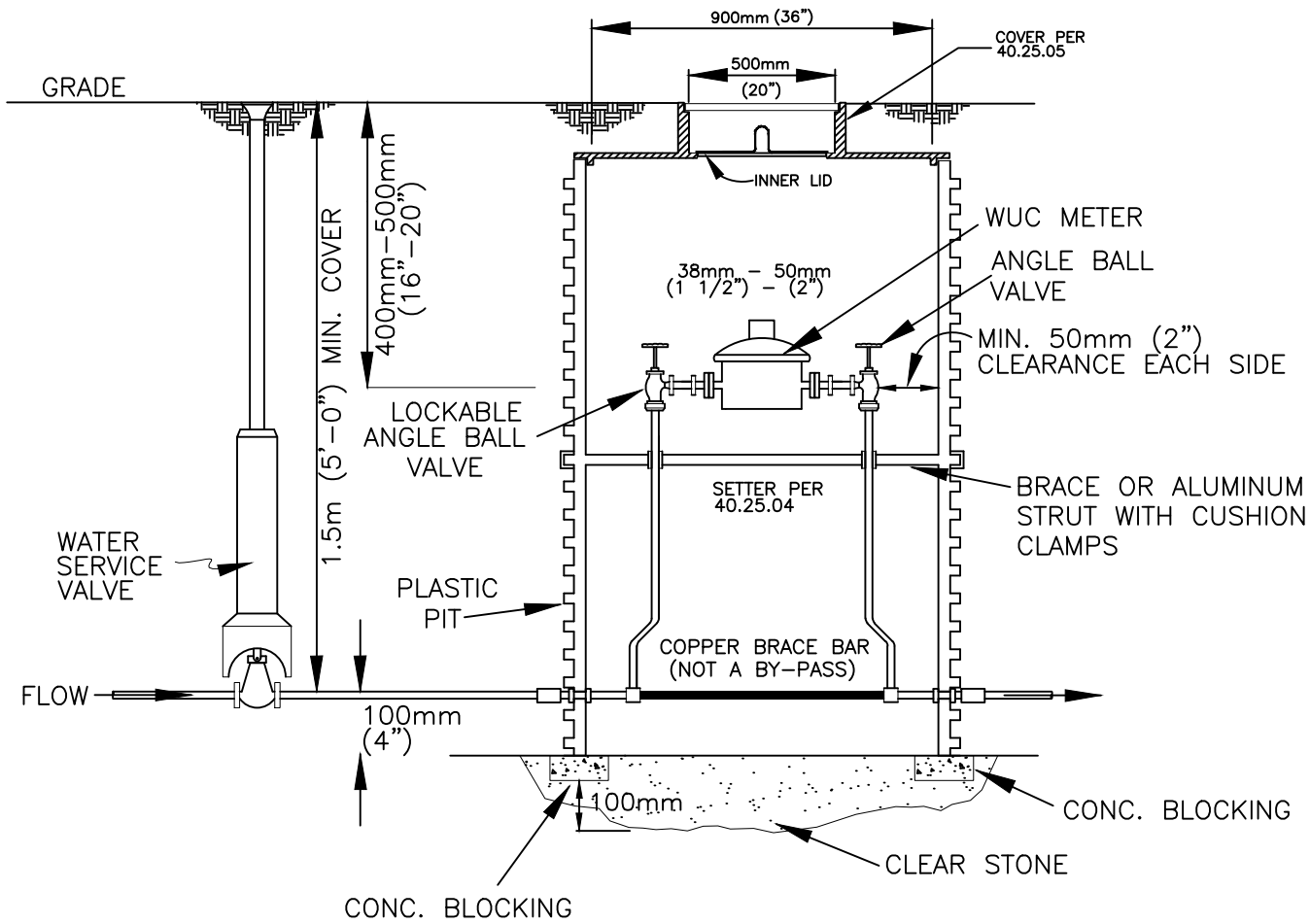

PRE-ASSEMBLED PIT

NOTE:

1. OWNER WILL BE RESPONSIBLE TO KEEP THE METER AND METER PIT IN GOOD WORKING CONDITIONS AT ALL TIMES AND CLEAR FROM DEBRIS.
2. NO BYPASSES ALLOWED.
3. NO HAND MADE SETTERS ALLOWED.



**PLASTIC METER PIT AND SETTERS FOR
38mm AND 50mm IN GRASS AREAS**

DRAWN BY: B.J.O.	CHECKED BY: S.J.	APPROVED BY: C.M.	REVISION DATE: NOV. 2024	DWG. NO.: 50.08.04
---------------------	---------------------	----------------------	-----------------------------	-----------------------

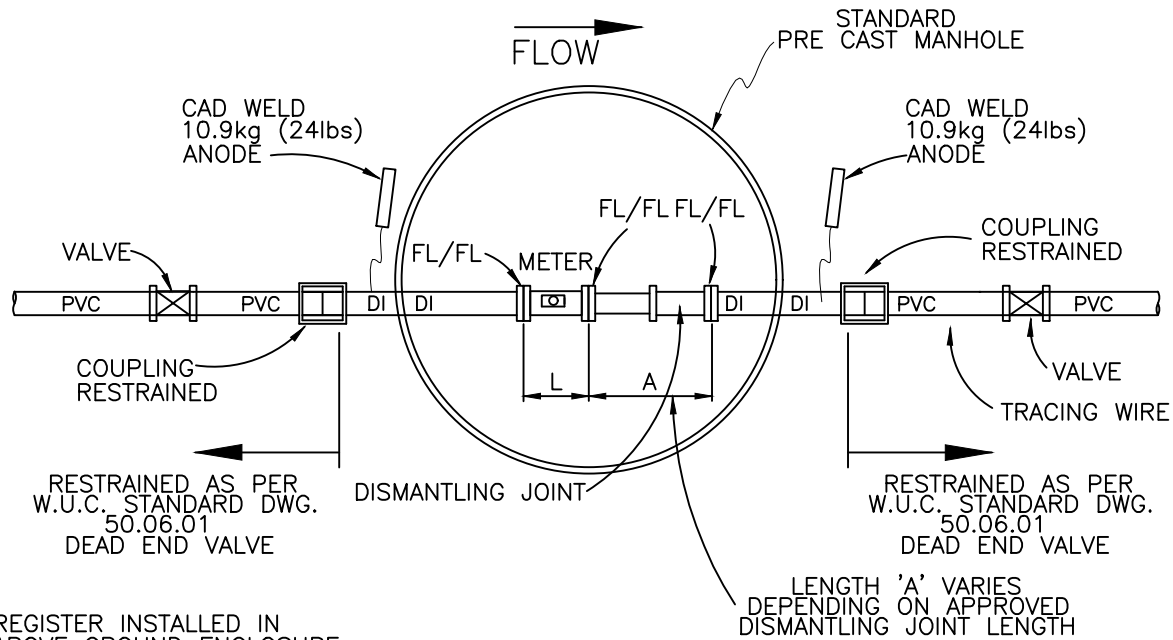

REGISTER INSTALLED IN ABOVE GROUND ENCLOSURE LOCATED ON A SOFT SURFACE AREA WITHIN 10 METERS OF SENSOR OR ANTENNA INSTALLED INSIDE MANHOLE

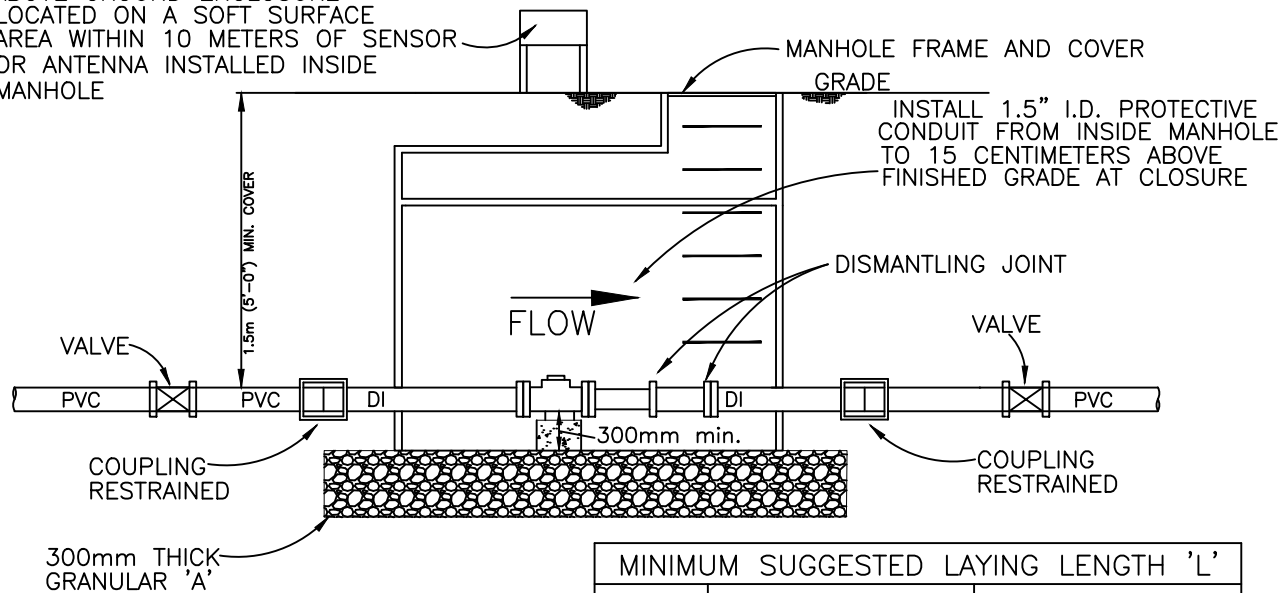

MINIMUM SUGGESTED LAYING LENGTH 'L'		
METER SIZE (mm)	METER DIMENSIONS	STANDARD PRECAST MANHOLE SIZE (m)
75	CONTACT W.U.C.	1.2
100	CONTACT W.U.C.	1.2
150	CONTACT W.U.C.	1.2
200	CONTACT W.U.C.	1.2
250	CONTACT W.U.C.	1.8



75mm AND ABOVE METER INSTALLATION IN MANHOLE

DRAWN BY:
B.J.O.

CHECKED BY:
S.J.

APPROVED BY:
C.M.

REVISION DATE:
NOV. 2024

DWG. NO.:
50.08.05

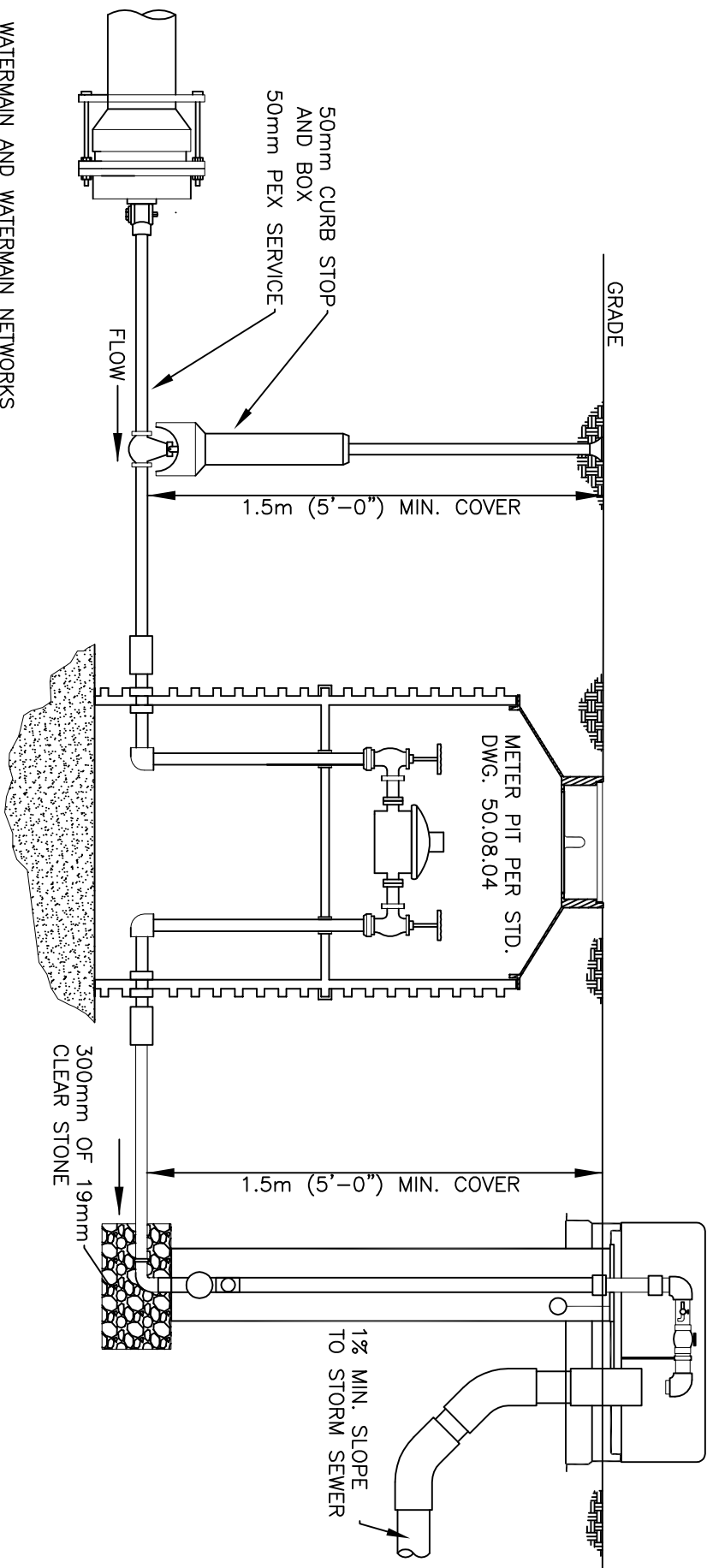

KUPFERLE ECLIPSE #9800 AUTOMATIC FLUSHING DEVICE

WATERMAIN AND WATERMAIN NETWORKS SHALL BE DESIGNED SO THAT WATER SHALL NOT REMAIN UNUSED IN THE WATERMAIN FOR MORE THAN 3 DAYS UNDER AVERAGE DAY DEMAND. WUC HAS A PRIMARY RESPONSIBILITY TO ENSURE THAT THE MINIMUM CHLORINE RESIDUALS ARE MAINTAINED IN THE DISTRIBUTION SYSTEM AND THEREFORE RESERVES THE RIGHT TO REQUIRE AUTOMATIC FLUSHING TO FACILITATE THE MAINTENANCE OF THE CHLORINE RESIDUAL IF NO OTHER OPTIONS ARE AVAILABLE.

WATER METER PITS ARE TO BE IN ACCORDANCE WITH STANDARD DRAWING 50.08.04 OF THE WINDSOR UTILITIES COMMISSION DESIGN GUIDELINES AND SPECIFICATIONS FOR WATERMAIN AND WATER SERVICE INSTALLATION AND MANUFACTURERS RECOMMENDATIONS.

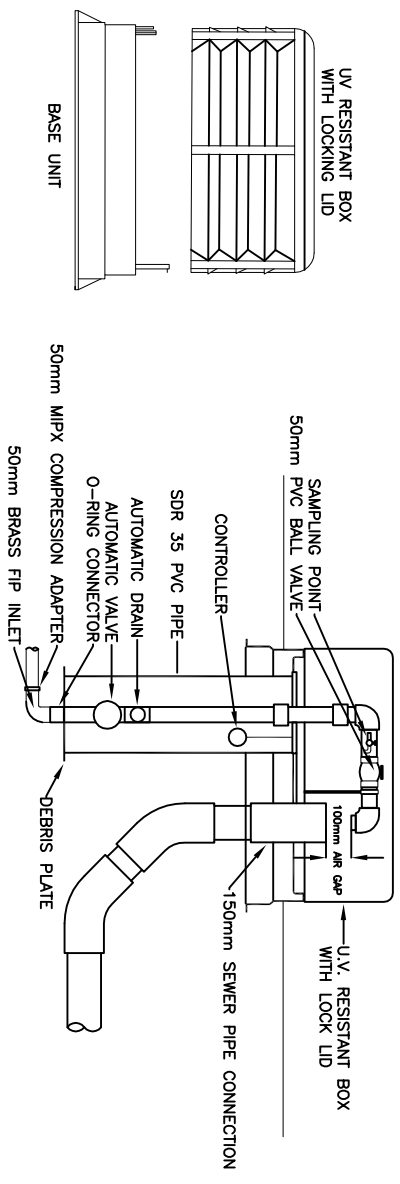

METERED AUTOMATIC FLUSHING DEVICE

DRAWN BY:	CHECKED BY: B.J.O.	APPROVED BY: N.P.	REVISION DATE: MARCH/2015	DWG. NO.: 50.08.06
-----------	-----------------------	----------------------	------------------------------	-----------------------

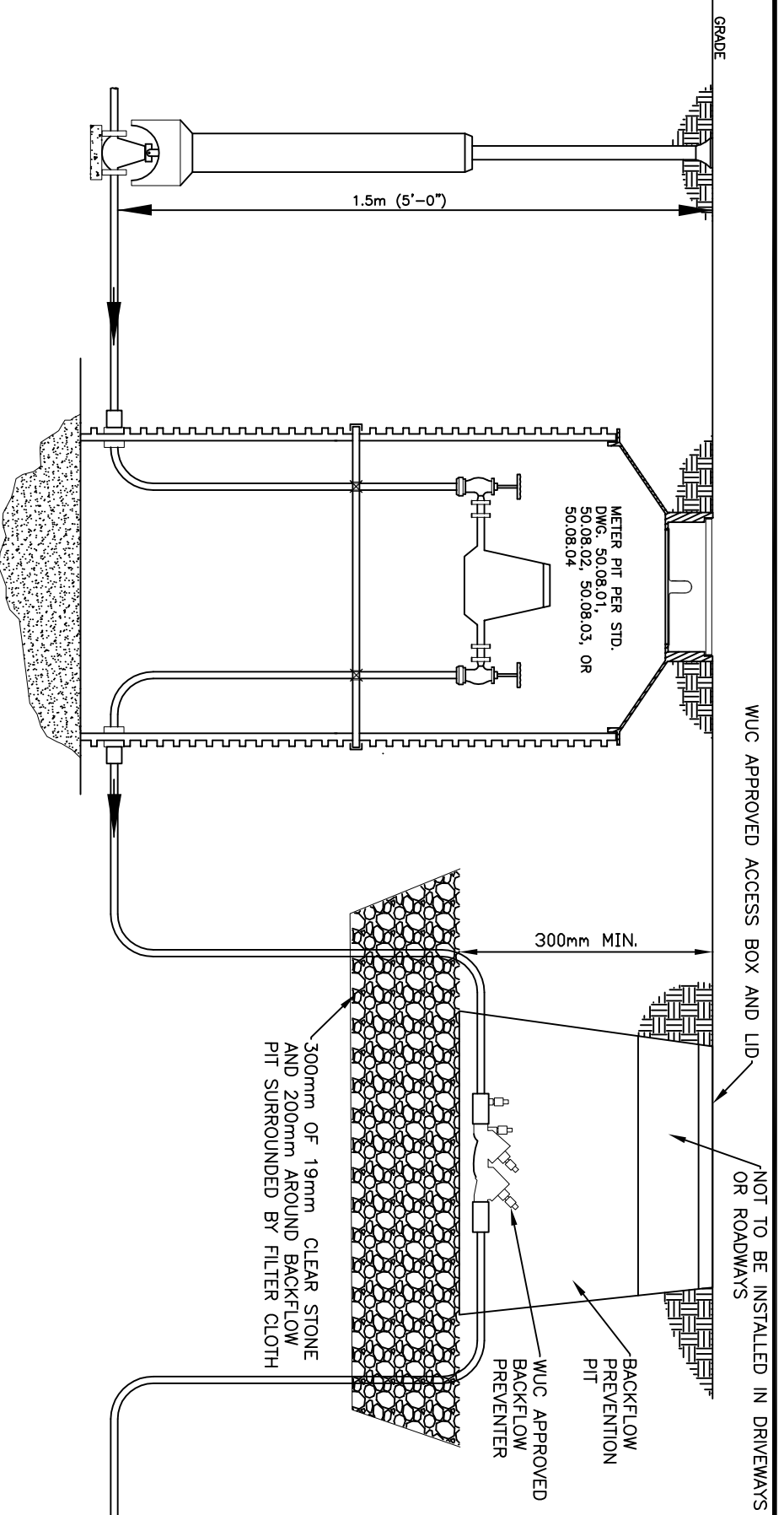

METERED IRRIGATION SYSTEM AND BACKFLOW PREVENTION ASSEMBLY
 FOR THE PROTECTION OF THE WATER DISTRIBUTION SYSTEM, ALL IRRIGATION SYSTEMS MUST BE METERED AND MUST HAVE A WUC APPROVED BACKFLOW PREVENTION DEVICE.

BACKFLOW PREVENTION DEVICES SHALL BE INSTALLED IN ACCORDANCE WITH THE ONTARIO BUILDING CODE AND CAN/CSA-B64 SELECTION AND INSTALLATION OF THE BACKFLOW PREVENTERS / MAINTENANCE AND FIELD TESTING OF BACKFLOW PREVENTERS AND WUC BYLAW 90.

ALL BACKFLOW PREVENTION DEVICES SHALL BE INSPECTED AND TESTED AT THE EXPENSE OF THE OWNER, UPON INSTALLATION, AND THEREAFTER ANNUALLY BY PERSONNEL APPROVED BY WUC.

WATER METER PITS ARE TO BE PER WUC SPECIFICATION DRAWING 50.08.03 OR 50.08.04 FOR 37mm AND 50mm SERVICES AND 50.08.01 AND 50.08.02 FOR 19mm AND 25mm SERVICES.



BACKFLOW PREVENTER FOR SUMMER SERVICE

DRAWN BY:	CHECKED BY: B.J.O.	APPROVED BY: N.P.	REVISION DATE: MARCH/2015	DWG. NO.: 50.08.07
-----------	-----------------------	----------------------	------------------------------	-----------------------

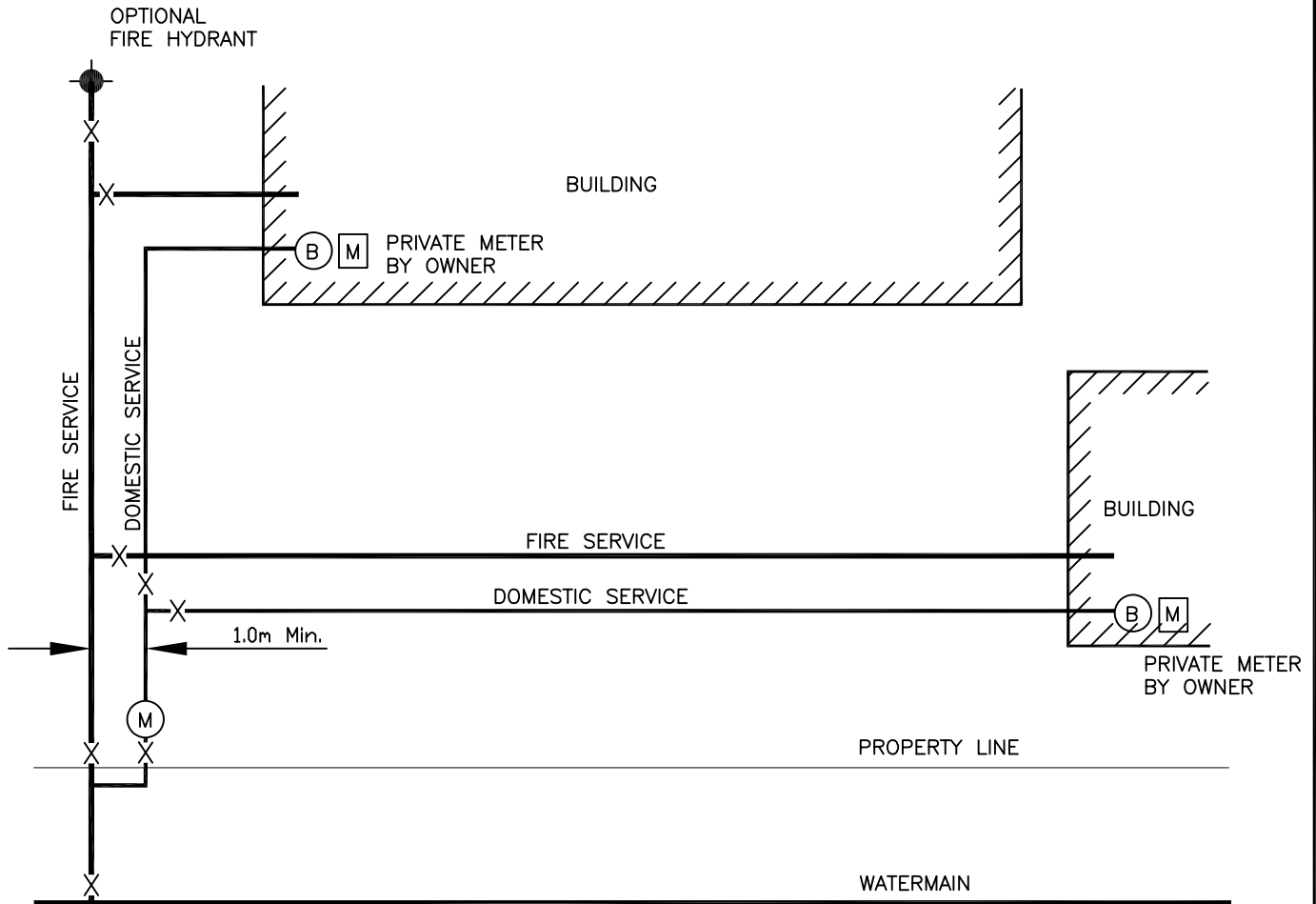

LEGEND

- (B) BACKFLOW PREVENTER
- (M) METER IN CHAMBER
- [M] PRIVATE METER BY OWNER
- X VALVE & BOX

NOTE 1:
PREMISE BACKFLOW PREVENTERS ON NEW INSTALLATIONS SHALL BE RP TYPE AND BE INSTALLED AS THE SERVICE ENTERS THE BUILDING BEFORE ANY CONNECTIONS OCCUR.

NOTE 2: METERING OPTIONS TO BE DECIDED BY WATER ENGINEERING ON A CASE BY CASE BASIS.

OPTION 'A'

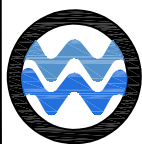

**WINDSOR
UTILITIES
COMMISSION**

WATER SERVICING FOR MULTIPLE BUILDINGS ON ONE LOT FOR COMMERCIAL, INSTITUTIONAL, AND APARTMENT BUILDINGS

DRAWN BY:
B.J.O.

CHECKED BY:
S.J.

APPROVED BY:
C.M.

REVISION DATE:
NOV. 2023

DWG. NO.:
50.09.01A

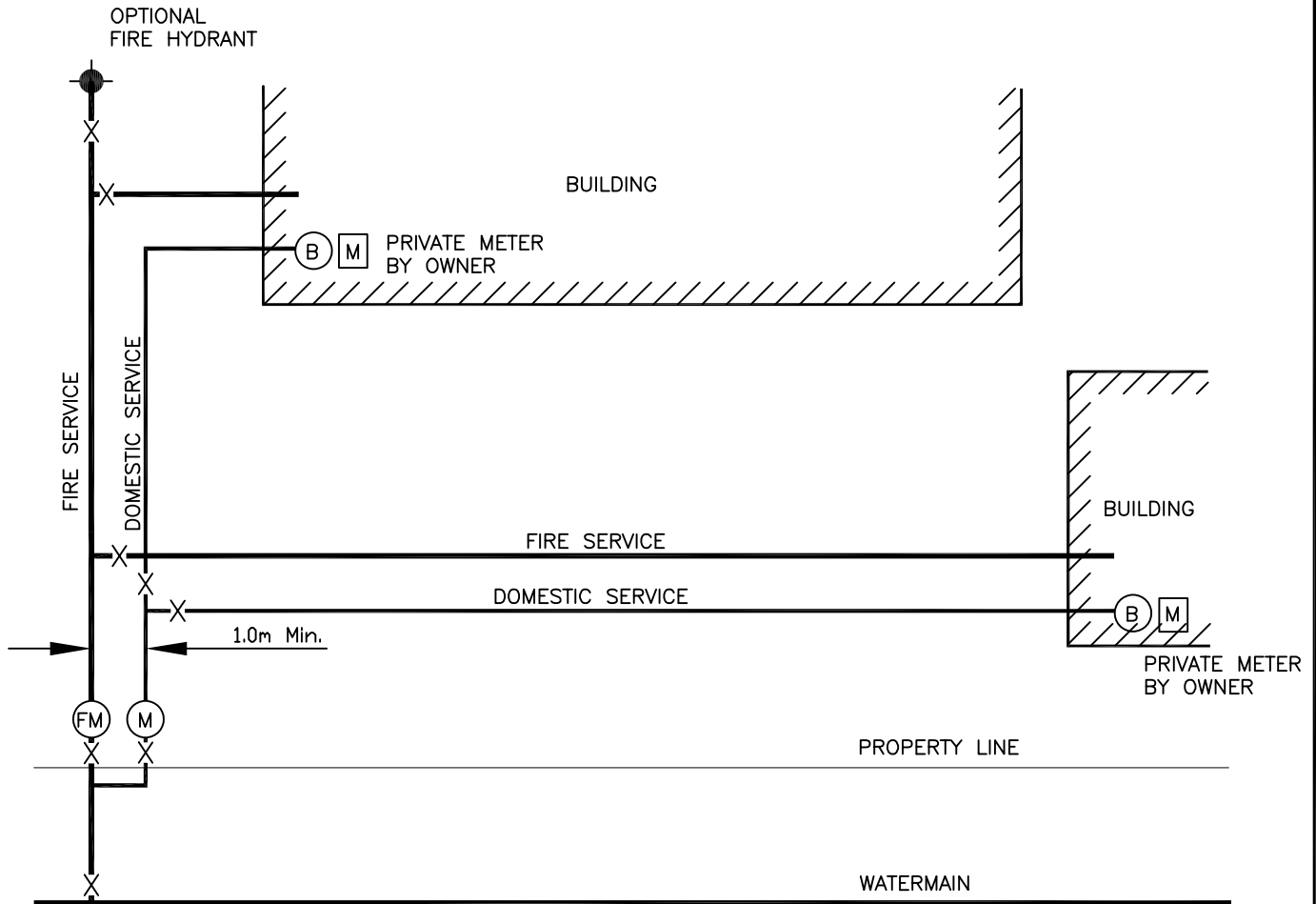

LEGEND

- (B) BACKFLOW PREVENTER
- (M) METER IN CHAMBER
- (FM) FIRE METER IN CHAMBER
- [M] PRIVATE METER BY OWNER
- X VALVE & BOX

NOTE 1:

PREMISE BACKFLOW PREVENTERS ON NEW INSTALLATIONS SHALL BE RP TYPE AND BE INSTALLED AS THE SERVICE ENTERS THE BUILDING BEFORE ANY CONNECTIONS OCCUR.

NOTE 2: METERING OPTIONS TO BE DECIDED BY WATER ENGINEERING ON A CASE BY CASE BASIS.

OPTION 'B'

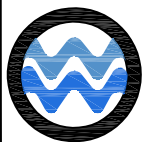

**WINDSOR
UTILITIES
COMMISSION**

WATER SERVICING FOR MULTIPLE BUILDINGS ON ONE LOT FOR INDUSTRIAL PROPERTIES

DRAWN BY:
B.J.O.

CHECKED BY:
S.J.

APPROVED BY:
C.M.

REVISION DATE:
NOV. 2023

DWG. NO.:
50.09.01B

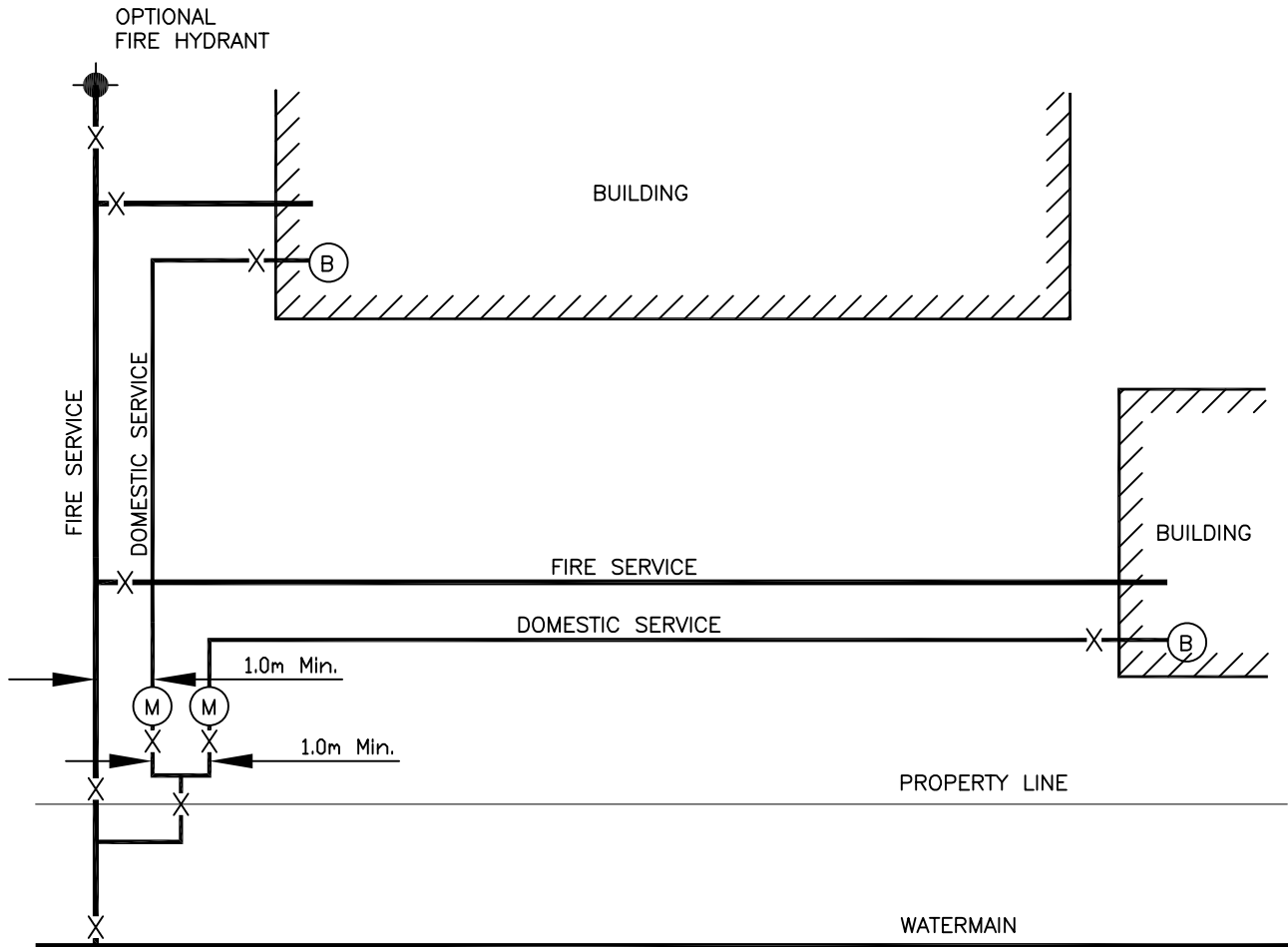

LEGEND

- ⓑ BACKFLOW PREVENTER
- Ⓜ METER IN CHAMBER
- ✕ VALVE & BOX

NOTE 1:
PREMISE BACKFLOW PREVENTERS ON NEW INSTALLATIONS SHALL BE RP TYPE AND BE INSTALLED AS THE SERVICE ENTERS THE BUILDING BEFORE ANY CONNECTIONS OCCUR.

NOTE 2: METERING OPTIONS TO BE DECIDED BY WATER ENGINEERING ON A CASE BY CASE BASIS.

OPTION 'C'



WATER SERVICING FOR MULTIPLE BUILDINGS ON ONE LOT FOR COMMERCIAL, INSTITUTIONAL, AND APARTMENT BUILDINGS

DRAWN BY: B.J.O.	CHECKED BY: S.J.	APPROVED BY: C.M.	REVISION DATE: NOV. 2023	DWG. NO.: 50.09.01C
---------------------	---------------------	----------------------	-----------------------------	------------------------

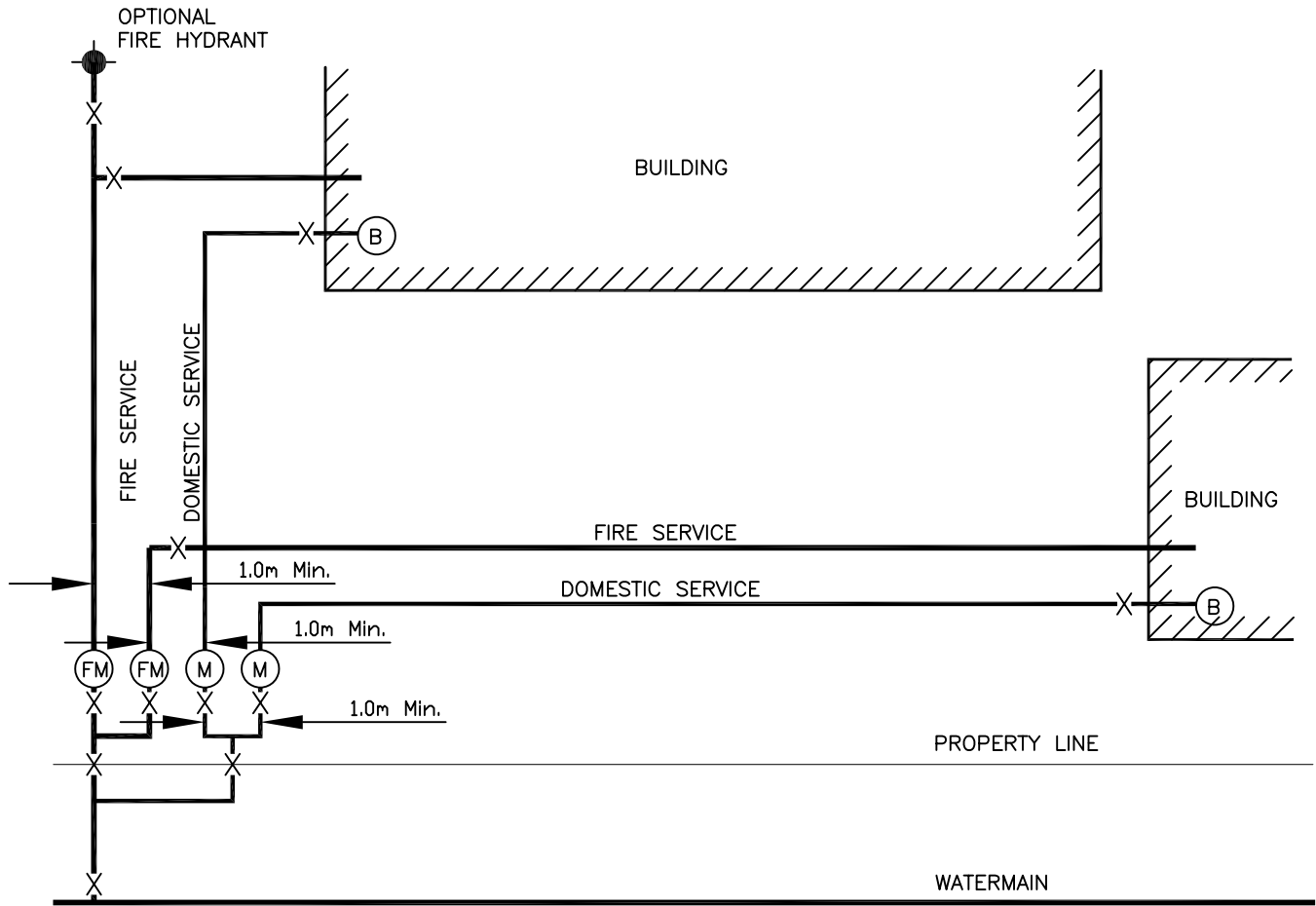

LEGEND

- (B) BACKFLOW PREVENTER
- (M) METER IN CHAMBER
- (FM) FIRE METER IN CHAMBER
- X VALVE & BOX

NOTE 1:
PREMISE BACKFLOW PREVENTERS ON NEW INSTALLATIONS SHALL BE RP TYPE AND BE INSTALLED AS THE SERVICE ENTERS THE BUILDING BEFORE ANY CONNECTIONS OCCUR.

NOTE 2: METERING OPTIONS TO BE DECIDED BY WATER ENGINEERING ON A CASE BY CASE BASIS.

OPTION 'D'



WATER SERVICING FOR MULTIPLE BUILDINGS ON ONE LOT INDUSTRIAL PROPERTIES

DRAWN BY: B.J.O.	CHECKED BY: S.J.	APPROVED BY: C.M.	REVISION DATE: NOV. 2023	DWG. NO.: 50.09.01D
---------------------	---------------------	----------------------	-----------------------------	------------------------

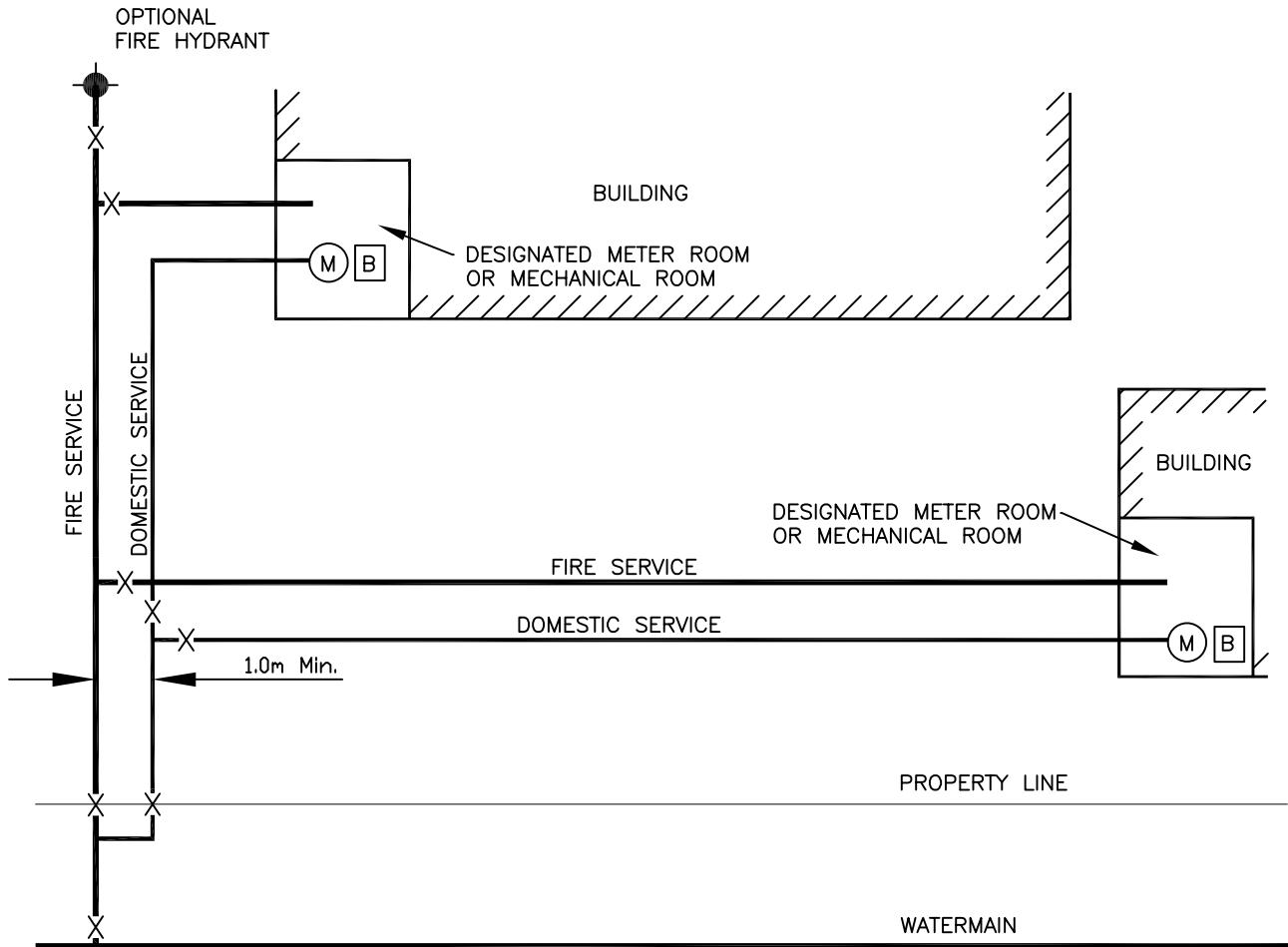

LEGEND

Ⓜ METER IN DESIGNATED METER ROOM OR MECHANICAL ROOM

ⓑ BACKFLOW PREVENTER

✕ VALVE & BOX

NOTE 1:

PREMISE BACKFLOW PREVENTERS ON NEW INSTALLATIONS SHALL BE RP TYPE AND BE INSTALLED AS THE SERVICE ENTERS THE BUILDING AFTER THE METER BUT BEFORE ANY CONNECTIONS OCCUR.

NOTE 2: FOR METERS TO BE INSTALLED INDOORS THERE NEEDS TO BE A DESIGNATED METER ROOM OR MECHANICAL ROOM WITH EXTERIOR ACCESS ONLY (EXCEPT FOR APARTMENT BUILDINGS) AND 24/7 ACCESS FOR W.U.C.

NOTE 3: METERING OPTIONS TO BE DECIDED BY WATER ENGINEERING ON A CASE BY CASE BASIS.

OPTION 'E'

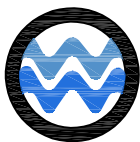

**WINDSOR
UTILITIES
COMMISSION**

WATER SERVICING FOR MULTIPLE BUILDINGS ON ONE LOT FOR COMMERCIAL, INSTITUTIONAL, AND APARTMENT BUILDINGS

DRAWN BY:
B.J.O.

CHECKED BY:
S.J.

APPROVED BY:
C.M.

REVISION DATE:
NOV. 2023

DWG. NO.:
50.09.01E

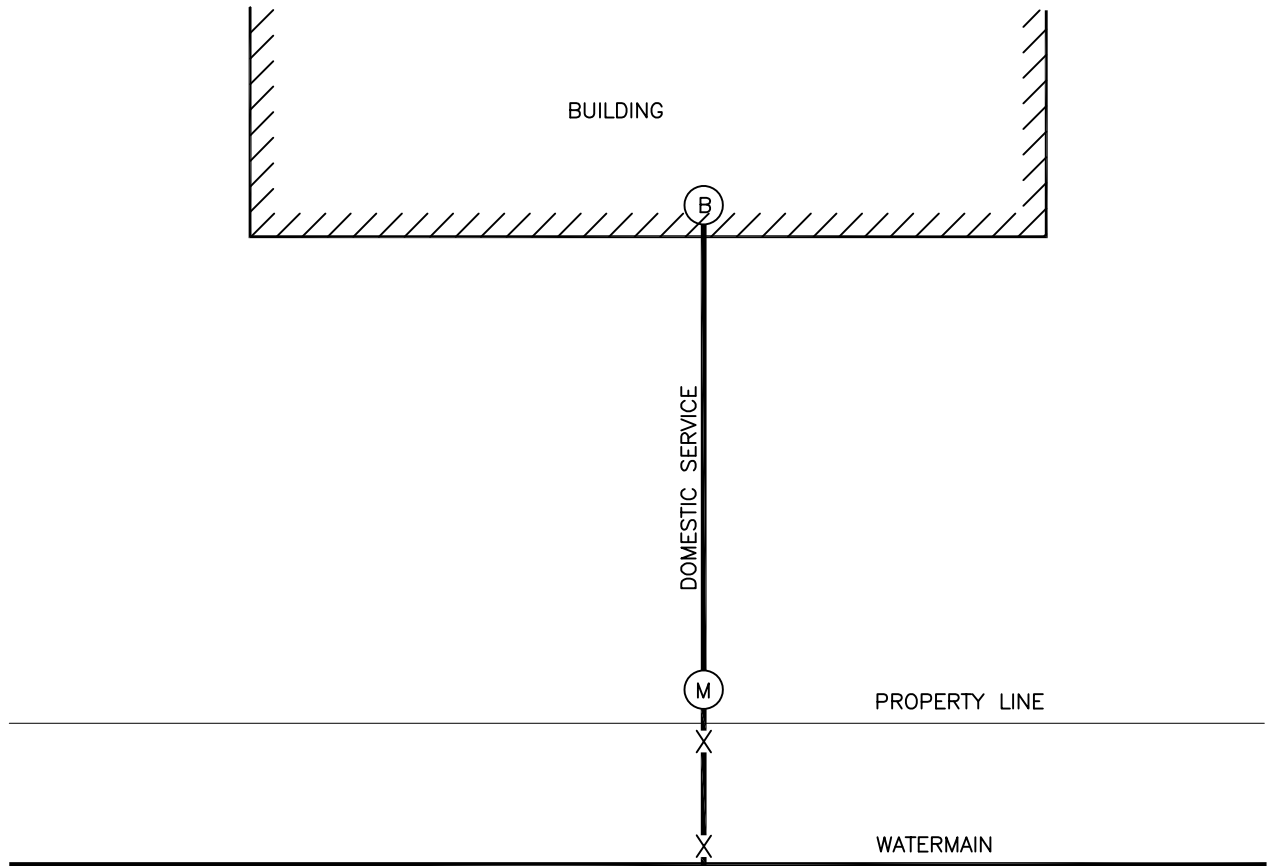

LEGEND

- (B) BACKFLOW PREVENTER
- (M) METER IN CHAMBER
- X VALVE & BOX

NOTE 1: PREMISE BACKFLOW PREVENTERS ON NEW INSTALLATIONS SHALL BE RP TYPE AND BE INSTALLED AS THE SERVICE ENTERS THE BUILDING BEFORE ANY CONNECTIONS OCCUR.

NOTE 2: METERING OPTIONS TO BE DECIDED BY WATER ENGINEERING ON A CASE BY CASE BASIS.

OPTION 'A'

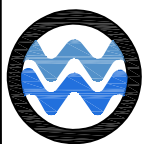

**WINDSOR
UTILITIES
COMMISSION**

**DOMESTIC WATER SERVICE FOR INDUSTRIAL,
COMMERCIAL, INSTITUTIONAL**

DRAWN BY:
B.J.O.

CHECKED BY:
S.J.

APPROVED BY:
C.M.

REVISION DATE:
NOV. 2023

DWG. NO.:
50.09.02A

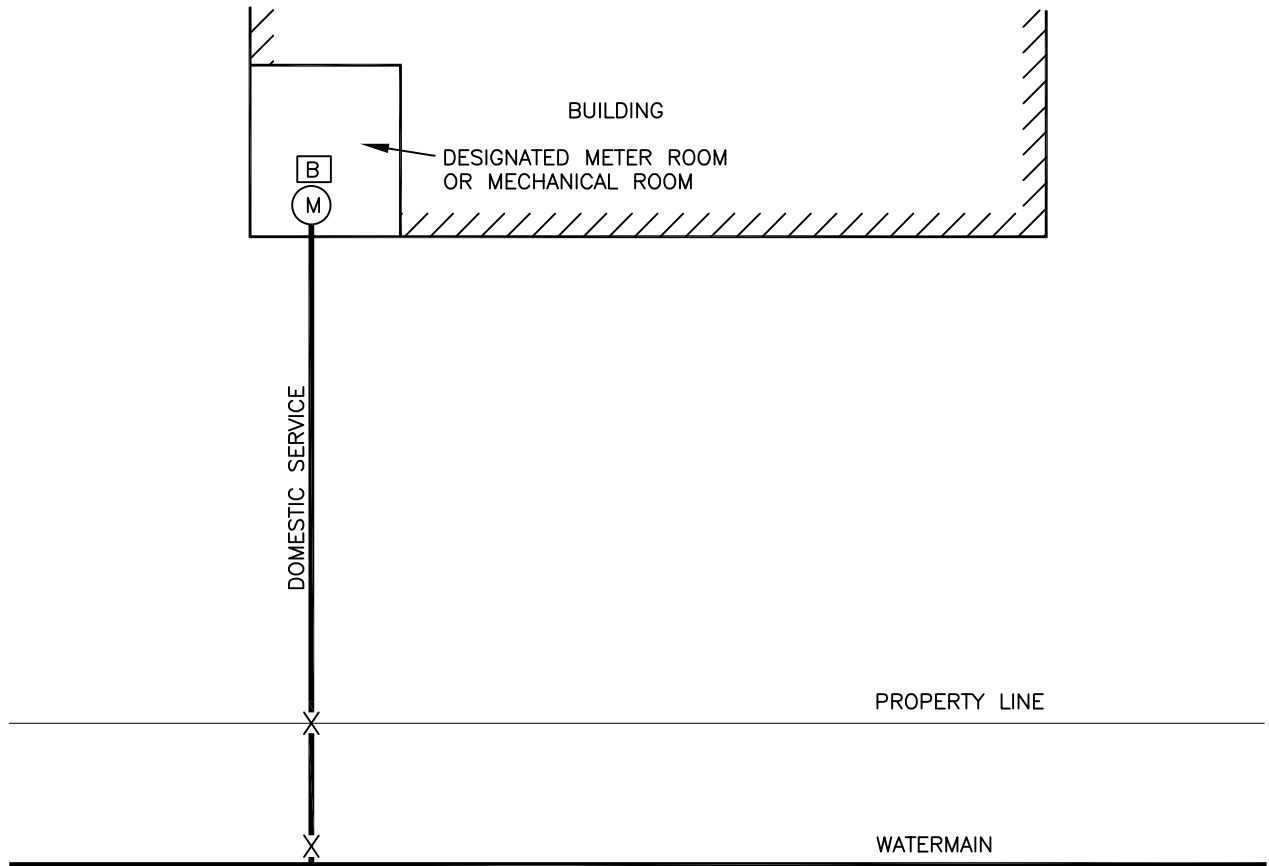

LEGEND

- Ⓟ BACKFLOW PREVENTER
- Ⓜ METER IN DESIGNATED METER ROOM OR MECHANICAL ROOM
- ✕ VALVE & BOX

NOTE 1:
PREMISE BACKFLOW PREVENTERS ON NEW INSTALLATIONS SHALL BE RP TYPE AND BE INSTALLED AS THE SERVICE ENTERS THE BUILDING AFTER THE METER BUT BEFORE ANY CONNECTIONS OCCUR.

NOTE 2: FOR METERS TO BE INSTALLED INDOORS THERE NEEDS TO BE A DESIGNATED METER ROOM OR MECHANICAL ROOM WITH EXTERIOR ACCESS ONLY (EXCEPT FOR APARTMENT BUILDINGS) AND 24/7 ACCESS FOR W.U.C.

NOTE 3: METERING OPTIONS TO BE DECIDED BY WATER ENGINEERING ON A CASE BY CASE BASIS.

OPTION 'B'



**WINDSOR
UTILITIES
COMMISSION**

**DOMESTIC WATER SERVICE FOR COMMERCIAL,
INSTITUTIONAL, AND APARTMENT BUILDINGS**

DRAWN BY: B.J.O.	CHECKED BY: S.J.	APPROVED BY: C.M.	REVISION DATE: NOV. 2023	DWG. NO.: 50.09.02B
---------------------	---------------------	----------------------	-----------------------------	-------------------------------

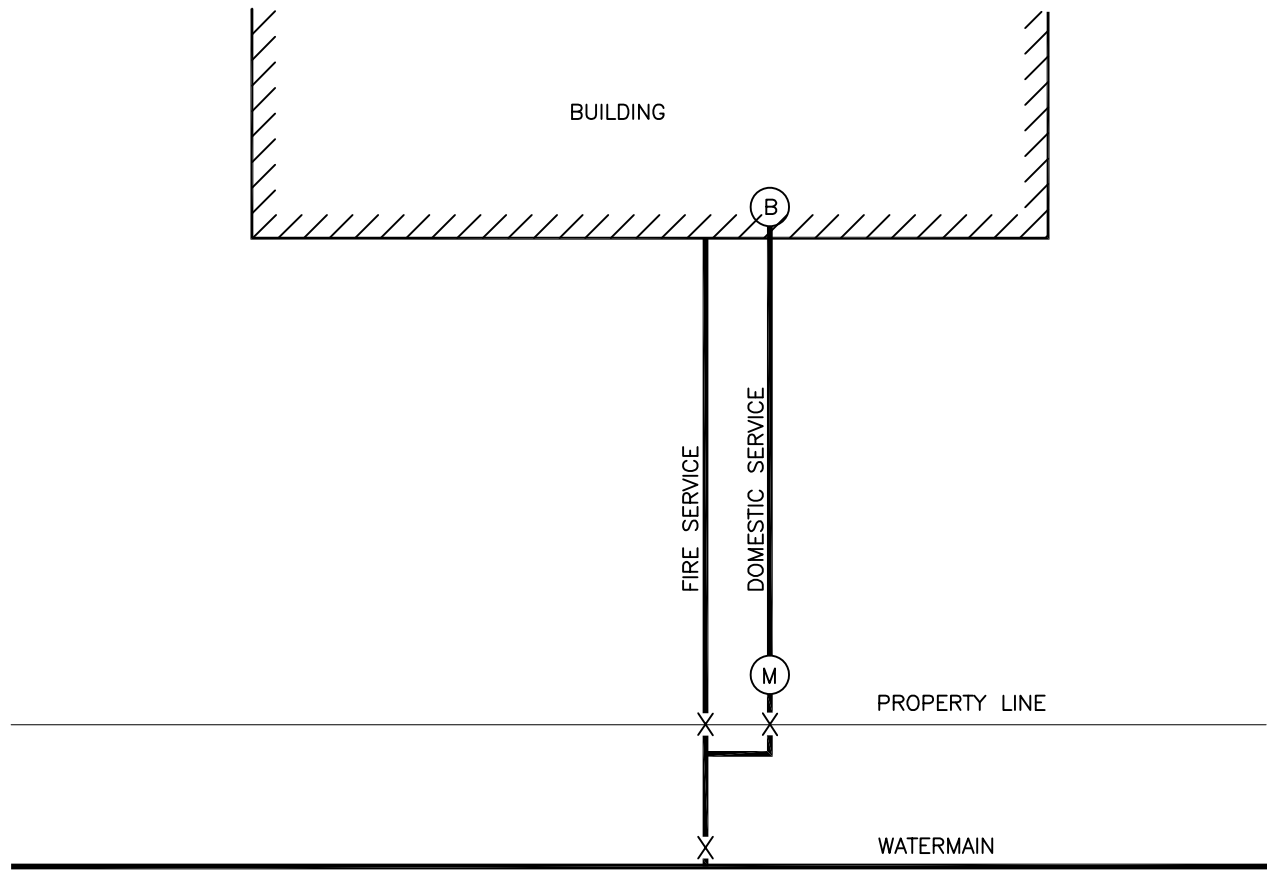

LEGEND

ⓑ BACKFLOW PREVENTER

Ⓜ METER IN CHAMBER

✕ VALVE & BOX

NOTE 1: PREMISE BACKFLOW PREVENTERS ON NEW INSTALLATIONS SHALL BE RP TYPE AND BE INSTALLED AS THE SERVICE ENTERS THE BUILDING BEFORE ANY CONNECTIONS OCCUR.

NOTE 2: METERING OPTIONS TO BE DECIDED BY WATER ENGINEERING ON A CASE BY CASE BASIS.

OPTION 'A'

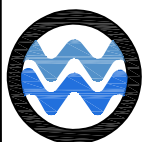

**WINDSOR
UTILITIES
COMMISSION**

**FIRE AND DOMESTIC WATER SERVICING FOR COMMERCIAL,
INSTITUTIONAL, AND APARTMENT BUILDINGS**

DRAWN BY:
B.J.O.

CHECKED BY:
S.J.

APPROVED BY:
C.M.

REVISION DATE:
NOV. 2023

DWG. NO.:
50.09.03A

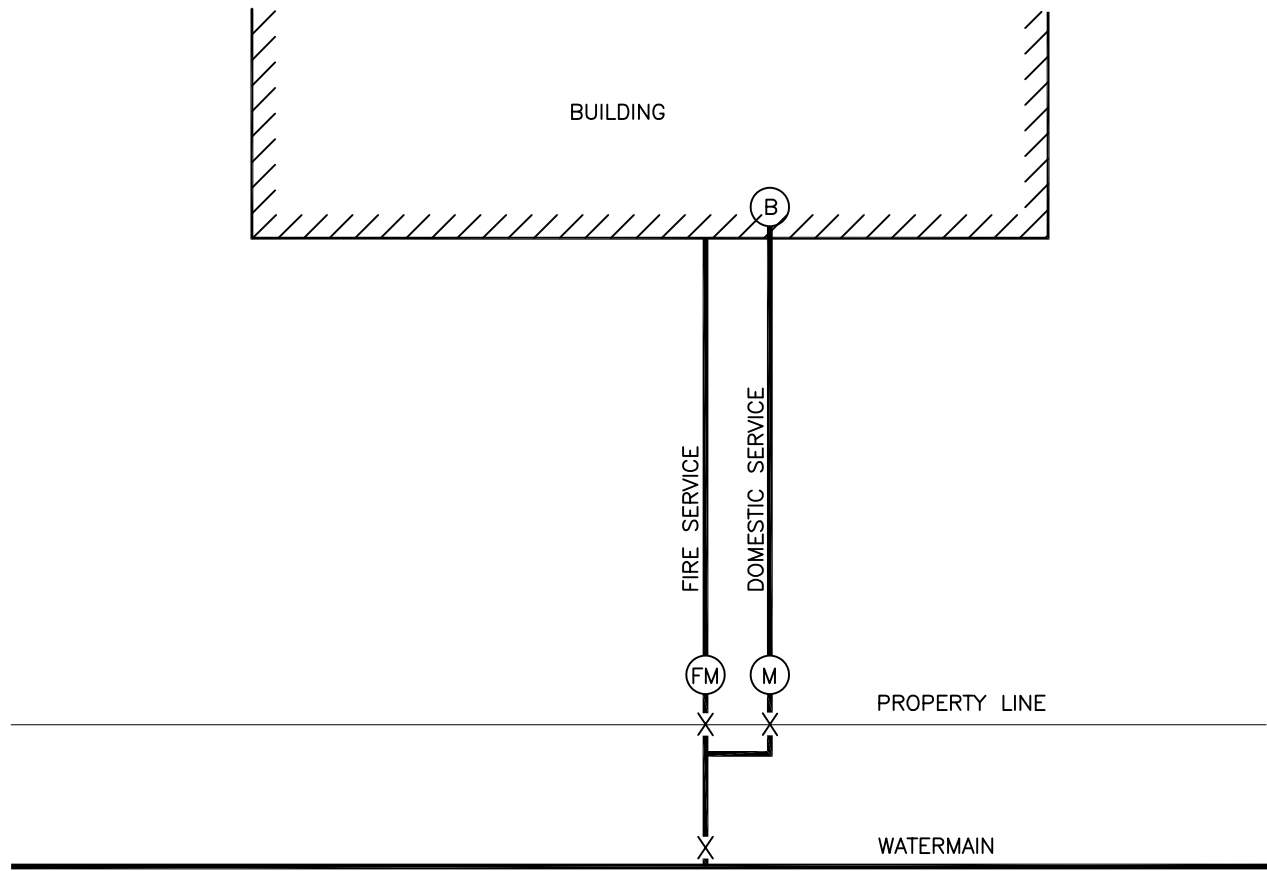

LEGEND

- (B) BACKFLOW PREVENTER
- (M) METER IN CHAMBER
- (FM) FIRE METER IN CHAMBER
- X VALVE & BOX

NOTE 1: PREMISE BACKFLOW PREVENTERS ON NEW INSTALLATIONS SHALL BE RP TYPE AND BE INSTALLED AS THE SERVICE ENTERS THE BUILDING BEFORE ANY CONNECTIONS OCCUR.

NOTE 2: METERING OPTIONS TO BE DECIDED BY WATER ENGINEERING ON A CASE BY CASE BASIS.

OPTION 'B'



**WINDSOR
UTILITIES
COMMISSION**

**FIRE AND DOMESTIC WATER SERVICING FOR
INDUSTRIAL PROPERTIES**

DRAWN BY: B.J.O.	CHECKED BY: S.J.	APPROVED BY: C.M.	REVISION DATE: NOV. 2023	DWG. NO.: 50.09.03B
---------------------	---------------------	----------------------	-----------------------------	-------------------------------

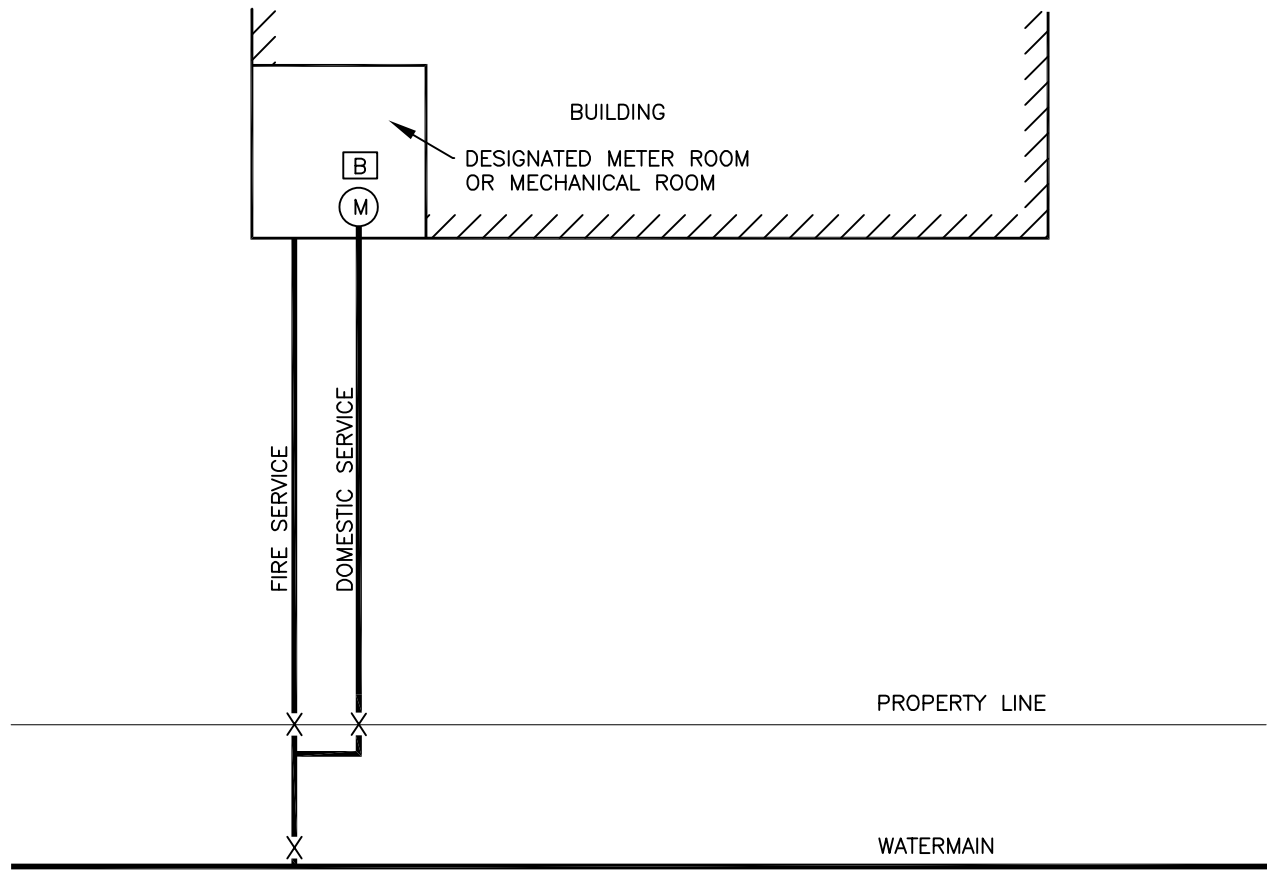

LEGEND

- BACKFLOW PREVENTER
- Ⓜ METER IN DESIGNATED METER ROOM OR MECHANICAL ROOM
- × VALVE & BOX

NOTE 1:
PREMISE BACKFLOW PREVENTERS ON NEW INSTALLATIONS SHALL BE RP TYPE AND BE INSTALLED AS THE SERVICE ENTERS THE BUILDING AFTER THE METER BUT BEFORE ANY CONNECTIONS OCCUR.

NOTE 2: FOR METERS TO BE INSTALLED INDOORS THERE NEEDS TO BE A DESIGNATED METER ROOM OR MECHANICAL ROOM WITH EXTERIOR ACCESS ONLY (EXCEPT FOR APARTMENT BUILDINGS) AND 24/7 ACCESS FOR W.U.C.

NOTE 3: METERING OPTIONS TO BE DECIDED BY WATER ENGINEERING ON A CASE BY CASE BASIS.

OPTION 'C'



FIRE AND DOMESTIC WATER SERVICING FOR COMMERCIAL, INSTITUTIONAL, AND APARTMENT BUILDINGS

DRAWN BY: B.J.O.	CHECKED BY: S.J.	APPROVED BY: C.M.	REVISION DATE: NOV. 2023	DWG. NO.: 50.09.03C
---------------------	---------------------	----------------------	-----------------------------	-------------------------------

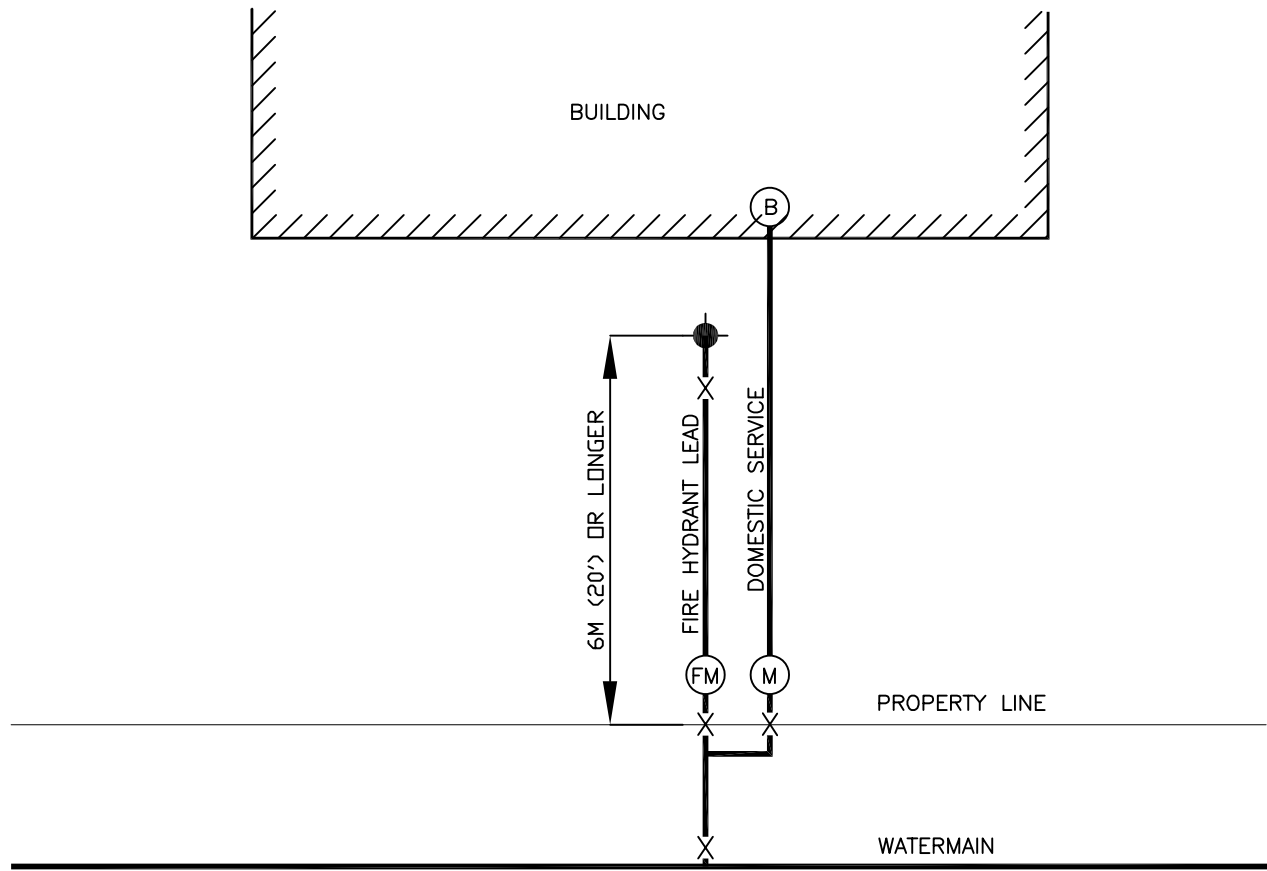

LEGEND

- (B) BACKFLOW PREVENTER
- (M) METER IN CHAMBER
- (FM) FIRE METER IN CHAMBER
- X VALVE & BOX

NOTE 1: PREMISE BACKFLOW PREVENTERS ON NEW INSTALLATIONS SHALL BE RP TYPE AND BE INSTALLED AS THE SERVICE ENTERS THE BUILDING BEFORE ANY CONNECTIONS OCCUR.

NOTE 2: METERING OPTIONS TO BE DECIDED BY WATER ENGINEERING ON A CASE BY CASE BASIS.

NOTE 3: FIRE HYDRANT LEADS 6 METERS (20') AND LONGER ARE REQUIRED TO HAVE A FIRE METER INSTALLED AND BILLED TO THE ACCOUNT HOLDER OF THE DOMESTIC SERVICE.

OPTION 'D'



**WINDSOR
UTILITIES
COMMISSION**

FIRE HYDRANT LEAD AND DOMESTIC WATER SERVICING FOR INDUSTRIAL PROPERTIES

DRAWN BY:
B.J.O.

CHECKED BY:
S.J.

APPROVED BY:
C.M.

REVISION DATE:
NOV. 2023

DWG. NO.:
50.09.03D

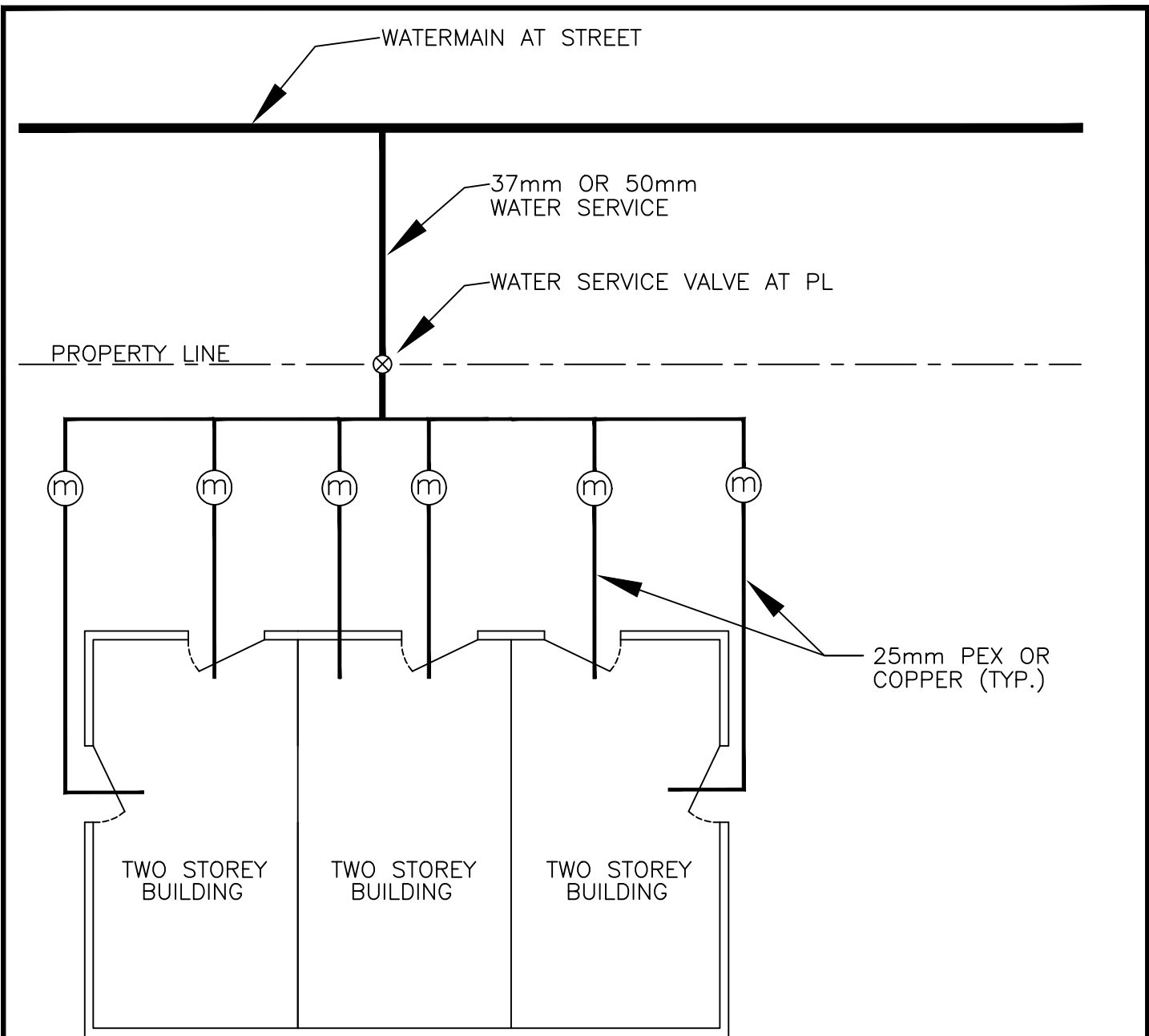

Ⓜ METER IN A PIT

NOTE 1: METERS SHALL BE IN PITS FOR ALL RESIDENTIAL AND INDUSTRIAL PROPERTIES.

NOTE 2: METERS SHALL BE INSTALLED IN PITS FOR ALL COMMERCIAL, INSTITUTIONAL, AND APARTMENT BUILDINGS WHEN NO DESIGNATED METER ROOM OR MECHANICAL ROOM IS PROPOSED.

NOTE 3: FOR METERS TO BE INSTALLED INDOORS THERE NEEDS TO BE A DESIGNATED METER ROOM OR MECHANICAL ROOM WITH EXTERIOR ACCESS ONLY AND 24/7 ACCESS FOR W.U.C.

NOTE 4: METERING OPTIONS TO BE DECIDED BY WATER ENGINEERING ON A CASE BY CASE BASIS.



**WINDSOR
UTILITIES
COMMISSION**

**MULTI WATER METER ARRANGEMENT MAX. 6 UNIT DEVELOPMENT
RESIDENTIAL, COMMERCIAL, INDUSTRIAL, OR INSTITUTIONAL**

DRAWN BY: B.J.O.	CHECKED BY: S.J.	APPROVED BY: C.M.	REVISION DATE: NOV. 2024	DWG. NO.: 50.09.04
---------------------	---------------------	----------------------	-----------------------------	------------------------------

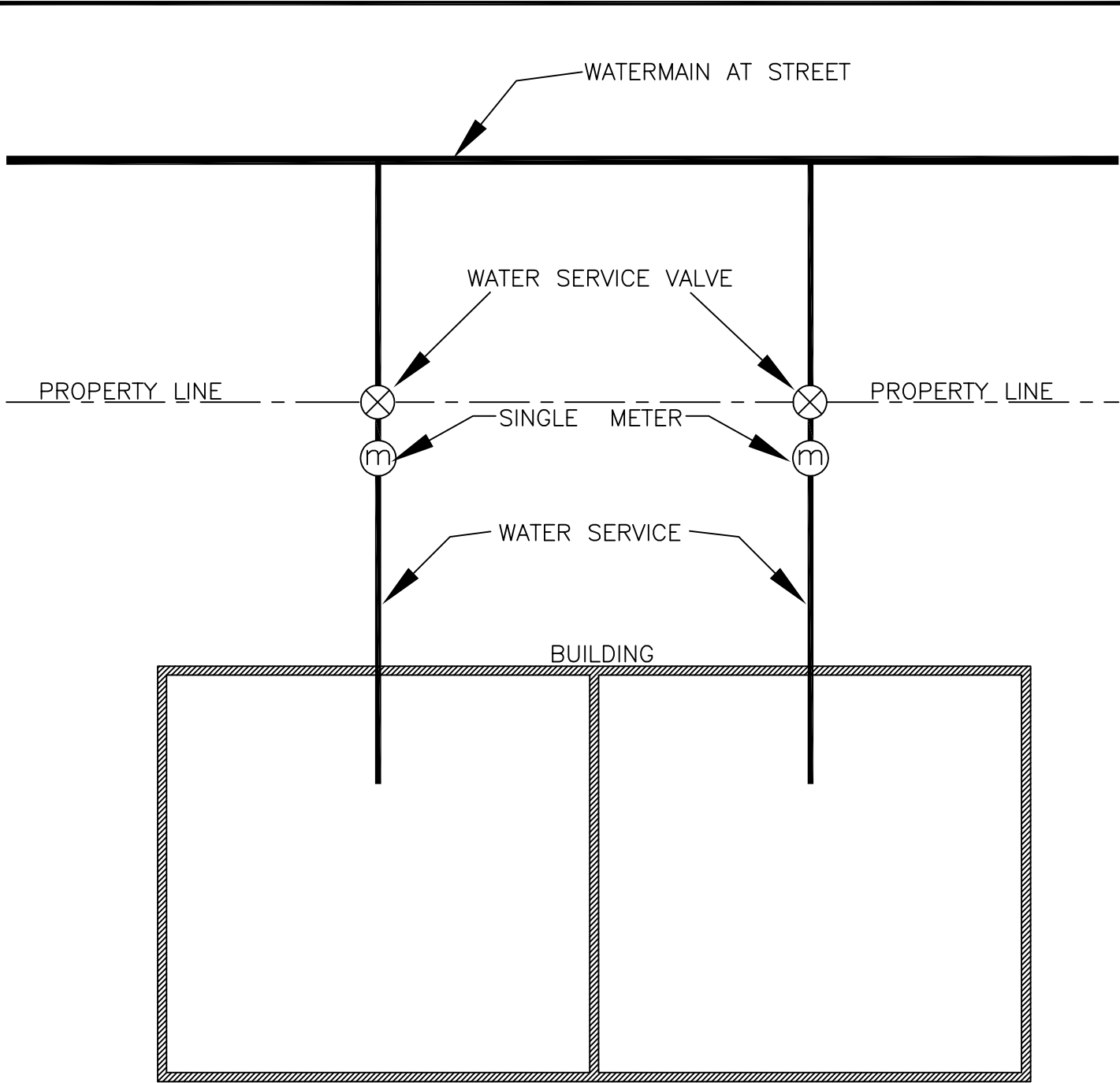

Ⓜ METER IN A PIT

NOTE 1: METERS SHALL BE IN PITS ONLY FOR ALL RESIDENTIAL PROPERTIES.

NOTE 2: METERING OPTIONS TO BE DECIDED BY WATER ENGINEERING ON A CASE BY CASE BASIS.

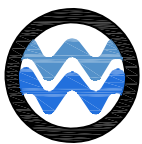

**WINDSOR
UTILITIES
COMMISSION**

**SINGLE WATER METER ARRANGEMENT FOR
SINGLE OR MULTI SINGLE RESIDENTIAL BUILDINGS**

DRAWN BY:
B.J.O.

CHECKED BY:
S.J.

APPROVED BY:
C.M.

REVISION DATE:
NOV. 2023

DWG. NO.:
50.09.05

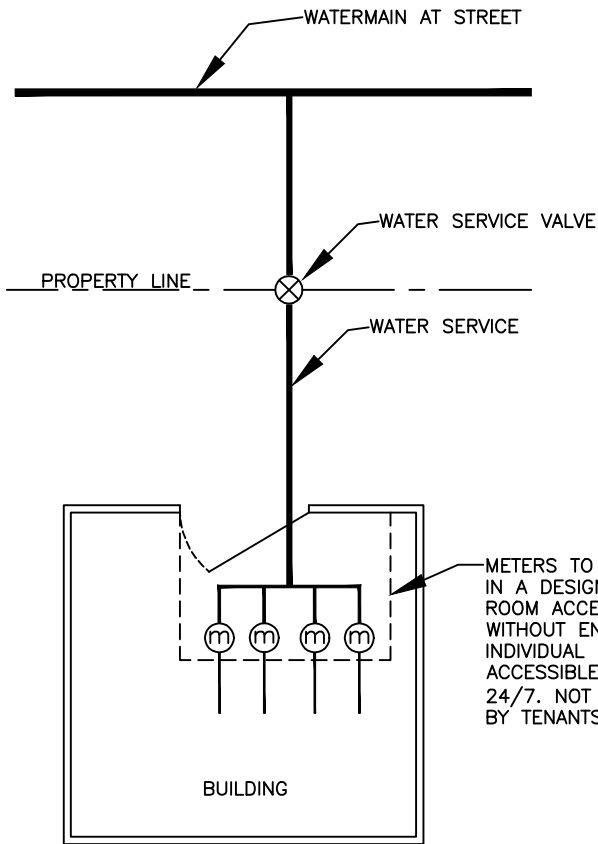

PLAN VIEW

METERS TO BE LOCATED IN A DESIGNATED METER ROOM ACCESSIBLE WITHOUT ENTERING INDIVIDUAL UNITS AND ACCESSIBLE BY W.U.C. 24/7. NOT ACCESSIBLE BY TENANTS.

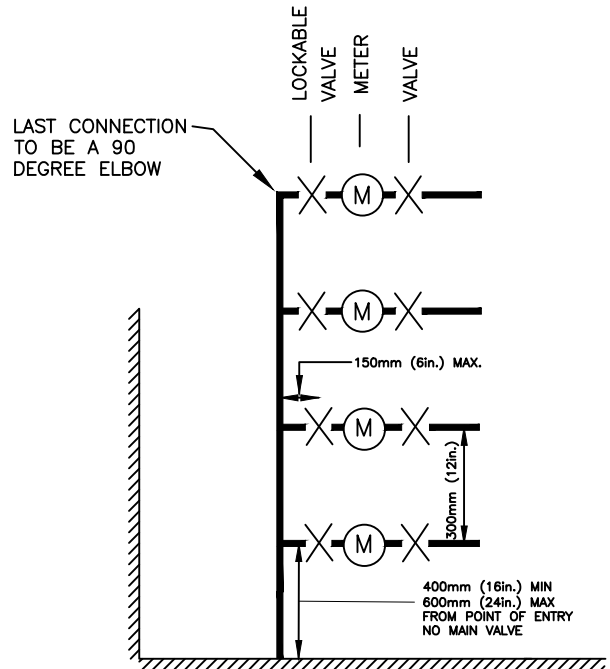

PROFILE VIEW

NOTE 1: FOR METERS TO BE INSTALLED INDOORS THERE NEEDS TO BE A DESIGNATED METER ROOM OR MECHANICAL ROOM WITHOUT ENTERING INDIVIDUAL UNITS AND ACCESSIBLE BY W.U.C. 24/7. NOT ACCESSIBLE BY TENANTS.

NOTE 2: METERING OPTIONS TO BE DECIDED BY WATER ENGINEERING ON A CASE BY CASE BASIS.

NOTE 3: WATER METERS TO BE INSTALLED HORIZONTALLY

NOTE 4: TOP METER AT MAXIMUM 5 FT IN HEIGHT



WINDSOR
UTILITIES
COMMISSION

MULTI WATER METER ARRANGEMENT WITH METERS IN METER ROOM (RESIDENTIAL MULTI-UNIT MINIMUM 4 METERS)

DRAWN BY: B.J.O.	CHECKED BY: S.J.	APPROVED BY: C.M.	REVISION DATE: NOV. 2024	DWG. NO.: 50.09.06
---------------------	---------------------	----------------------	-----------------------------	-----------------------

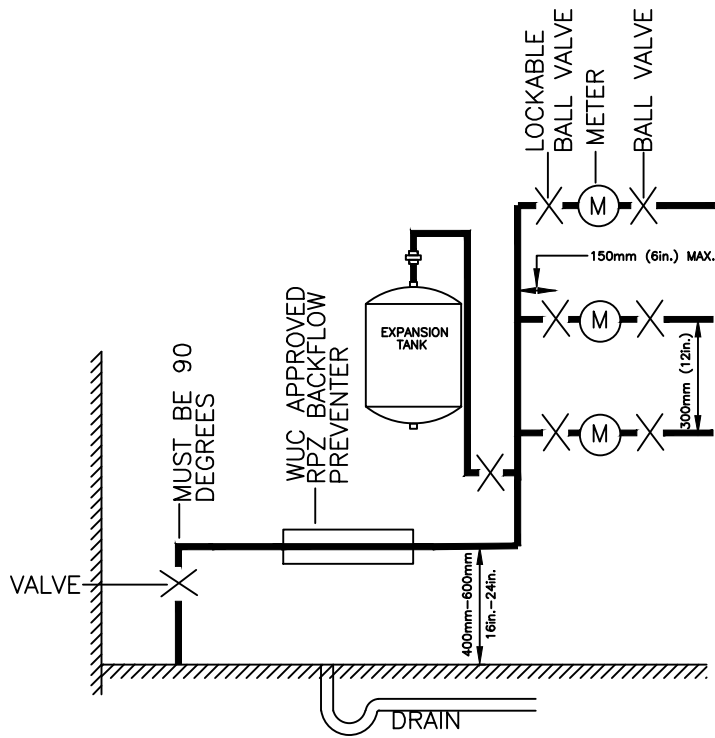

MULTIPLE METERS

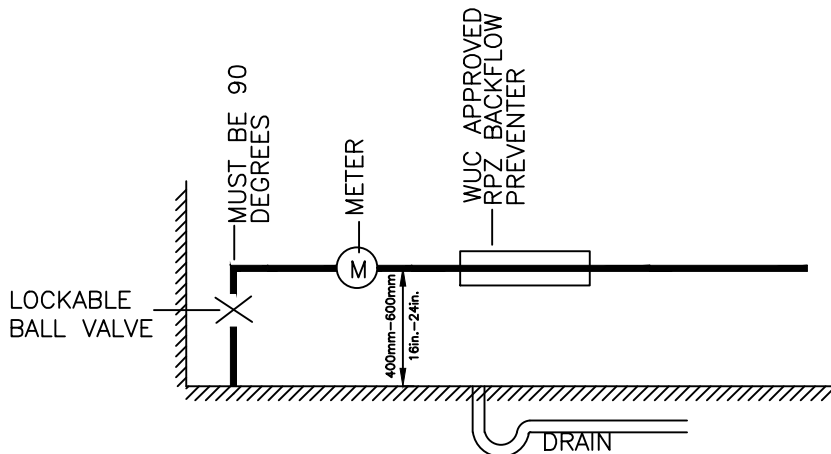

SINGLE METER

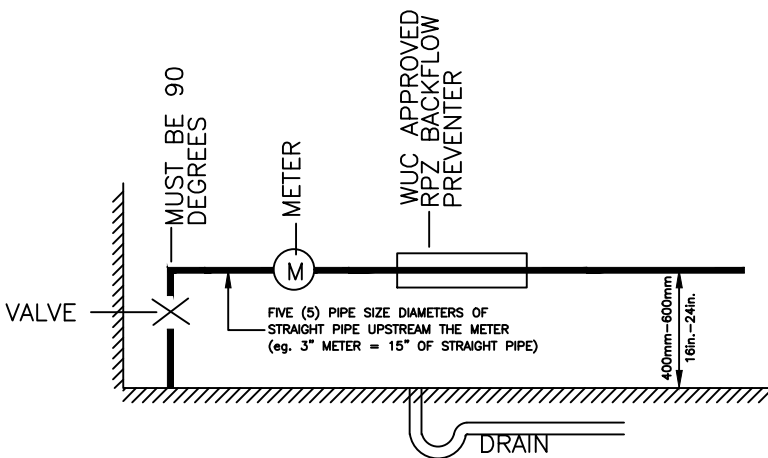

3" METER AND LARGER

NOTES:

1. PREMISE BACKFLOW PREVENTERS ON NEW INSTALLATIONS SHALL BE RP TYPE AND BE INSTALLED AS SHOWN.
2. FOR METERS TO BE INSTALLED INDOORS THERE NEEDS TO BE A DESIGNATED METER ROOM OR MECHANICAL ROOM WITH EXTERIOR ACCESS ONLY (EXCEPT FOR APARTMENT BUILDINGS) AND 24/7 ACCESS FOR W.U.C.
3. METERING OPTIONS TO BE DECIDED BY WATER ENGINEERING ON A CASE BY CASE BASIS.



**WINDSOR
UTILITIES
COMMISSION**

**METER AND BACKFLOW CONFIGURATION INSIDE FOR
COMMERCIAL, INSTITUTIONAL, AND APARTMENT BUILDINGS**

DRAWN BY:

B.J.O.

CHECKED BY:

S.J.

APPROVED BY:

C.M.

REVISION DATE:

NOV. 2024

DWG. NO.:

50.09.07

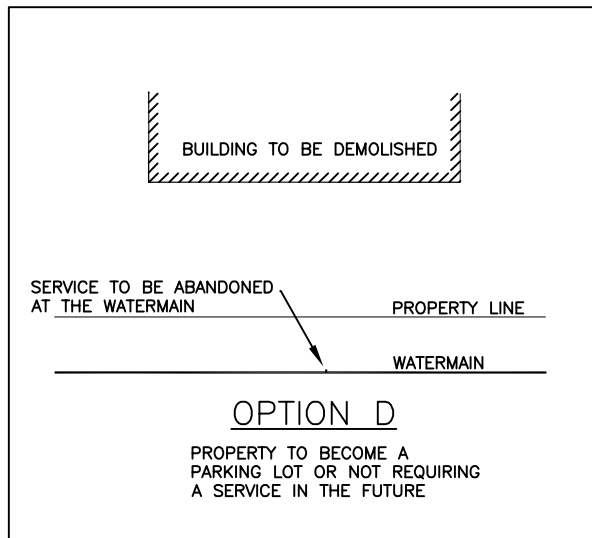
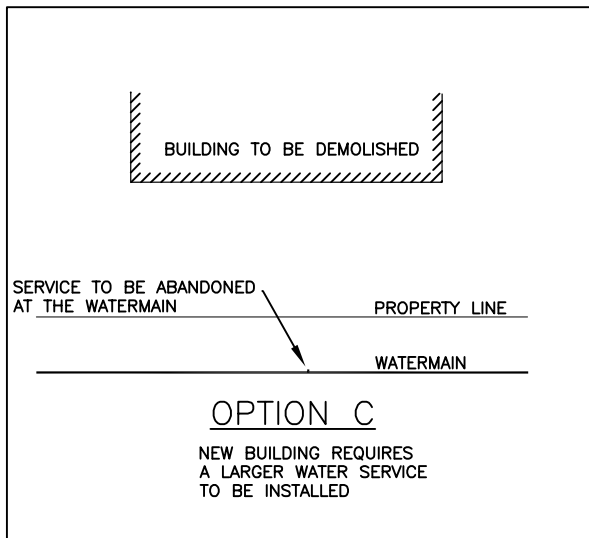
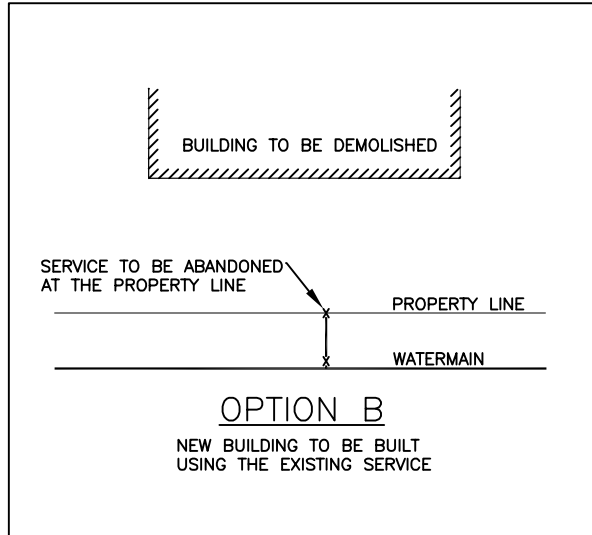
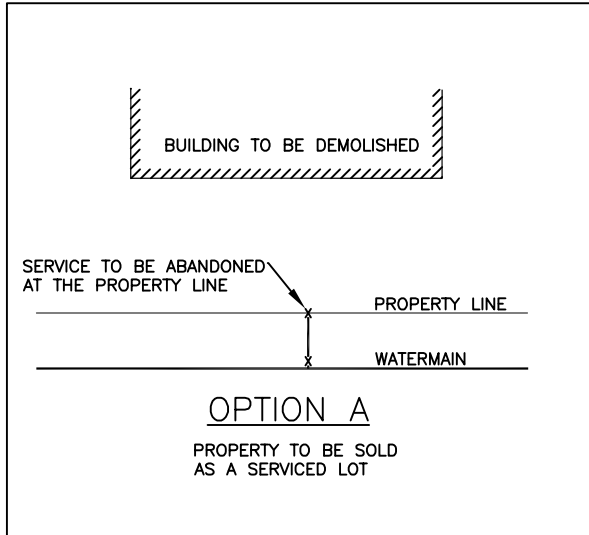

NOTE 1: ABANDONMENT WORK TO BE AT THE SOLE COST OF THE PROPERTY OWNER / DEVELOPER.

NOTE 2: ABANDONMENT PERMITS AND DEPOSITS ARE REQUIRED AND ARE TO BE TAKEN OUT WITH ENWIN / WUC.

NOTE 3: ABANDONMENT OPTIONS TO BE DECIDED BY WATER ENGINEERING ON A CASE BY CASE BASIS.

NOTE 4: ABANDONMENTS ARE TO BE WITNESSED BY ENWIN / WUC PERSONNEL ONLY.

NOTE 5: ONCE THE ABANDONMENT IS COMPLETED TO THE SATISFACTION OF THE ENWIN / WUC PERSONNEL THE DEPOSIT CAN BE REFUNDED.



ABANDONMENT OPTIONS FOR RESIDENTIAL PROPERTIES

DRAWN BY: B.J.O.	CHECKED BY: S.J.	APPROVED BY: C.M.	REVISION DATE: NOV. 2023	DWG. NO.: 50.10.01A
---------------------	---------------------	----------------------	-----------------------------	-------------------------------

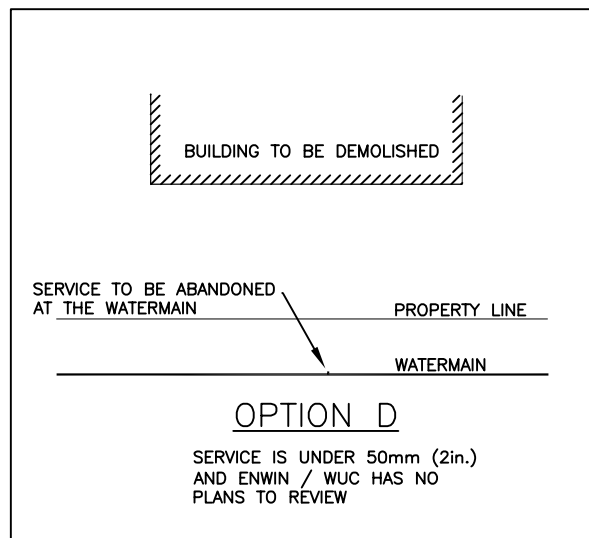
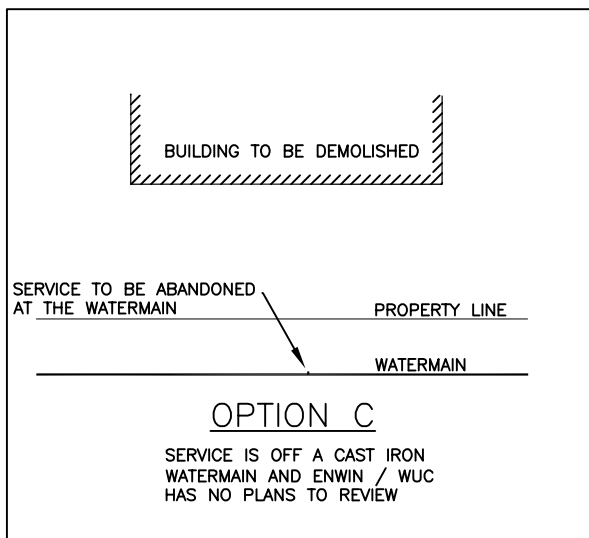
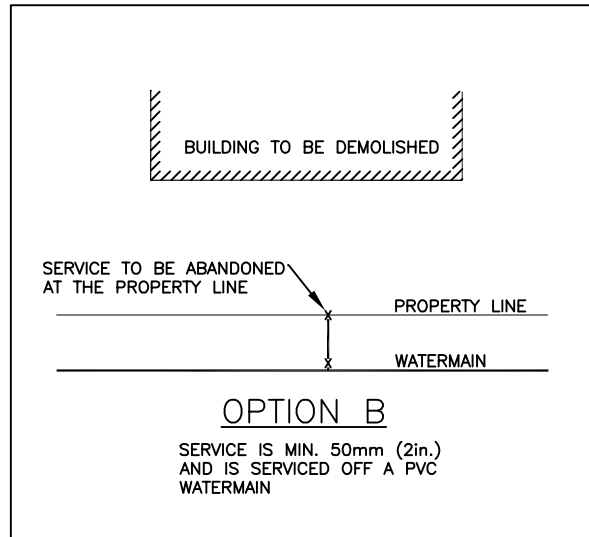
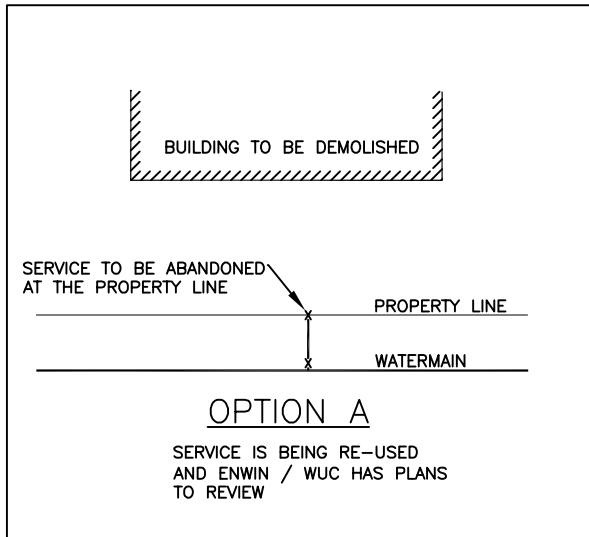

NOTE 1: ABANDONMENT WORK TO BE AT THE SOLE COST OF THE PROPERTY OWNER / DEVELOPER.

NOTE 2: ABANDONMENT PERMITS AND DEPOSITS ARE REQUIRED AND ARE TO BE TAKEN OUT WITH ENWIN / WUC.

NOTE 3: ABANDONMENT OPTIONS TO BE DECIDED BY WATER ENGINEERING ON A CASE BY CASE BASIS.

NOTE 4: ABANDONMENTS ARE TO BE WITNESSED BY ENWIN / WUC PERSONNEL ONLY.

NOTE 5: ONCE THE ABANDONMENT IS COMPLETED TO THE SATISFACTION OF THE ENWIN / WUC PERSONNEL THE DEPOSIT CAN BE REFUNDED.

NOTE 6: PLANS NEED TO LABEL THE EXISTING SERVICE IS BEING RE-USED FOR OPTION 'A'.



**ABANDONMENT OPTIONS FOR INDUSTRIAL,
COMMERCIAL, AND INSTITUTIONAL PROPERTIES**

DRAWN BY: B.J.O.	CHECKED BY: S.J.	APPROVED BY: C.M.	REVISION DATE: NOV. 2023	DWG. NO.: 50.10.01B
---------------------	---------------------	----------------------	-----------------------------	-------------------------------

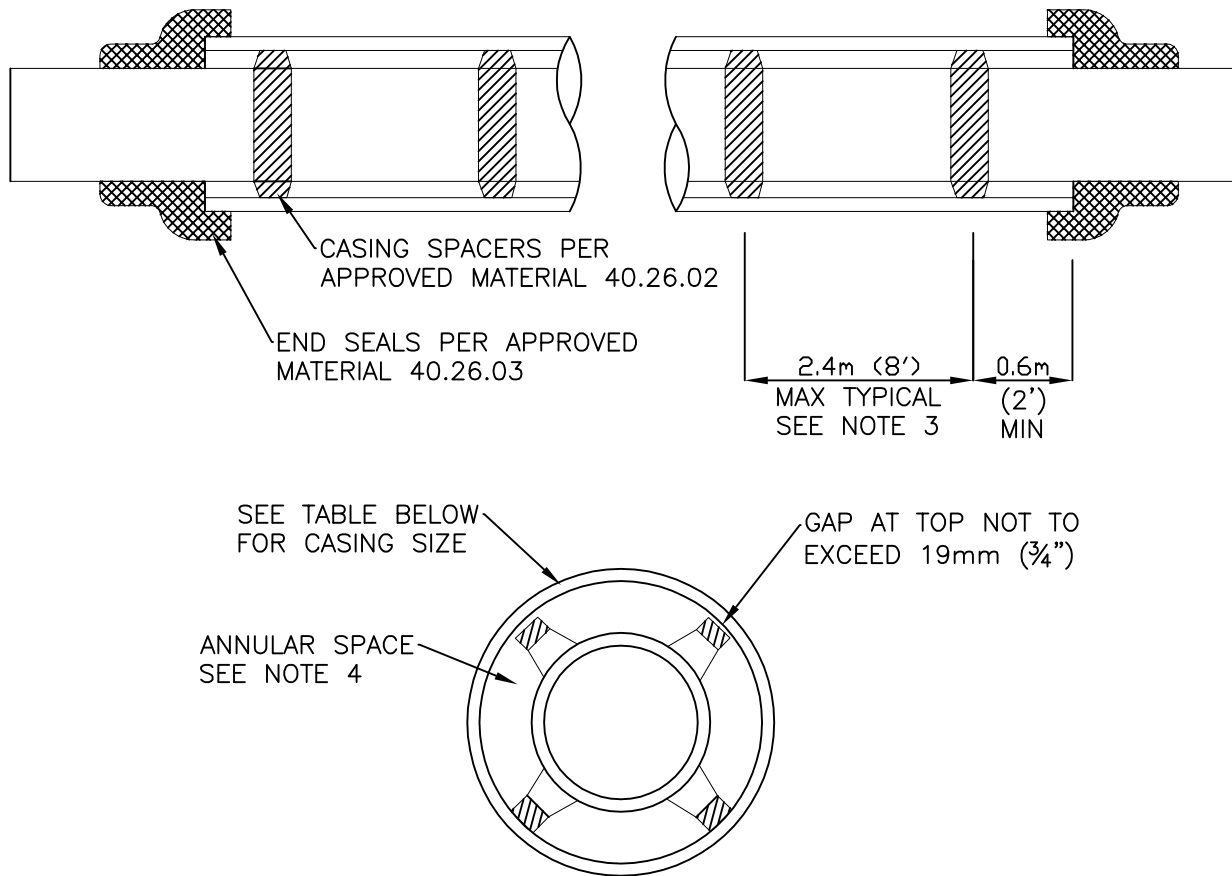

NOTES:

1. REFER TO APPROVED MATERIAL LISTING FOR ALL MATERIALS TO BE USED.
2. ANODES TO BE INSTALLED ON ALL CASINGS.
3. INSTALL A MINIMUM OF 3 SPACERS PER 6m (20') PIPE SECTION EQUALLY SPACED.
4. THE ANNULAR SPACE BETWEEN THE PIPE AND CASING SHALL NOT BE FILLED WITH ANY MATERIAL.
5. THE WATERMAIN SHALL BE RESTRAINED LATERALLY FOR THE ENTIRE LENGTH OF THE CASING.
6. TRACER WIRE SHALL BE INSTALLED INSIDE AND ALONG THE FULL LENGTH OF THE CASING.

PIPE SIZE	MIN. CASING SIZE	MIN. WALL THICKNESS
150mm (6")	350mm (14")	9.53mm (3/8")
200mm (8")	400mm (16")	9.53mm (3/8")
300mm (12")	500mm (20")	9.53mm (3/8")
400mm (16")	750mm (30")	12.7mm (1/2")
500mm (20")	900mm (36")	12.7mm (1/2")
600mm (24")	1050mm (42")	12.7mm (1/2")



PIPE CASING INSTALLATION

DRAWN BY:	CHECKED BY:	APPROVED BY:	REVISION DATE:	DWG. NO.:
	B.J.O.	N.P.	MARCH/2015	50.11.01

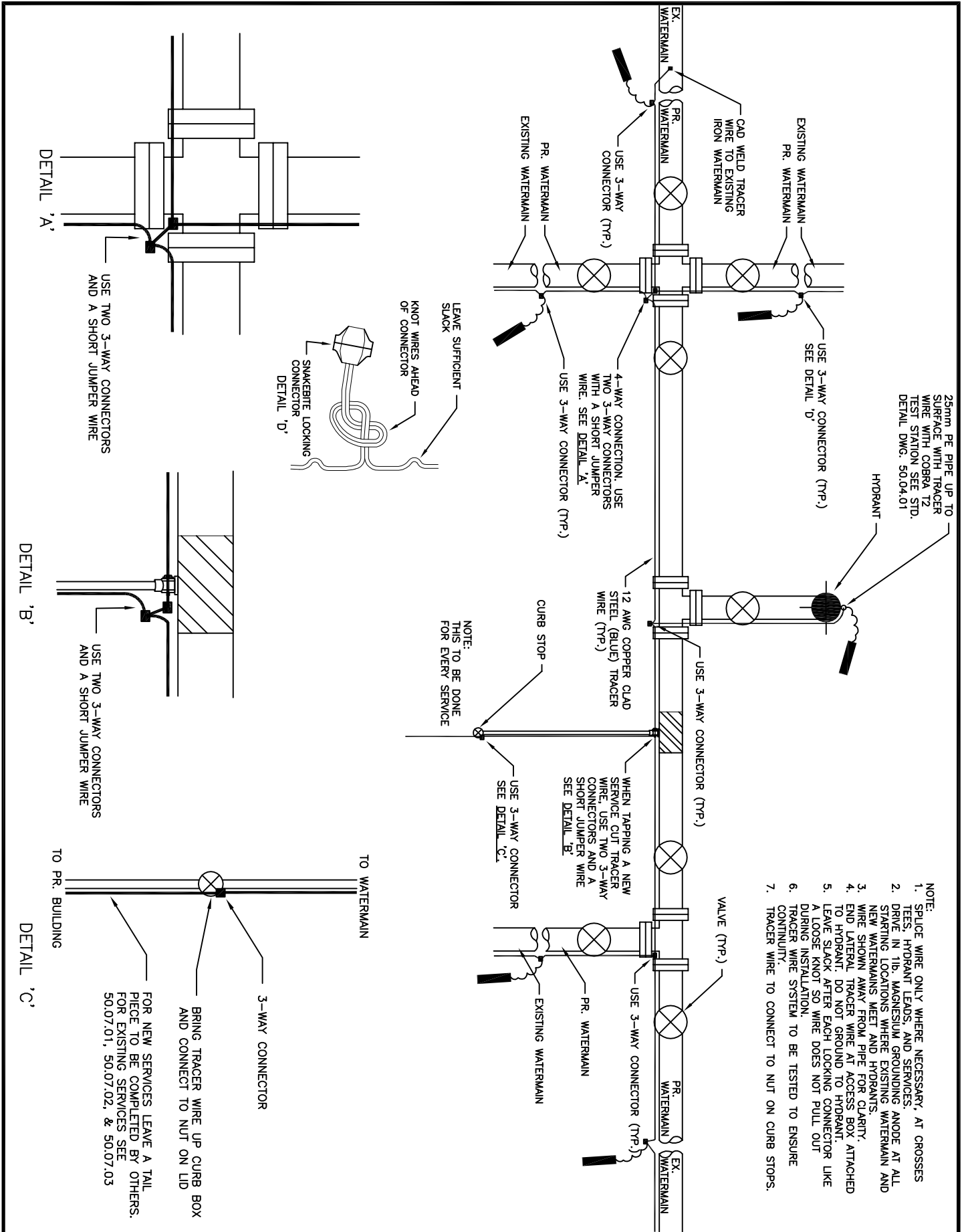

TRACER WIRE INSTALLATION



**WINDSOR
UTILITIES
COMMISSION**

DRAWN BY:

CHECKED BY:

APPROVED BY:

REVISION DATE:

DWG. NO.:

B.J.O.

N.P.

OCT. / 2016

50.12.01

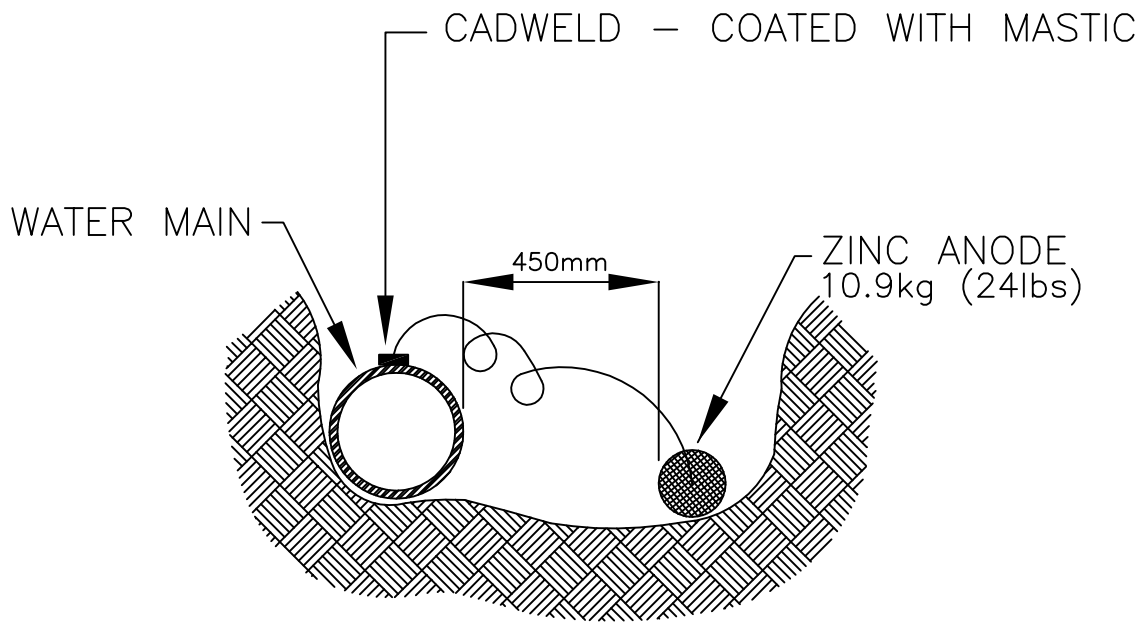

ZINC ANODE

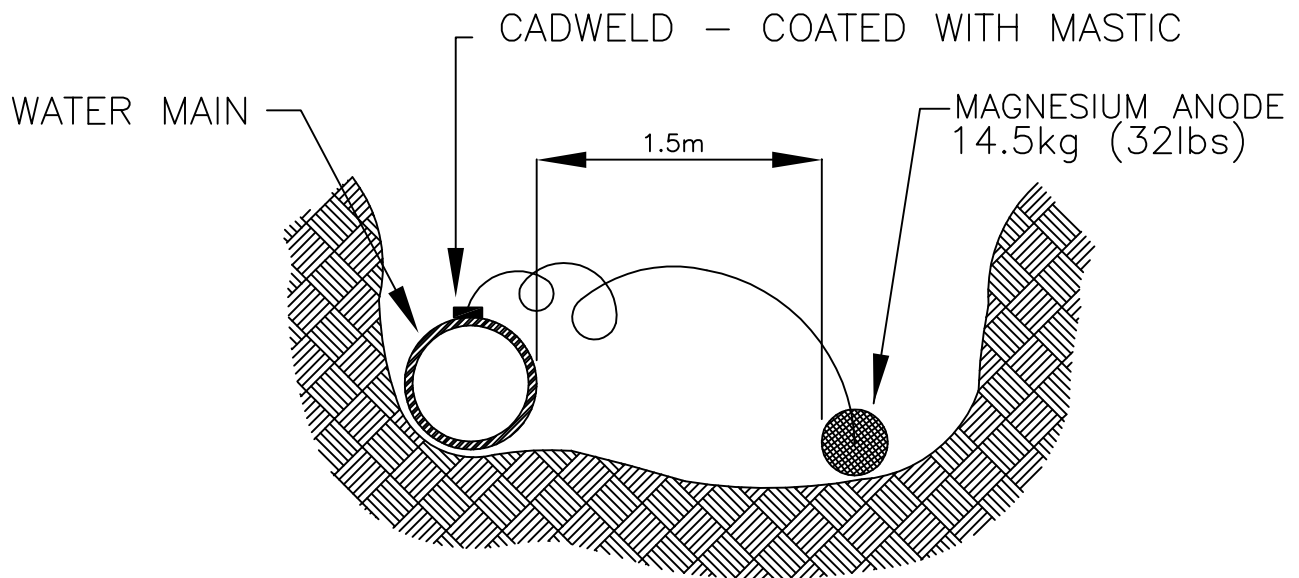

MAGNESIUM ANODE

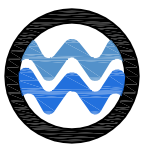

WINDSOR
UTILITIES
COMMISSION

MAGNESIUM AND ZINC
ANODE INSTALLATION

DRAWN BY:

CHECKED BY:

APPROVED BY:

REVISION DATE:

DWG. NO.:

V.S.

N.P.

MARCH/2015

50.13.01

BOULEVARD AREA

PAVEMENT AREA

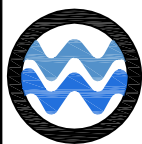
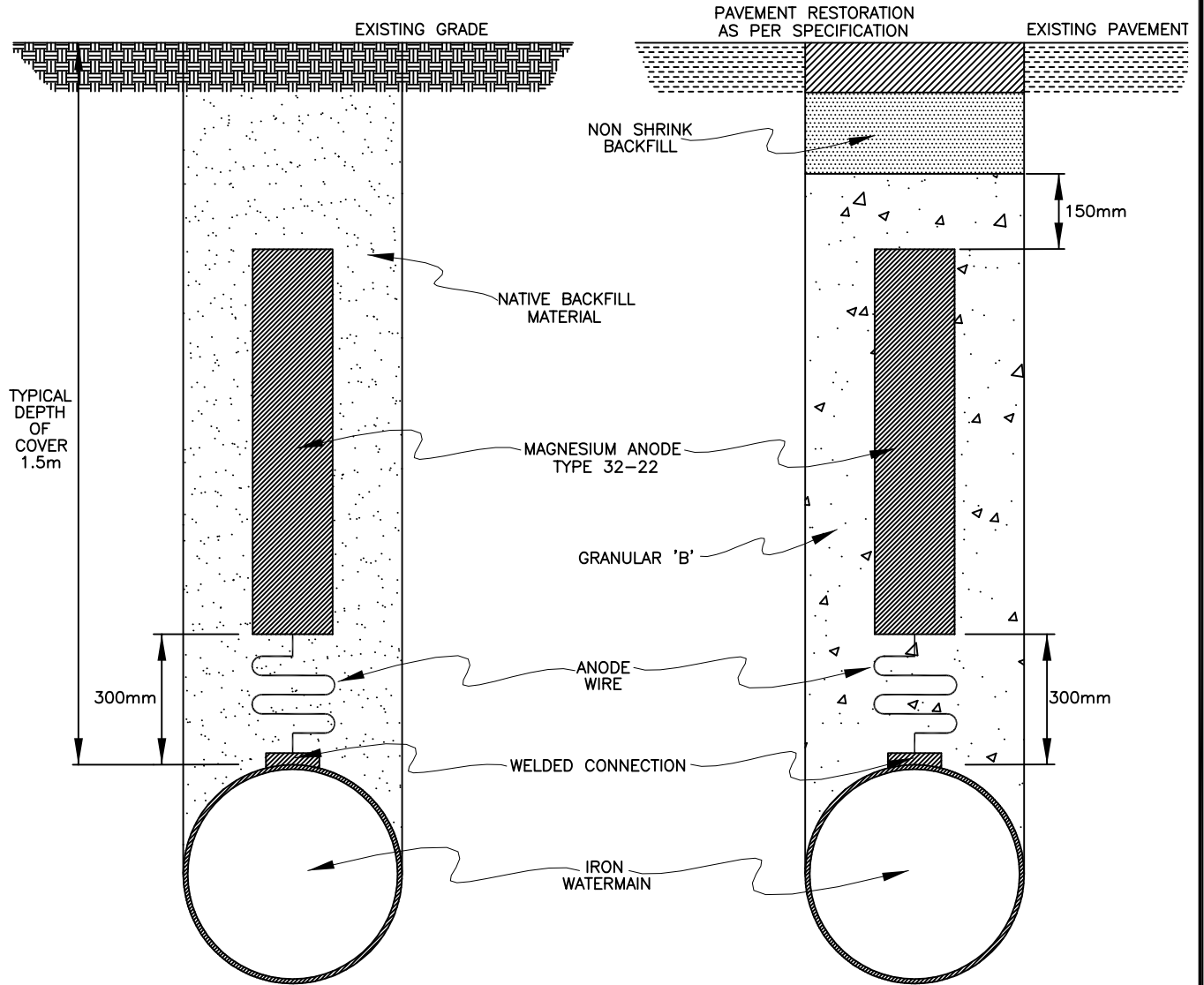

WINDSOR
UTILITIES
COMMISSION

ANODE INSTALLATION IN AUGURED HOLE

DRAWN BY:

CHECKED BY:

APPROVED BY:

REVISION DATE:

DWG. NO.:

V.S.

N.P.

MARCH/2015

50.13.02

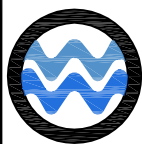
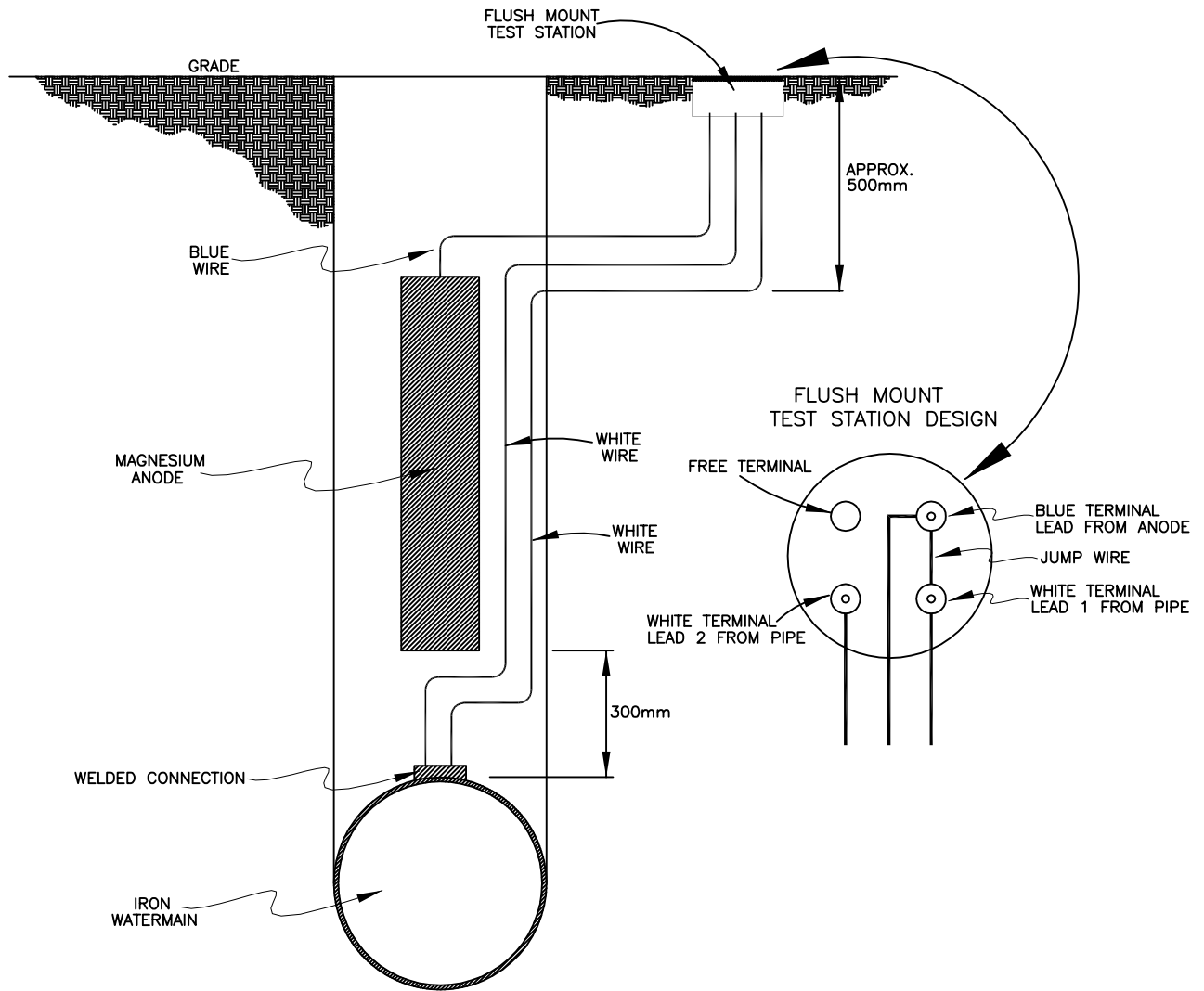

WINDSOR
UTILITIES
COMMISSION

TEST STATION INSTALLATION

DRAWN BY:

CHECKED BY:

V.S.

APPROVED BY:

N.P.

REVISION DATE:

MARCH/2015

DWG. NO.:

50.13.03

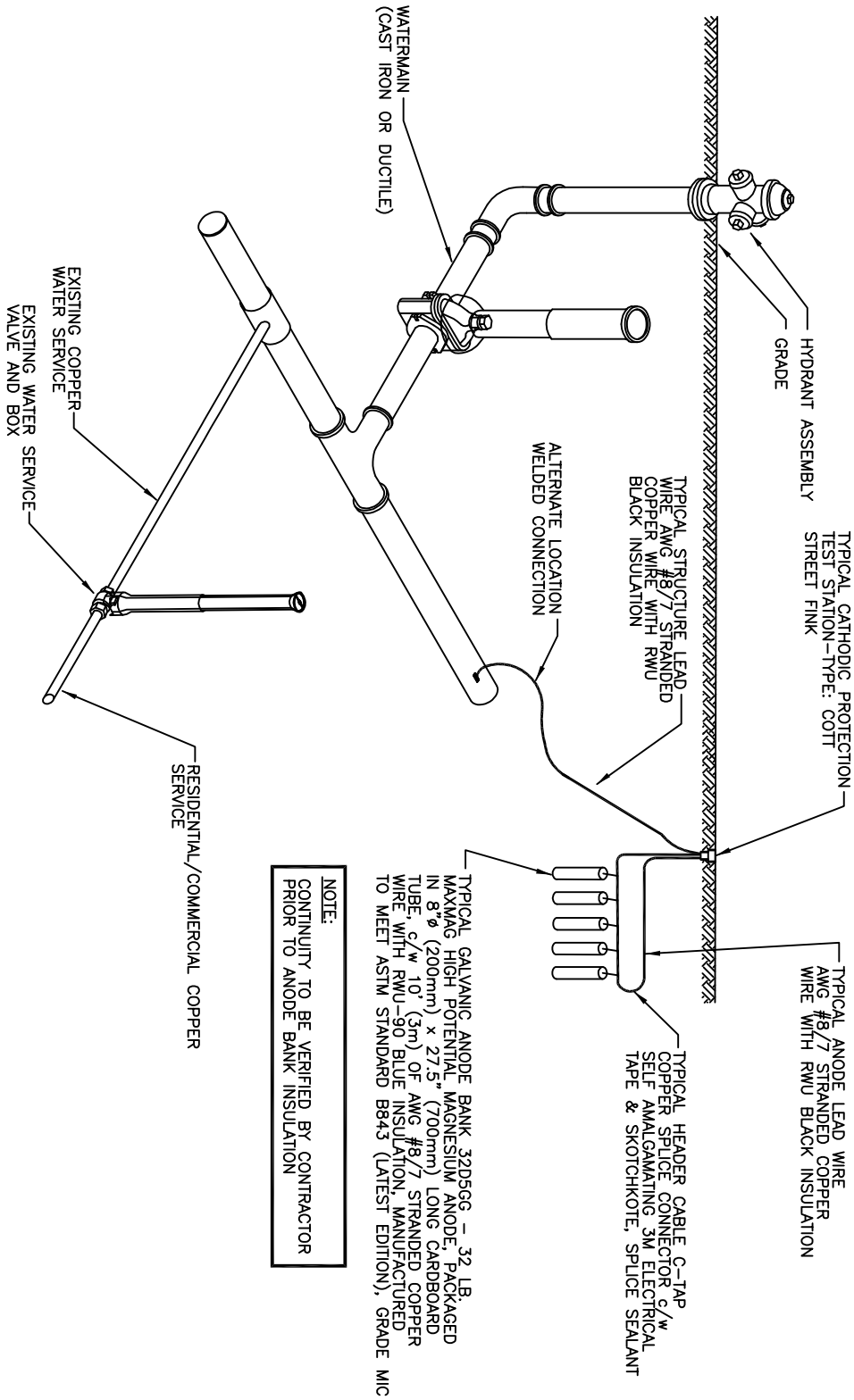

NOTE:
 CONTINUITY TO BE VERIFIED BY CONTRACTOR
 PRIOR TO ANODE BANK INSULATION

TYPICAL GALVANIC ANODES (BANK OF FIVE)

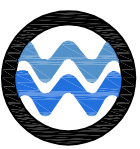

**WINDSOR
 UTILITIES
 COMMISSION**

DRAWN BY:	CHECKED BY:	APPROVED BY:	REVISION DATE:	DWG. NO.:
	V.S.	N.P.	AUGUST 2015	50.13.04

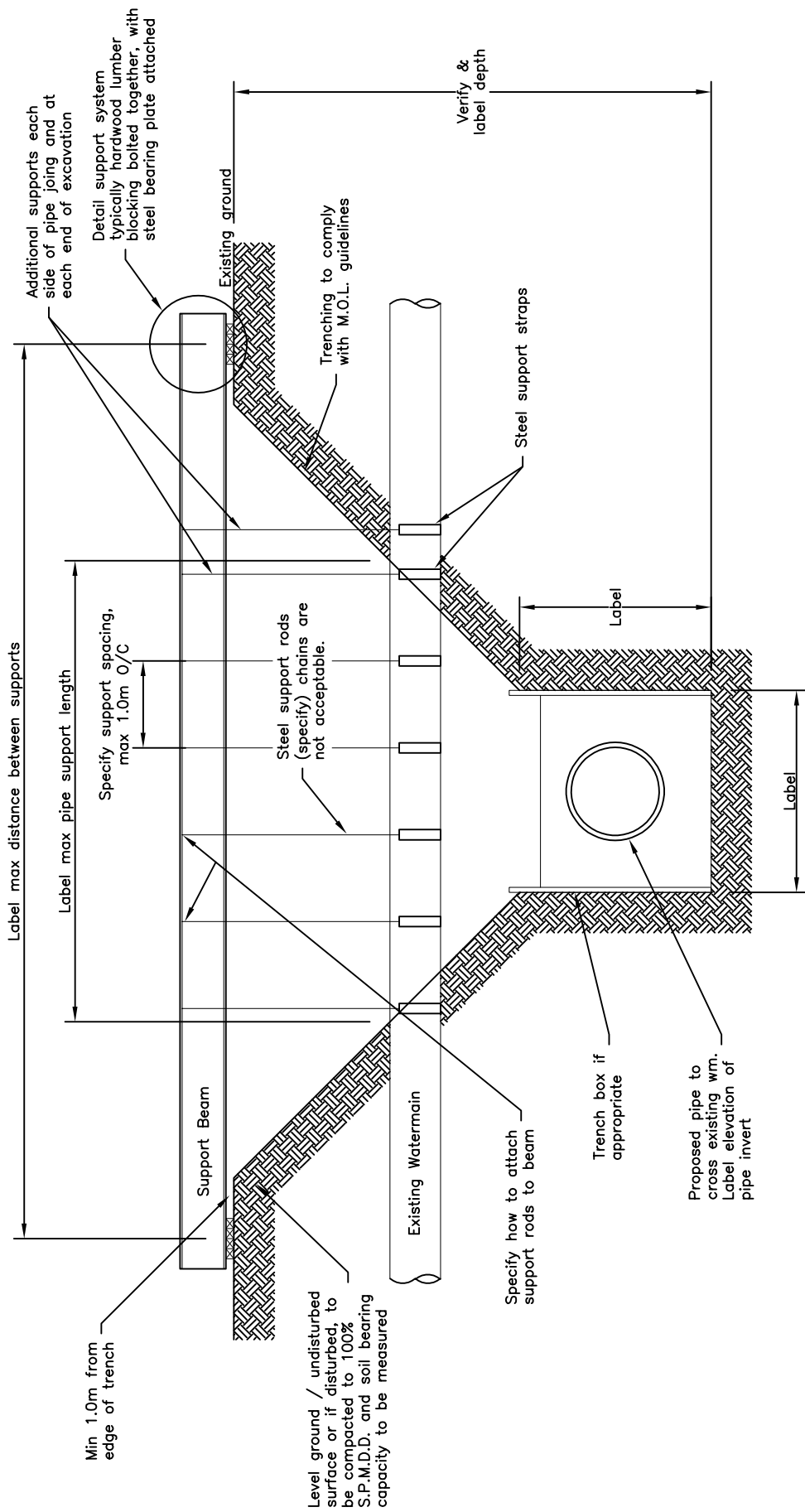

NOTES:
 THIS DRAWING IS FOR ILLUSTRATIVE PURPOSES ONLY AND IS MEANT TO SHOW A GENERAL EXAMPLE OF A SUPPORT DESIGN. THE ACTUAL DESIGN IS TO BE AT THE DISCRETION OF THE DESIGN ENGINEER IN ACCORDANCE WITH THE REQUIREMENTS SET OUT IN 50.14.01C.



SUPPORT CROSS SECTION EXAMPLE

DRAWN BY: M.L.	CHECKED BY: B.O.	APPROVED BY: C.M.	REVISION DATE: NOV / 2020	DWG. NO.: 50.14.01A
-------------------	---------------------	----------------------	------------------------------	-------------------------------

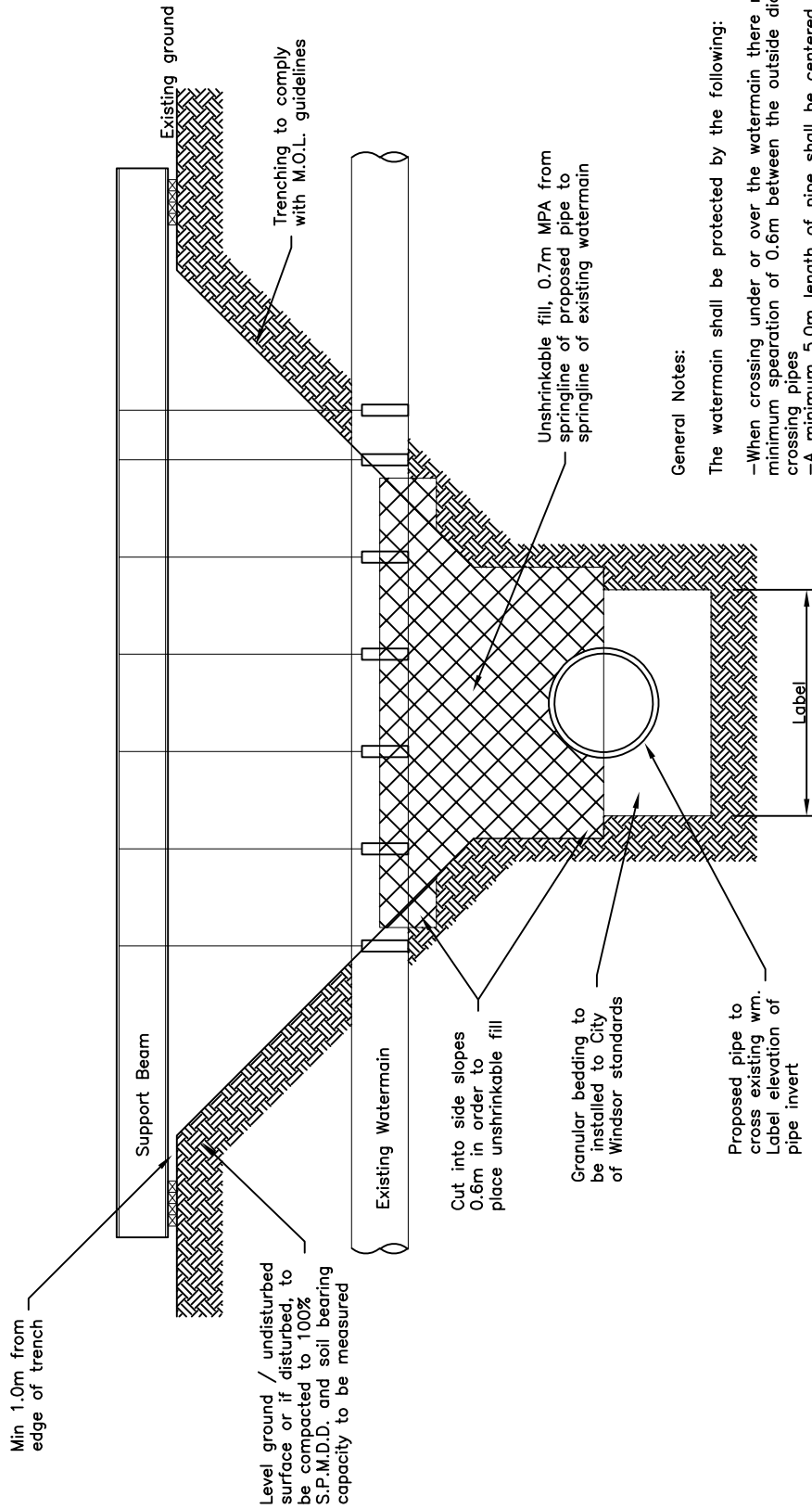

General Notes:

The watermain shall be protected by the following:

- When crossing under or over the watermain there must be a minimum separation of 0.6m between the outside diameters of the crossing pipes
 - A minimum 5.0m length of pipe shall be centered at the point of crossing so that the watermain joints will be equidistant and as far as possible from the sewer or PDC. Crossing must be absolute minimum 2.0m from watermain joint.
 - All construction methods including excavation and backfill compaction within 0.6m of existing watermain shall be done by hand.
- It should be noted that the support structure is to remain in place until the watermain is fully supported by the reinstated bedding (i.e. until 0.7 MPA unshrinkable fill is cured, provide bond break).

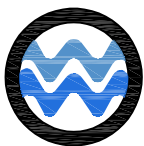

**WINDSOR
UTILITIES
COMMISSION**

TYPICAL REINSTATEMENT / BEDDING DETAIL CROSS SECTION

DRAWN BY:
M.L.

CHECKED BY:
B.O.

APPROVED BY:
C.M.

REVISION DATE:
NOV / 2020

DWG. NO.:
50.14.01B

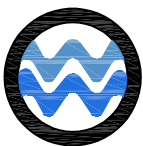

**GENERAL SUBMISSION AND DESIGN REQUIREMENTS FOR
WATERMAIN SUPPORT AND BEDDING / REINSTATEMENT**

DRAWN BY:
M.L.

CHECKED BY:
B.O.

APPROVED BY:
C.M.

REVISION DATE:
NOV / 2020

DWG. NO.:
50.14.01C

SUPPORT DETAIL REQUIREMENTS

Submission and Design Requirements

When crossing below an existing watermain (400mm diameter and greater) using open cut construction, the following must be provided to the Windsor Utilities Commission Water Engineering Division for review/approval a minimum of two (2) weeks prior to the proposed work taking place:

1) A utility support system drawing stamped by a Professional Engineer, including the following: (See 50.14.01A for example drawing)

- A) Complete plan and cross-section drawings indicating support system including all appropriate dimensions and details.
 - B) Provide all structural calculations for support systems including load and deflection information for proposed beam. Provide details to confirm adequacy of support mechanism proposed to transfer loading of supported utility to support beam.
 - C) Provide calculations for loading transferred to the end support of the beam structure and confirm adequate soil bearing capacity for the system designed for beam supports.
 - D) Identify procedure for transferring load of structure to be supported to the support beam.
- 2) Contractor's work plan. The work plan shall include the following;
- A) Identification of major activities to be carried out in association with the utility crossing.
 - B) A schedule of these works.
 - C) Monitoring of support system for deflection.

Under no circumstances will the work be allowed to proceed under adverse weather conditions.

The work may not proceed until all of the above are received and approved. Please note that traffic control plans affecting the City of Windsor right-of-way, if required, are to be submitted for approval separately to the City of Windsor. At all times, all requirements of the Occupational Health & Safety Act must be met.

BEDDING/REINSTATEMENT DETAIL REQUIREMENTS

Submission and Design Requirements

When crossing below an existing watermain (400mm diameter and greater) using open cut construction, the following must be provided to the Windsor Utilities Commission Water Engineering Division for review/approval a minimum of two (2) weeks prior to the proposed work taking place:

1) A drawing must be submitted indicating bedding/reinstatement which shall include the following: (See 50.14.01B for typical drawing)

- A) Cross-section drawing(s) including all appropriate dimensions and details.
 - B) If appropriate, identify insulation to be installed.
 - C) To prevent settlement of watermain, install 0.7MPa unshrinkable fill with bond breaker (ie. 6mil poly) to a minimum 600mm below watermain up to the centerline OR obtain recommendations regarding watermain bedding from the watermain pipe manufacturer, if any of the following apply;
 - i) There is less than 600mm separation between the utilities crossing each other,
 - OR
 - ii) Either structure is greater than 1000mm in diameter,
 - OR
 - iii) Insulation is being placed between the utilities.
- 2) Contractor's work plan. The work plan shall include the following;

- A) Identification of major activities to be carried out in association with the utility crossing.
- B) A schedule of these works.

Under no circumstances will the work be allowed to proceed under adverse weather conditions.

The work may not proceed until all of the above are received and approved. Please note that traffic control plans affecting the City of Windsor right-of-way, if required, are to be submitted for approval separately to the City of Windsor. At all times, all requirements of the Occupational Health & Safety Act must be met.

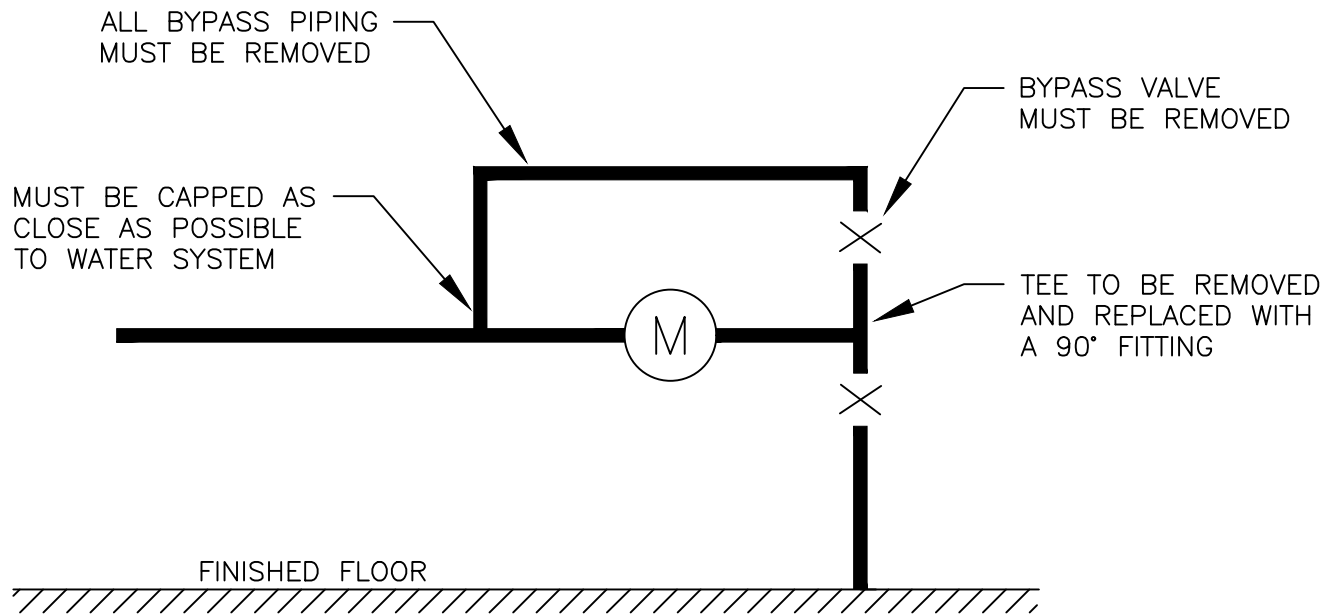

METER MUST BE INSTALLED HORIZONTALLY AND METER REGISTER FACING UPRIGHT.

METER HEIGHT FROM FINISHED FLOOR SHOULD BE NO MORE THAN 24" FROM THE POINT OF ENTRY.

ALL BYPASSES MUST BE REMOVED.



BYPASS REMOVAL

DRAWN BY:
M.L.

CHECKED BY:
J.H.

APPROVED BY:

REVISION DATE:

DWG. NO.:
50.15.01

MUST BE A 90° ANGLE. NO
TEES OR BRANCHES UPSTREAM
OF THE WATER METER.

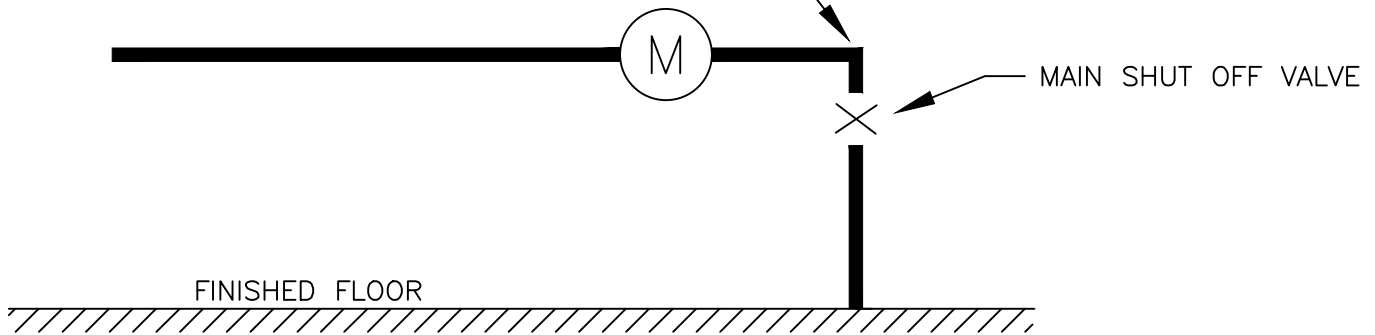

METER MUST BE INSTALLED HORIZONTALLY AND METER REGISTER FACING UPRIGHT.

METER HEIGHT FROM FINISHED FLOOR SHOULD BE NO MORE THAN 24" FROM THE POINT OF ENTRY.

ALL BYPASSES MUST BE REMOVED. (SEE 50.15.01)

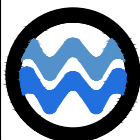

WINDSOR
UTILITIES
COMMISSION

SINGLE METER INSTALLATION OR DOWNSIZING (1.5" TO 2")

DRAWN BY:
M.L.

CHECKED BY:
J.H.

APPROVED BY:

REVISION DATE:

DWG. NO.:
50.15.02